

Thermocouples Straight Design per DIN EN 50 446 Model Series TC80, for High Temperature Measurement

WIKA Data Sheet TE 65.80

Applications

- Blast furnaces, cowper stoves
- Annealing and heat treatment processes
- Refuse, biomass, hazardous waste incineration
- Industrial heating installations, heat generation, power engineering, reactors
- Glass, porcelain, ceramics industry, cement and brick production

Special Features

- Application ranges up to max. +1600 °C (DIN EN 50 446)
- Thermowell made of heat-resistant steel or ceramic, also with ceramic inner tube
- Support tube of carbon steel
- Gastight process connection
- Coating (optional)

Description

Model TC80 series thermocouples were developed to measure extremely high temperatures. These high-temperature thermocouples comply with DIN EN 50 446. The thermoelectric wires of the thermocouple fitted within the thermowell are contained either in the capillary holes of a ceramic insulating tube or in the capillary holes of an insulating rod. A thermowell made from high-temperature alloy metal or high-temperature ceramic, with or without an additional inner tube, protects the thermocouple from the process medium as well as mechanical and chemical damage.

A wide selection of process connections, e.g. stop flanges, threaded collars and solid welded flanges, permit direct mounting to the process. For particularly critical applications there are designs with inert gas or compressed air purging or with pressure tight sealing. Of course extremely robust thermowell assemblies can also be used.



Thermocouples Straight Design, Model Series TC80

Optionally a transmitter can be fitted. One of the advantages of a built-in transmitter is the increased reliability of the signal transmission. Between the transmitter and the control room, more-economical copper cable can be used rather than specific thermocouple or compensating cable. A cold junction is integrated in all WIKA transmitters.

Sensor

Sensor type

Type	Thermocouple	Recommended max. operating temperature	
		DIN EN 60 584-2	ISA (ANSI) MC96.1-1982
K (NiCr-Ni)	non-precious	1200 °C	1200 °C
N (NiCrSi-NiSi)	non-precious	1200 °C	1200 °C
J (Fe-CuNi)	non-precious	750 °C	760 °C
S (Pt10% Rh-Pt)	precious metal	1600 °C	1480 °C
R (Pt13% Rh-Pt)	precious metal	1600 °C	1480 °C
B (Pt30% Rh-Pt6% Rh)	precious metal	1700 °C	1700 °C

The application range of these thermometers is limited by the permissible maximum temperature of the thermocouple as well as the max. permissible temperature of the thermowell material.

Listed thermocouples are available both as single and dual. The measuring point (hot junction) of the probe is supplied ungrounded.

Sensor limiting error

A cold junction temperature of 0 °C is taken as the basis for the definition of the sensor limiting error of thermocouples.

Type K and N

Class	Temperature range	Limiting error
DIN EN 60 584 part 2		
1	-40 °C ... +375 °C	± 1.5 °C
1	+375 °C ... +1000 °C	± 0.0040 · t ¹⁾
2	-40 °C ... +333 °C	± 2.5 °C
2	+333 °C ... +1200 °C	± 0.0075 · t ¹⁾
ISA (ANSI) MC96.1-1982		
Standard	0 °C ... +1260 °C	± 2.2 °C or ²⁾ ± 0.75 %
Special	0 °C ... +1260 °C	± 1.1 °C or ²⁾ ± 0.4 %

Limiting error with selected temperatures in °C for Type K and Type N thermocouples

Temperature (ITS 90) °C	Limiting error DIN EN 60 584 Part 2	
	Class 1 °C	Class 2 °C
350	± 1.5	± 2.625
500	± 2.0	± 3.75
600	± 2.4	± 4.50
700	± 2.8	± 5.25
800	± 3.2	± 6.00
900	± 3.6	± 6.75
1000	± 4.0	± 7.50
1100	-	± 8.25
1200	-	± 9.00

Type J

Class	Temperature range	Limiting error
DIN EN 60 584 part 2		
1	-40 °C ... +375 °C	± 1.5 °C
1	+375 °C ... +750 °C	± 0.0040 · t ¹⁾
2	-40 °C ... +333 °C	± 2.5 °C
2	+333 °C ... +750 °C	± 0.0075 · t ¹⁾
ISA (ANSI) MC96.1-1982		
Standard	0 °C ... +760 °C	± 2.2 °C or ²⁾ ± 0.75 %
Special	0 °C ... +760 °C	± 1.1 °C or ²⁾ ± 0.4 %

Limiting error with selected temperatures in °C for Type J thermocouples

Temperature (ITS 90) °C	Limiting error DIN EN 60 584 Part 2	
	Class 1 °C	Class 2 °C
350	± 1.5	± 2.625
500	± 2.0	± 3.75
600	± 2.4	± 4.50
700	± 2.8	± 5.25

Type S and R

Class	Temperature range	Limiting error
DIN EN 60 584 part 2		
1	0 °C ... +1100 °C	± 1.0 °C
1	+1100 °C ... +1600 °C	± (1 + 0.003 · (t - 1100)) ¹⁾
2	0 °C ... +600 °C	± 1.5 °C
2	+600 °C ... +1600 °C	± 0.0025 · t ¹⁾
ISA (ANSI) MC96.1-1982		
Standard	0 °C ... +1480 °C	± 1.5 °C or ²⁾ ± 0.25 %
Special	0 °C ... +1480 °C	± 0.6 °C or ²⁾ ± 0.1 %

1) |t| is the value of the temperature in °C without consideration of the sign.
2) Whichever is larger.

Limiting error with selected temperatures in °C for Type S and Type R thermocouples

Temperature (ITS 90) °C	Limiting error DIN EN 60 584 Part 2	
	Class 1 °C	Class 2 °C
350	± 1.0	± 1.5
500	± 1.0	± 1.5
600	± 1.0	± 1.5
700	± 1.0	± 1.8
800	± 1.0	± 2.0
900	± 1.0	± 2.3
1000	± 1.0	± 2.5
1100	± 1.0	± 2.8
1200	± 1.3	± 3.0
1300	± 1.6	± 3.3
1400	± 1.9	± 3.5
1500	± 2.2	± 3.8
1600	± 2.5	± 4.0

Type B

Class	Temperature range	Limiting error
DIN EN 60 584 part 2		
2	+600 °C ... +1700 °C	$\pm 0.0025 \cdot t $ ¹⁾
3	+600 °C ... +800 °C	± 4.0 °C
3	+800 °C ... +1700 °C	$\pm 0.005 \cdot t $ ¹⁾
ISA (ANSI) MC96.1-1982		
Standard	+870 °C ... +1700 °C	± 0.5 %

1) |t| is the value of the temperature in °C without consideration of the sign.

2) Whichever is larger.

Limiting error with selected temperatures in °C for Type B thermocouples

Temperature (ITS 90) °C	Limiting error DIN EN 60 584 Part 2	
	Class 2 °C	Class 3 °C
700	± 1.8	± 4.0
800	± 2.0	± 4.0
900	± 2.3	± 4.5
1000	± 2.5	± 5.0
1100	± 2.8	± 5.5
1200	± 3.0	± 6.0
1300	± 3.3	± 6.5
1400	± 3.5	± 7.0
1500	± 3.8	± 7.5
1600	± 4.8	± 8.0

The long-term stability of precious metal thermocouples rises with an increase in the diameter of the thermoelectric wire. Therefore, the Type S, R and B sensors are available with thermoelectric wire diameters of Ø 0.35 mm or Ø 0.5 mm.

Potential measuring uncertainties due to aging effects

Thermocouples age and change their temperature/thermo-electric voltage curve. Types J (Fe-CuNi) and T (Cu-CuNi) thermocouples age slightly due to oxidation of the pure metal leg. As for Types K and N (NiCrSi-NiSi) thermocouples, considerable changes in thermoelectric voltage can occur at high temperatures due to chromium depletion in the NiCr leg, which results in a decreasing thermo-electric voltage. This effect is accelerated if there is a shortage of oxygen, since a complete oxide skin is unable to form on the surface of the thermocouple and protect it from further oxidation. The chromium oxidizes in the alloy, giving rise to the „**green rot**“ that, eventually destroys the thermocouple. The Ni leg is often damaged by sulphur, which occurs, for example, in flue gases. During the fast cooling of NiCr-Ni thermocouples, that has been operating at temperatures above 700 °C, certain states occur within the crystal structure (**short-range order**), which in Type K elements can result in a change in thermoelectric voltage of up to 0.8 mV (K effect). It has been possible to reduce the **short-range order effect** in Type N (NiCrSi-NiSi) thermocouples by alloying both legs with silicon. The effect is reversible and can be cancelled by annealing above 700 °C with subsequent slow cooling. Thermocouples with

smaller diameters react sensitively in this respect. Even cooling in still air can cause deviations greater than 1 K. Types R and S PtRh-Pt thermocouples display practically no aging up to 1400 °C, but they are highly sensitive to impurities. Silicon and phosphorus destroy the platinum very quickly. Silicon, which in the presence of Pt can be released from insulating ceramics even in weakly reducing atmospheres (reduction from SiO₂ to Si), alloys with the Pt limb of the element and causes measuring errors of 10 K and more, even with quantities of only a few ppm. Production has to proceed, therefore, with very great care.

Design

Based on the connection head-type and the thermowell material, a variety of designs is subdivided into the following main models as per DIN EN 50 446: AM, AMK, BM, BMK, AK, AKK, BK

1st character

A = Connection head, Form A

B = Connection head, Form B

2nd character

M = Metal thermowell

K = Ceramic thermowell

3rd character

K = Ceramic inner tube

no 3rd character: without inner tube

Designs with metal thermowell

Depending on the material used the upper operating temperature limit of metal thermowells can be up to 1200 °C. Generally a non-precious metal thermocouple is used as a sensor (Type K, J and N).

Design with ceramic thermowell

Depending on the ceramics used the upper operating temperature limit of ceramic thermowells can be up to 1600 °C, with higher temperatures on request. Generally a precious metal thermocouple is used as a sensor (Type R, S and B).

For the measurement of temperatures above 1200 °C only precious metal thermocouples can be used.

With precious metal thermocouples, however, there is a risk of 'poisoning' by foreign substances. This risk rises with increasing temperatures. Therefore, at temperatures above 1200 °C gastight ceramics, preferably high-purity C 799, should be used (see "Remarks on the selection and operation of thermowells" on page 11).

The process connection can be gastight up to 1 bar. It is recommended that with toxic or safety-critical process gases, or special installations, further constructive measures be taken in addition to the standard features in order to avoid any leakage of the medium to the outside via the connection head, in the case of a thermowell fracture (e.g. pressure-sealed leadthrough in the connection head).

Model survey and dimensions

Dimensions for standard versions in mm

Model TC80-O

Design AK per DIN EN 50 446

- Connection head, Form A
- Ceramic thermowell
- Metallic support tube

Dimensions for versions with thermowell diameter ≥ 24 mm

A	Nominal length	500, 710, 1000, 1400, 2000 ¹⁾
$\varnothing F$	Thermowell outer \varnothing	24, 26 (SIC, C 530)
N	Support tube length	200 (standard)
$\varnothing F_4$	Support tube \varnothing	32

¹⁾ These nominal lengths (and greater lengths) with precious metal thermocouples inserted are not suitable for installation at right angles.

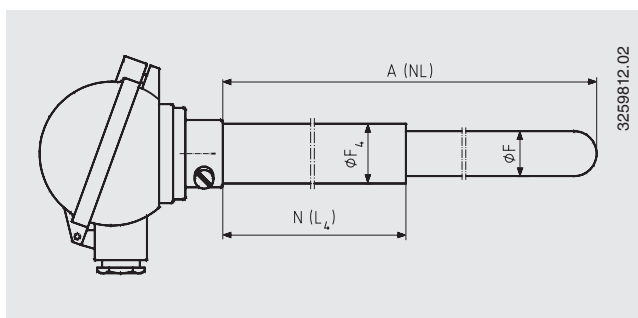

Dimensions for versions with thermowell diameter < 24 mm

A	Nominal length	500, 710, 1000 or 1400
$\varnothing F$	Thermowell outer \varnothing	15, 16 (16 for C 610)
N	Support tube length	150 (standard)
$\varnothing F_4$	Support tube \varnothing	22

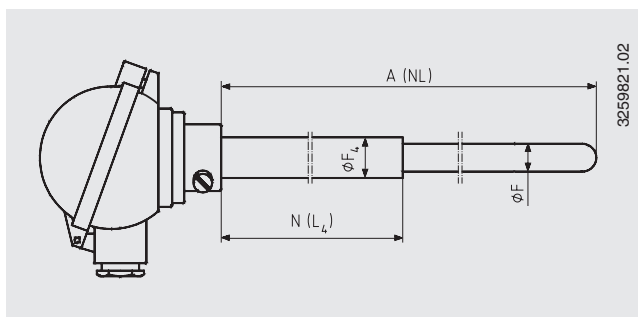

Model TC80-R

Design AKK per DIN EN 50 446

- Connection head, Form A
- Ceramic thermowell
- Metallic support tube
- Ceramic inner tube

Dimensions for versions with thermowell diameter ≥ 24 mm

A	Nominal length	500, 710, 1000 or 1400
$\varnothing F$	Thermowell outer \varnothing	24, 26 (SIC, C 530)
N	Support tube length	200 (standard)
$\varnothing F_4$	Support tube \varnothing	32

Dimensions for versions with thermowell diameter < 24 mm

A	Nominal length	500, 710, 1000 or 1400
$\varnothing F$	Thermowell outer \varnothing	15, 16 (C 610)
N	Support tube length	150
$\varnothing F_4$	Support tube \varnothing	22

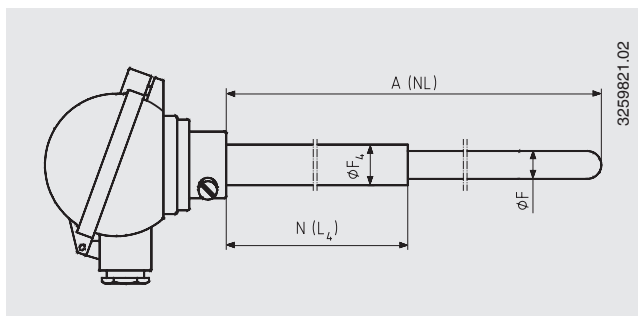
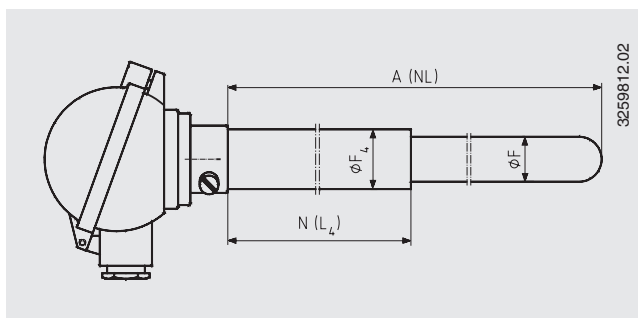

Model TC80-U

Design BK per DIN EN 50 446

- Connection head, Form B
- Ceramic thermowell
- Metallic support tube

A	Nominal length	355, 500, 710, 1000
ØF	Thermowell outer Ø	10
N	Support tube length	80
ØF ₄	Support tube Ø	15

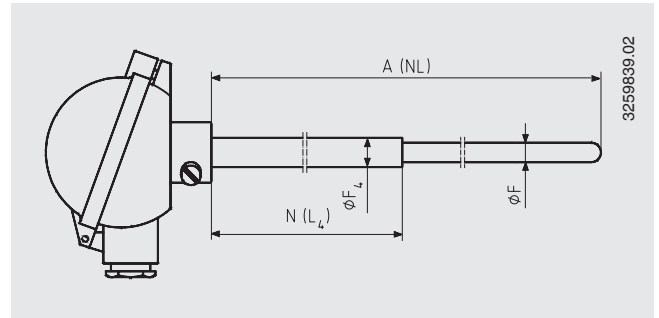

Model TC80-P / TC80-Q

Design AM / AMK per DIN EN 50 446

- Connection head, Form A
- Metal thermowell
- Ceramic inner tube (TC80-Q / AMK)

A	Nominal length	500, 710, 1000, 1400, 2000 ¹⁾
ØF	Thermowell outer Ø	22 (24, 26)

¹⁾ These nominal lengths (and greater lengths) with precious metal thermocouples inserted are not suitable for installation at right angles.

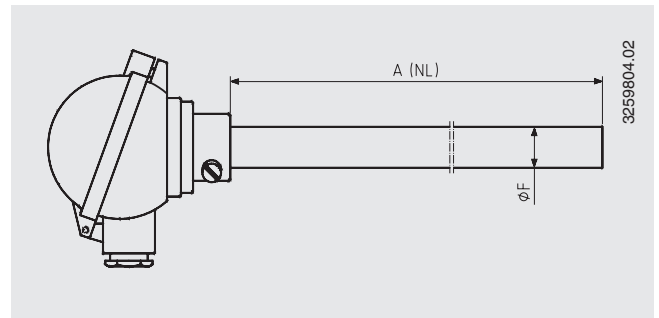

Model TC80-S / TC80-T

Design BM / BMK per DIN EN 50 446

- Connection head, Form B
- Metal thermowell
- Ceramic inner tube (TC80-T / BMK)

A	Nominal length	355, 500, 710, 1000, 1400 ¹⁾
ØF	Thermowell outer Ø	15

¹⁾ only TC80-S

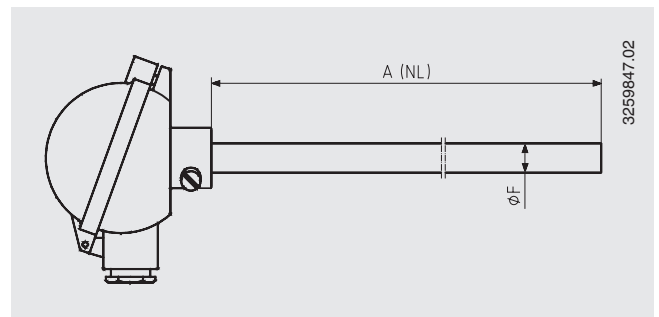

Connection head

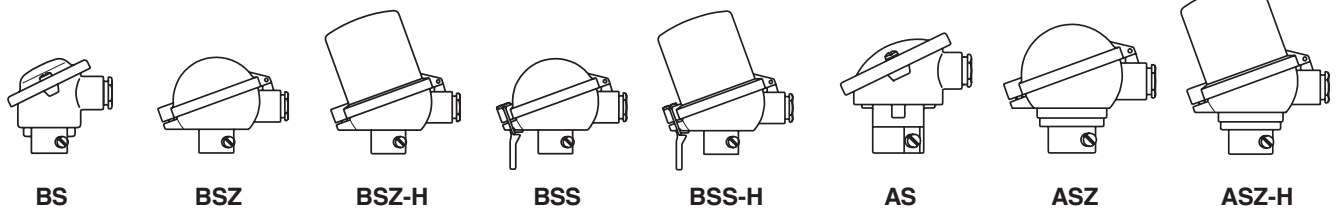

Model	Material	Cable entry	Ingress protection	Cap	Surface finish
BS	Aluminium	M20 x 1.5 ¹⁾	IP 53	Cap with 2 screws	blue, painted ²⁾
BSZ	Aluminium	M20 x 1.5 ¹⁾	IP 53	Flap cap with screw	blue, painted ²⁾
BSZ-H	Aluminium	M20 x 1.5 ¹⁾	IP 53	Flap cap with screw	blue, painted ²⁾
BSS	Aluminium	M20 x 1.5 ¹⁾	IP 53	Flap cap with clip	blue, painted ²⁾
BSS-H	Aluminium	M20 x 1.5 ¹⁾	IP 53	Flap cap with clip	blue, painted ²⁾
AS	Aluminium	M20 x 1.5 ¹⁾	IP 53	Cap with 2 screws	blue, painted ²⁾
ASZ	Aluminium	M20 x 1.5 ¹⁾	IP 53	Flap cap with screw	blue, painted ²⁾
ASZ-H	Aluminium	M20 x 1.5 ¹⁾	IP 53	Flap cap with screw	blue, painted ²⁾

Designs with ingress protection IP 65 on request

¹⁾ Standard

²⁾ RAL5022, polyester paint saltwater-proof

Transmitter option)

The transmitter can be directly mounted into the thermometer (head mount). The permissible ambient temperature of the transmitter as specified in the relevant data sheet must be observed. In the case of the direct connection of the thermocouple to the transmitter, the risk of inadmissibly high heating of the transmitter terminals rises due to the thermal conduction of the thermoelectric wires. Therefore the thermocouple can also be indirectly connected to the transmitter via a short piece of thin compensating cable between terminal block and transmitter.

Since the transmitter thus has to be mounted within the cap of the connection head, this cap needs to be relatively high: head ASZ-H for thermometers TC80-O, TC80-P, TC80-Q and TC80-R or head BSZ-H or BSS-H for thermometers TC80-S, TC80-T and TC80-U.

Connection head	Transmitter Model				
	T12	T19	T32	T91	T53
BS	-	-	-	-	-
BSZ	-	-	-	-	-
BSZ-H	•	•	•	•	•
BSS	-	-	-	-	-
BSS-H	•	•	•	•	•
AS	-	-	-	-	-
ASZ	-	-	-	-	-
ASZ-H	•	•	•	•	•

- Mounted within the cap of the connection head
- Mounting not possible

Model	Description	Data sheet
T19	Analogue transmitter, configurable	TE 19.03
T12	Digital transmitter, PC-configurable	TE 12.03
T32	Digital transmitter, HART protocol	TE 32.03 + TE 32.04
T53	Digital transmitter FOUNDATION Fieldbus and PROFIBUS PA	TE 53.01
T91	Analogue transmitter, fixed measuring ranges	TE 91.01

Assembly of the thermocouples

Non-precious metal thermocouple type K, N, J

Thermoelectric wire: \varnothing 1 mm or \varnothing 3 mm
 Insulation: insulating tube, ceramic C 610

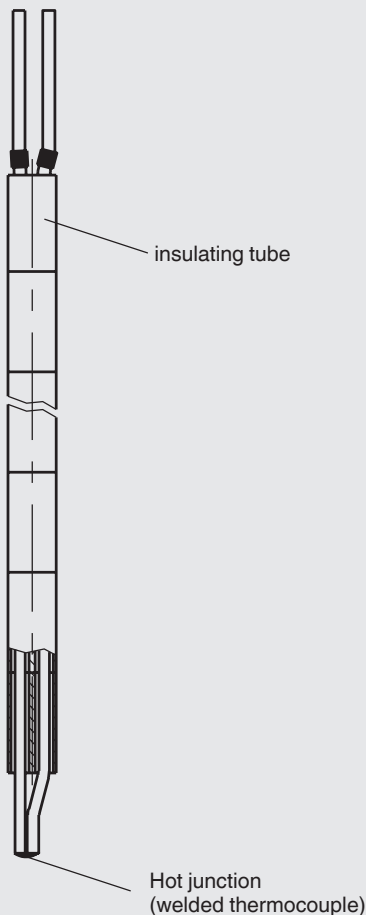

Precious metal thermocouple type S, R, B

Thermoelectric wire: \varnothing 0.35 mm or \varnothing 0.5 mm
 Insulation: insulating rod, ceramic C 799

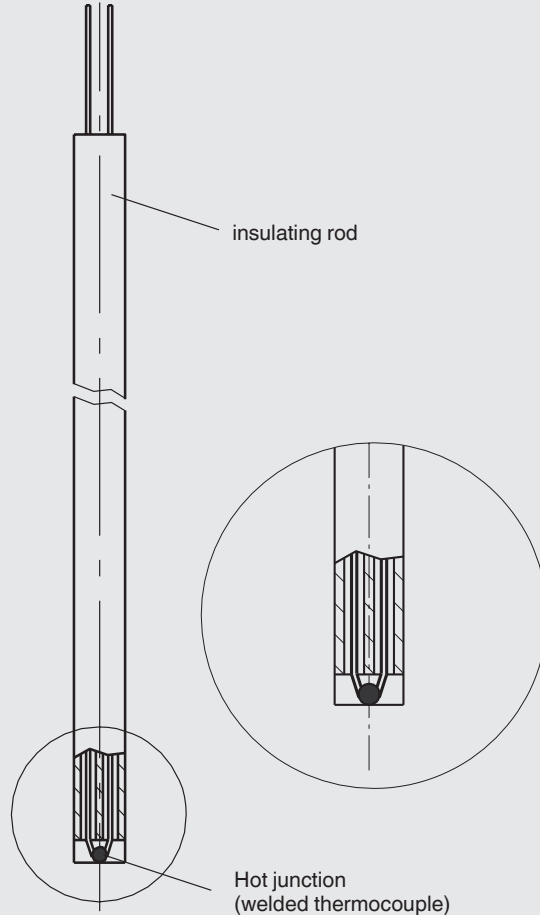

Model TC80-P / TC80-Q (AM / AMK) Model TC80-S / TC80-T (BM / BMK)

Metal thermowell

The thermowell is made of tube per DIN EN 50 446 Form A (dished) or Form C (flat). Both variants should be considered to be technically equivalent. The selection of the base form is the responsibility of the manufacturer.

In the case of enamelled thermowells the bottom is always dished. The thermowell is pressed into the connection head and clamped.

Additionally we offer the possibility of a head bolted onto the thermowell. Thus IP 65 protection is achieved. An adjustable process connection is fixed onto the thermowell, thus allowing a variable insertion length.

Standard nominal lengths to DIN EN 50 446 are preferred.

Standard nominal lengths

A = 500, 710, 1000, 1400, 2000 mm
others on request

Materials for metal thermowells

See "Remarks on the selection and operation of thermowells" on page 11

Inner tube (option)

At high temperatures metal thermowells might become porous or oxidised.

A gastight, ceramic inner tube protects the thermocouple from aggressive gases. As a result changes, in the thermo-electric properties of the thermocouple are avoided, and, in addition, the service life of the thermometer is generally prolonged.

Materials for inner tube ¹⁾

- Ceramic C 610 gastight
up to 1500 °C, not resistant to alkali vapours
- Ceramic C 799 gastight, high-purity
up to 1600 °C, however only partially resistant to changes in temperature, not resistant to alkali vapours

1) see „Remarks on the selection and operation of thermowells“ on page 11

Thermowell design

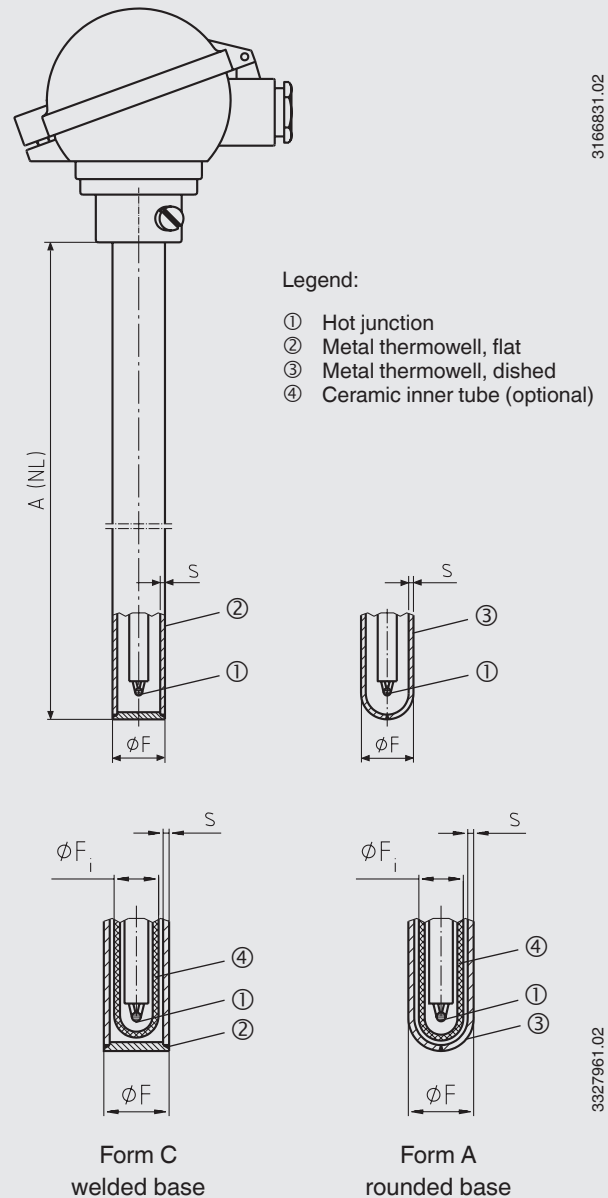

3166831.02

3327961.02

Dimensions in mm for thermowell and inner tube

Model	Metal thermowell outer Ø Ø F	tube thickness s	Ceramic inner tube outer Ø Ø Fi
TC80-P	22	2	15
TC80-S	15	2	10

Model TC80-R (AKK)
Model TC80-O (AK)
Model TC80-U (BK)

Ceramic thermowell

Ceramic thermowells are made from fired aluminium oxide ceramics, the tip is spherical. Due to the low mechanical strength, a metal support tube is used to fix the process connection to the thermometer.

The ceramic thermowell is cemented into the support tube using a fireproof ceramic compound. The support tube is inserted into the connection head and clamped. Standard nominal lengths to DIN EN 50 446 are preferred.

Standard nominal lengths

A = 355, 500, 710, 1000, 1400, 2000 mm
 others on request

Materials for ceramic thermowells 1)

- Ceramic C 530 not gastight, fine-pored highly-resistant to changes in temperature, useable up to 1600 °C, not attacked by gases
 Used as outer thermowell in combination with gastight inner thermowell
 - Ceramic C 610 gastight
 up to 1500 °C, not resistant to alkali vapours
 - Ceramic C 799 gastight, high-purity
 up to 1600 °C, however only partially resistant to changes in temperature, not resistant to alkali vapours
- other materials on request

Inner tube (optional, only with model TC80-R)

If the outer thermowell selected for model TC80-R is from C 530 non-gastight ceramic, it should be combined with a gastight inner tube to protect the thermocouple from aggressive gases.

As a result, changes in the thermoelectric properties of the thermocouple are avoided, and, in addition, the service life of the thermometer is generally prolonged.

Materials for inner tube 1)

- Ceramic C 610 gastight
 up to 1500 °C, not resistant to alkali vapours
- Ceramic C 799 gastight, high-purity
 up to 1600 °C, however only partially resistant to changes in temperature, not resistant to alkali vapours

1) see „Remarks on the selection and operation of thermowells“ on page 11

Thermowell design

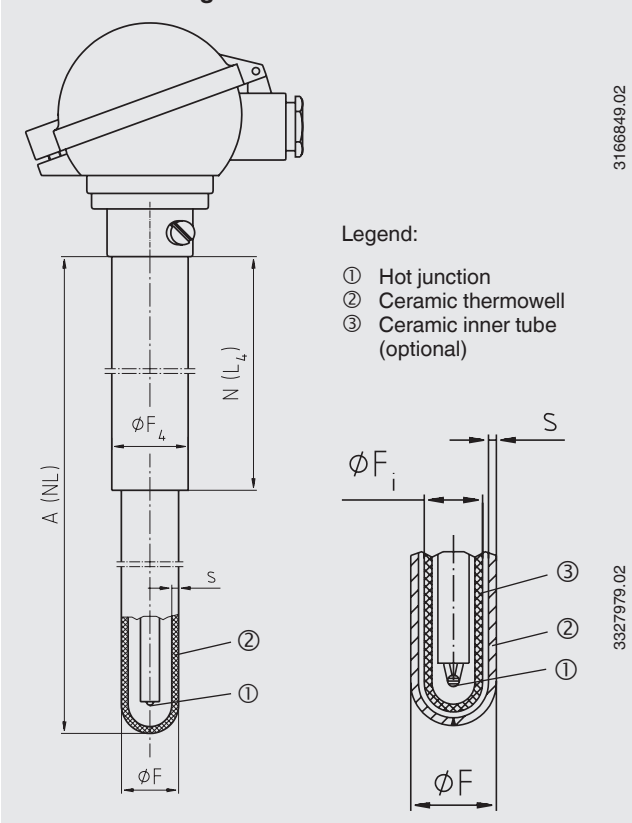

3166849.02

3327979.02

Dimensions in mm for thermowell and inner tube

Model	Ceramic thermowell outer Ø Ø F	tube thickness s	Ceramic inner tube outer Ø Ø Fi
TC80-R	22, 26	2 - 4	15, 16
TC80-R	15, 16	2	10

Support tube

Material: carbon steel, stainless steel
 other materials on request

Dimensions in mm for support tube

Model	Outer Ø Ø F4	Length N (L4)
TC80-O	32	200
TC80-O	22	150
TC80-R	32	200
TC80-R	22	150
TC80-U	15	150

**Model TC80-P / TC80-Q (AM / AMK)
Model TC80-S / TC80-T (BM / BMK)**

Enamelled thermowell

When using enamelled thermowells a threaded bushing should be used to prevent the enamel layer from being damaged.

Not gastight

A stop flange is sufficient; a mating flange is not necessary. The stop flange slides onto the thermowell and is secured using a clamp. Therefore, the insertion length of the thermometer is variable and can be easily adjusted at the mounting point.

Gastight up to 1 bar ¹⁾

A threaded bushing or a combination stop flange / mating flange is needed.

Threaded bushing:

This is secured onto the metal thermowell using a clamp. After loosening the clamp, the threaded bushing slides onto the thermowell. Therefore, the insertion length of the thermometer is variable and can be easily adjusted at the mounting location.

Stop flange / mating flange:

Sealing is made via a stuffing-box packing between mating flange and thermowell. The assembly is secured by clamping the stop flange and thermowell together. The insertion length of the thermometer is variable.

Mounting example: thermocouple with metal thermowell

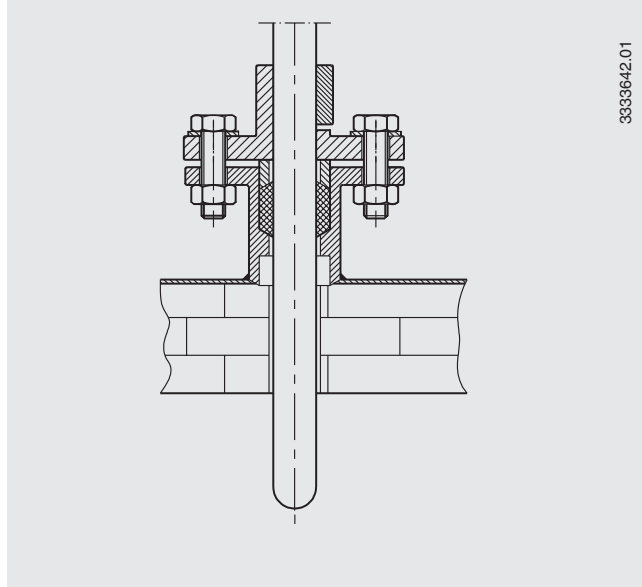

**Model TC80-R (AKK)
Model TC80-O (AK)
Model TC80-U (BK)**

Not gastight

A stop flange is sufficient; a mating flange is not necessary. The stop flange slides on the support tube and is secured using a clamp. Therefore, the insertion length is variable, within the limits of the support tube length, and can be easily adjusted at the mounting point.

Gastight up to 1 bar ¹⁾

A threaded bushing or a combination stop flange / mating flange is needed.

Threaded bushing:

This is secured onto the support tube using a clamp. After loosening the clamp, the threaded bushing slides onto the thermowell. Therefore, the insertion length of the thermometer is variable, within the limits of the support tube length, and can be easily adjusted at the mounting point.

Stop flange / mating flange:

Sealing and assembly is made by clamping the mating flange and metallic support tube together.

1) see „Remarks on the selection and operation of thermowells“ on page 11

Mounting example: thermocouple with ceramic thermowell

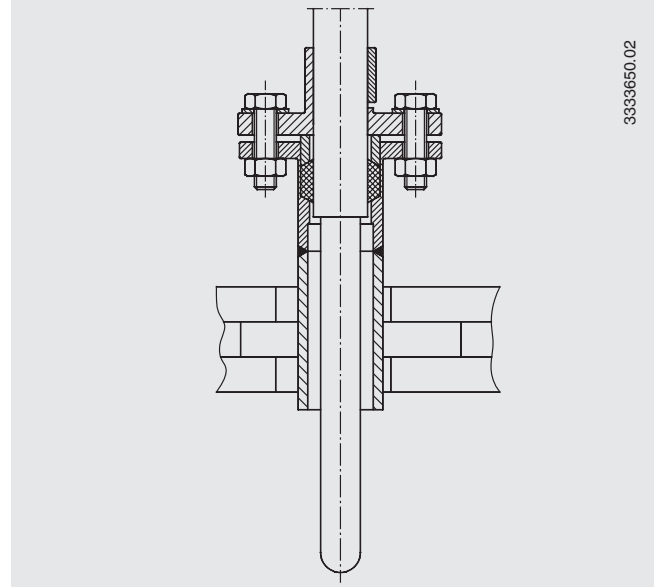

Installation notes for ceramic thermowells

The C 799 ceramic material is only partially resistant to changes in temperature. A temperature shock can therefore easily result in stress cracks and consequently in damage to the ceramic thermowell. For this reason thermometers with thermowells of C 799 ceramic must be pre-heated before installation, and subsequently they should be slowly immersed into the process.

Depending on the ambient and process temperatures, this procedure is also recommended for the other ceramic materials.

In addition to protection from thermal stress, ceramic thermowells must also be protected from mechanical stress. Such negative stress conditions are caused by bending forces acting in a horizontal installation position.

Thus, with horizontal installation and dependent upon diameter, nominal length and design, additional support should be provided on site.

The note regarding the problems caused by bending forces also applies to metal thermowells.

Process connection

Threaded bushing

adjustable,
gastight up to 1 bar
Sealing: asbestos free,
up to max. 300 °C,
higher temperatures
on request

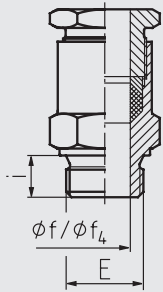

Material:
carbon steel or
stainless steel 1.4571

Stof flange per DIN EN 50 446 adjustable

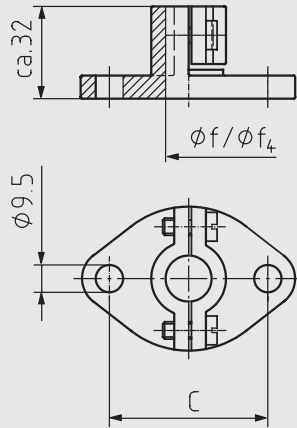

Material:
carbon steel or malleable cast iron
others on request

Mating flange only appli- cable in conjunction with a stop flange

adjustable,
gastight up to 1 bar
Sealing: asbestos-free

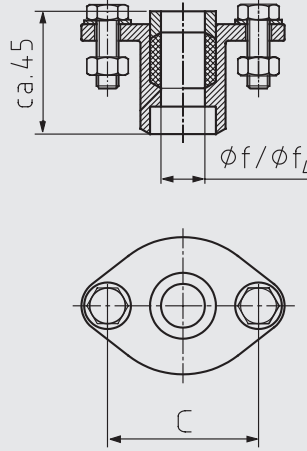

3163059.04

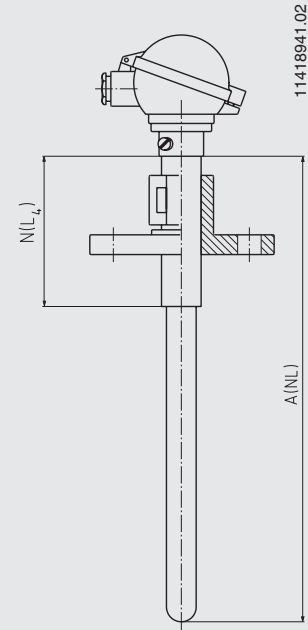

Selectable threaded bushings

Model	Thermowell outer Ø	Dimensions in mm		Process connection
		Ø f/f ₄	i min. E	
TC80-P	22	22.5	20	G 1, 1 NPT, G 1½
TC80-Q				
TC80-S	15	15.5	20	G ½, G ¾, G 1, 1½ NPT,
TC80-T				M20 x 1.5, M27 x 2

other threads on request

Selectable threaded bushings

Model	Thermowell outer Ø	Dimensions in mm		Process connection
		Ø f/f ₄	i min. E	
TC80-O	32	32.5	30	G 1¼
TC80-O	22	22.5	20	G 1, 1 NPT
TC80-U	15	15.5	20	G ½, G ¾, G 1

other threads on request

Selectable stop flanges

Model	Thermowell outer Ø	Dimensions in mm	
		Ø f/f ₄	C (hole spacing)
TC80-P	22	22.5	70
TC80-Q			
TC80-S	15	15.5	55
TC80-T			

Selectable stop flanges

Model	Thermowell outer Ø	Dimensions in mm	
		Ø f/f ₄	C (hole spacing)
TC80-O	32	32.5	70
TC80-O	22	22.5	70
TC80-U	15	15.5	55

TC-80 with solid-welded flange connection

Flanges can be specified in various nominal sizes, pressure ratings and materials.

As standard, the flange is welded, using a double fillet weld, to the metallic extension neck or to the metallic exterior thermowell.

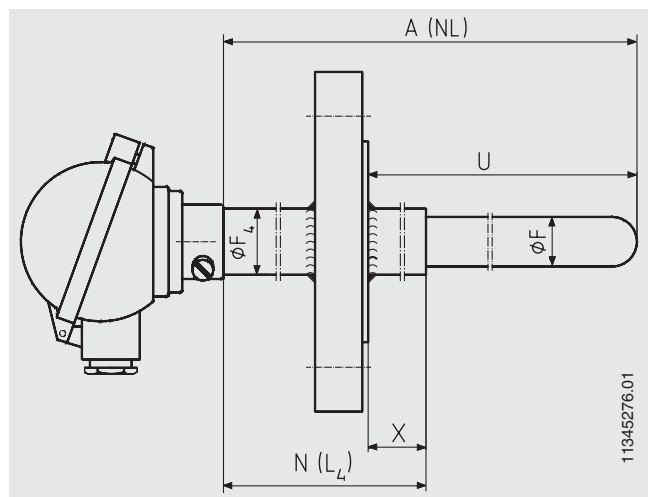

Special assemblies

In addition, for particularly unusual or critical applications, we offer high-temperature thermocouples in special designs. These variants can be made with, among others, pressure

tight sealing, inert gas or compressed air purging, flange cooling. Coated thermowells for specific applications are also possible, as is platinum coating.

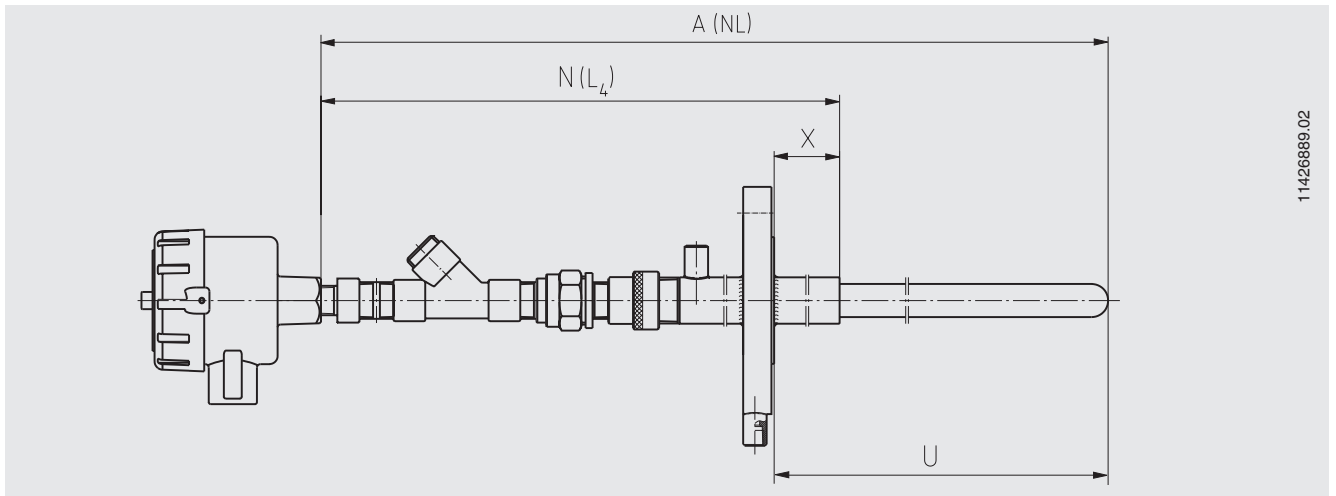

11426889.02

Remarks on the selection and operation of thermowells

Ceramic thermowells should be considered to be gas-tight in accordance with the DIN EN 50 446 standard. A diffusion of gas from the process into the sensor cannot be ruled out, particularly at high temperatures. As a result of this, the resistance of the thermocouple material to the medium should be explicitly considered.

The responsibility for the choice of materials for the safe function of the thermometer/thermowell within the plant/machinery is the responsibility of the customer/operator. WIKA can only offer recommendations which are based on our experience in similar applications.

The following table does not claim to be extensive. All information is non-binding and does not represent guaranteed characteristics. They should be fully tested by the customer using the conditions of the respective application.

Resistance when in contact with gases

Material No.	AISI No.	Usable in air up to °C	Resistance against sulphurous gases oxidising	Resistance against sulphurous gases reducing	nitrogenous, low-oxygen gases	Carburisation
1.0305		550	low	low	medium	low
1.4571	316Ti	800	low	low	medium	medium
1.4762		1200	very high	high	low	medium
1.4749	446	1150	very high	high	low	medium
1.4841	310 / 314	1150	very low	very low	high	low
1.4876		1100	low	low	high	very high

Operation with gases

Material No.	Application
1.0305 (St35.8)	Temperature furnaces for heat treatment processes, galvanising and tinning plants, carbon-dust-air mixture pipelines in steam power stations
1.0305 enamelled (St35.8 enamelled)	Flue-gas desulphurisation plants, white metal, lead and tin smelters
1.4762 X 10 CrAlSi 25	Combustion exhaust gases, cement and ceramic furnaces, heat treatment processes, annealing furnaces
1.4749 X 18 CrNi 28	Flue ducts, cooling furnaces
Kanthal Super (Molybdenised)	Glass and ceramics industry, coal liquification, refuse incinerators
1.4841 X 15 CrNiSi 25-21	Combustion chambers, industrial furnaces, petrochemical industry, cowper stoves, cyanide baths

Operation in melting plants

Material No.	Application	Temperature range
1.4841	Aluminium	up to 700 °C
1.1003	Magnesium (magnesium-containing aluminium)	
1.0305	Babbitt metal	up to 600 °C
1.0305	Lead	up to 700 °C
1.4841	Lead	up to 700 °C
2.4867	Lead	up to 700 °C
1.0305	Zinc	up to 480 °C
1.4749	Zinc	up to 480 °C
1.4762	Zinc	up to 480 °C
1.1003	Zinc	up to 600 °C
1.0305	Tin	up to 650 °C
1.4762	Copper	up to 1250 °C
1.4841	Copper-zinc alloy	up to 900 °C

Electrical connection

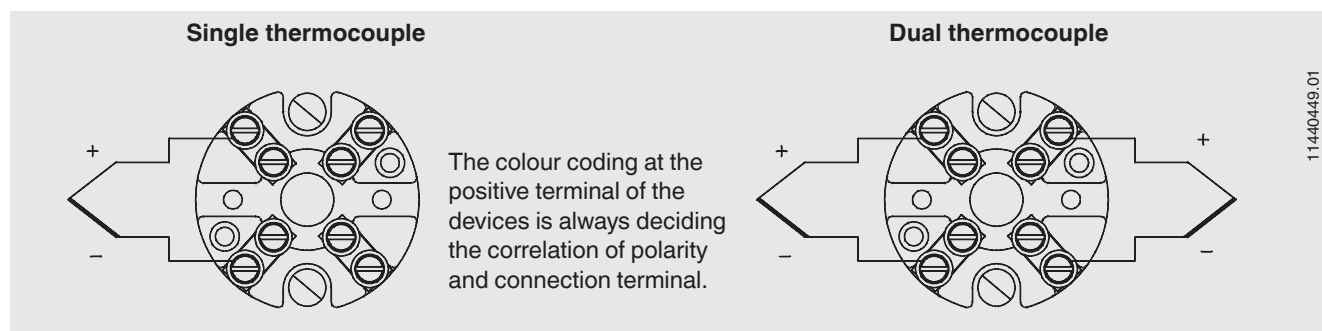

Colour coding of the terminal block

Sensor Type	DIN EN 60 584-3		ISA (ANSI) MC96.1-1982	
	Positive terminal	Negative terminal	Positive terminal	Negative terminal
K	green	white	yellow	red
N	pink	white	orange	red
J	black	white	white	red
S	orange	white	black	red
R	orange	white	black	red
B	grey	white	grey	red

The specifications given in this document represent the state of engineering at the time of publishing. We reserve the right to make modifications to the specifications and materials.

