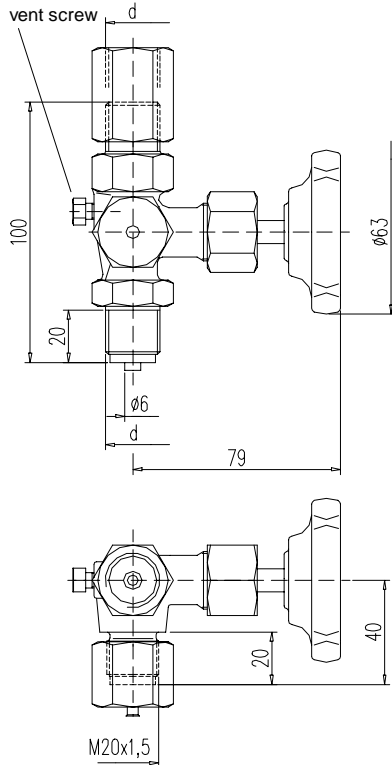
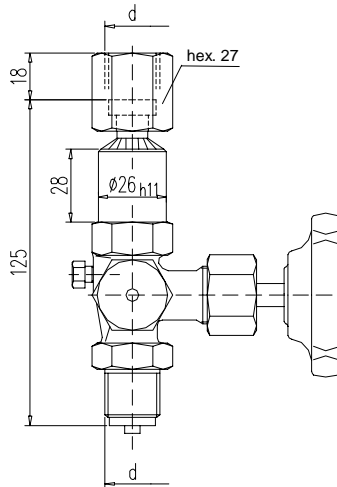
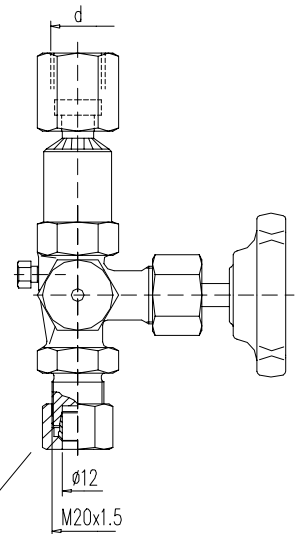

Design A

 with adjusting nut
DIN 16 283

Design B

 with swivel nut and shaft for
pressure gauge support

Design B - AS12

 tube fitting
O. D. 12 mm
line S

Please note: Pressure gauge valves with thread 1/2 NPT
see catalogue page 9.27

MOUNTING ACCESSORIES see section 10

PN ³⁾	Connection thread d	Material	Part no.		
			Design A	Design B	Design B-AS12
250 400 400	G 1/2	brass	S004.17.000	S004.17.020	S004.17.020.13
		steel	S004.17.100	S004.17.120	S004.17.120.13
		st. st.	S004.17.200	S004.17.220	S004.17.220.13
250 400 400	M 20x1,5	brass	S004.17.050	-	-
		steel	S004.17.150	-	-
		st. st.	S004.17.250	-	-

Components	Brass ¹⁾	Steel	Stainless steel ¹⁾
	DIN - Material Number		
Body ²⁾	brass	1.0460	1.4571
Valve stem	1.4104		1.4571
Needle tip	1.4104		1.4571
Packing	PTFE up to 200°C (graphite up to 250°C)		
Sealing cap	steel	stainless steel	
Union nut	steel	stainless steel	
Adjusting nut	steel		stainless steel
Swivel nut	brass	steel	stainless steel
Vent screw	1.4571		
Handwheel	plastic		

Abbreviation acc. to DIN	Material	Temperature rating
10 Ms	brass	- 10 up to + 120°C
10 St	steel	- 10 up to + 120°C
20 St	stainless steel	- 20 up to + 200/250°C

- **Body:** brass: pressed part
steel / stainless steel: die-pressed part
- **Surface:** steel phosphatized
- Internal stem thread
- Stem with cold rolled surface and non-rotating needle tip

- 1) Can also be supplied for oxygen service.
Please notice order instruction B 3!
- 2) Available with inspection certificate 3.1
acc. to EN 10 204
- 3) Valves with PN 640 on request