

- Force sensors and load cells
- Measurement amplifiers
- Mechanical and electronic accessories
- Combination units
- Force calibration systems

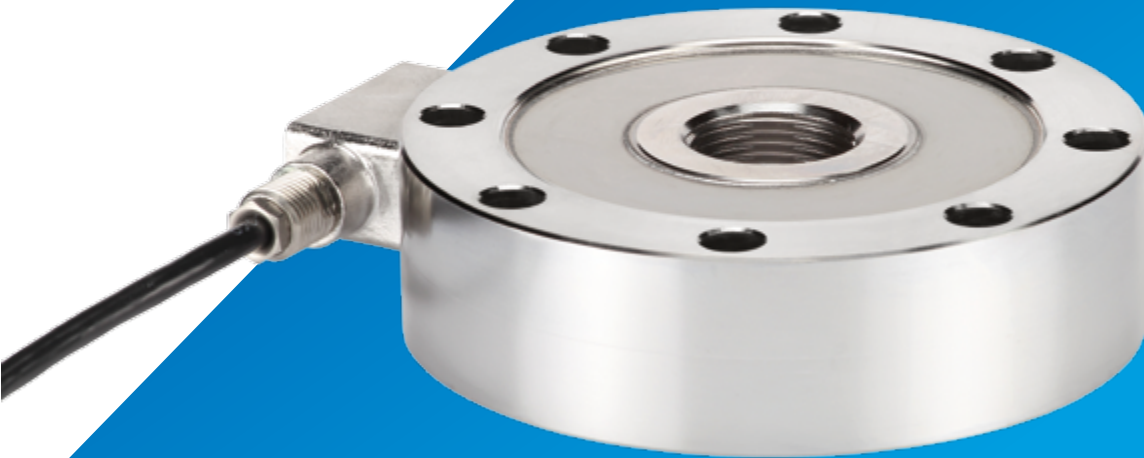

FORCE AND WEIGHT MEASURING INSTRUMENTS





Precise force measurement in many areas

Application areas

Force and weight measurement is part and parcel of a large number of industrial applications. For applications such as measuring forces in packaging or filling machines, weighing silos in outdoor areas, measuring operating forces in the development of new products or force measurement in testing machines – SIKA offers a comprehensive range of components for industrial force measurement. For all aspects of testing machines, we supply sensors that comply with ISO 376 and force calibration systems that consist of extremely accurate sensors and measurement amplifiers.

We also offer combination units for measuring all tensile and compression forces. These devices incorporate a sensor, a measurement amplifier and display as a single unit. Since they are equipped with an internal power supply, combination units can be quickly installed and are portable.

Our force sensors and load cells, measurement amplifiers, software and accessories can be used to create measurement solutions for numerous fields of application. In addition to our standard sensors, whose diverse application possibilities can cover virtually every application, we offer systems that are tailored to special applications. Contact us if you have specific requirements for a force measurement system. We can advise you on component selection. If necessary, we can also develop and manufacture special products tailored to your needs.

Force sensors and load cells

Measuring principle, output signals and options

All SIKA sensors are based on strain gauges in a full-bridge circuit. The sensors are designed to supply a measurement bridge signal of 2 mV/V as an output signal. The connection type is 4-wire; we can supply almost all versions with a 6-wire connection if required. Selected sensors are available with an integrated measurement amplifier and output signals 4...20 mA, ± 5 V or ± 10 V as options. In addition, we offer battery-powered sensors with wireless measurement data transfer in the 433 MHz range.

Differences between force sensors and load cells

SIKA produces sensors for measuring forces or weights. Some of our sensors are alternatively available as force sensors with output in newtons or as load cells with output in kilograms. An important difference between force sensors and load cells relates to the underlying standards:

- Force sensors are produced in accordance with the requirements of ISO 376
- Load cells correspond in their design to the international OIML-R60 regulation

A force sensor and load cell can therefore be mechanically identical, even if the classification, production sequence, calibration and output signal differ.

On request, we can also produce all load cells with the output signal as force (N / kN) or force sensors with the output signal as weight (kg / t). In this case, the sensor no longer conforms to the ISO 376 standard or OIML-R60. Instead, we indicate the error limits as a percentage.



Low-profile force transducers

FTC4

Our FTC low-profile sensor is a multi-purpose instrument in force measurement technology. Thanks to its low profile, low nominal displacement and high resonant frequency, the sensor is extremely versatile. Furthermore, the broad range of Rated forces from 5 kN to 5 MN makes the FTC4 attractive for a large variety of applications. This sensor is especially well suited for use in material testing machines. High resistance to lateral forces and torques, as well as versatile accessories, enable diverse installation options.

Performance features

- Available measuring ranges from 5 kN to 5 MN
- ISO 376
- Low overall height
- Easy process integration
- Hermetically sealed by laser welding
- High long-term measurement stability
- A large number of mechanical mounting aids are available

For optimal mounting, particularly in test machines, we offer suitable load flanges, knuckle eyes and other accessories for force transfer.

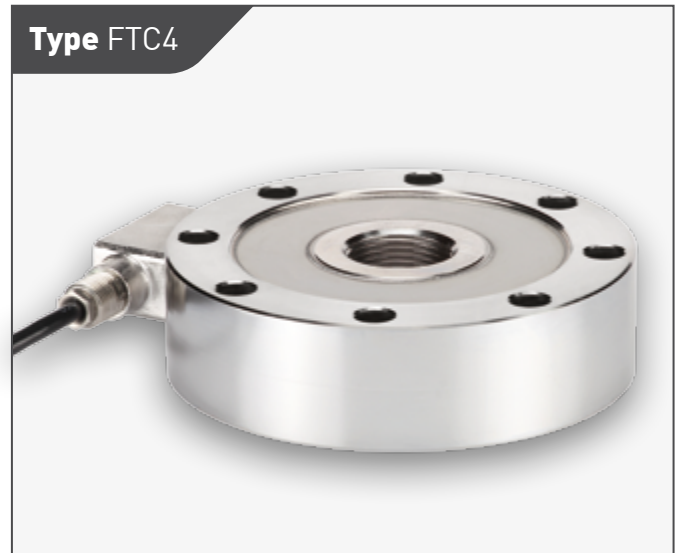

Options

- A version with a built-in measurement amplifier is available
- A version with wireless data transfer is available
- Centred through-hole without thread

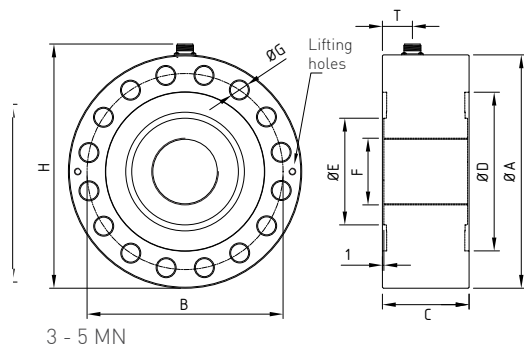
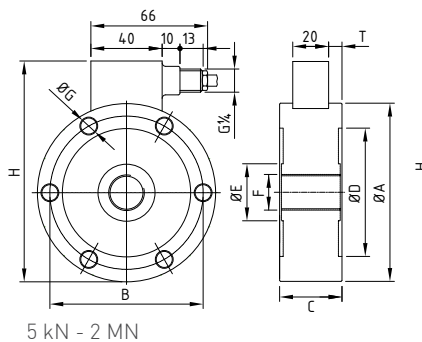

Load	Force	Dimensions [mm]										
		ØA	B	C	ØD	ØE	F	ØG	n °G	H	T	KHz*
0.5 / 1 t	5 / 10 kN	100	86	35	72	32	M20 x 1.5	9	6	121	7.5	2.5
2.5 t	25 kN											4.8
5 t	50 kN	127	110	35	92	47	M30 x 2	10.5	8	149	7.5	3.8
10 t	100 kN											5.8
20 t	200 kN	165	138	50	108	62	M42 x 3	17	12	188	15	5.7
30 t	300 kN			7.3								
50 t	500 kN			60								20
75 / 100 t	750 kN / 1 MN	230	185	80	145	98	M60 x 3	26	12	254	30	18.2
200 t	2 MN	300	250	100	198	132	M100 x 3	25	16	323	40	18
300 t**	3 MN**	350	294	120	238	160	M100 x 3	28	16	367	40	15.7
500 t**	5 MN**			130								

* Resonant frequency

** Maximum tensile load 250 t / 2.5 MN

Technical data

FTC4 force sensor		
Rated force	(F_{nom})	5 / 10 / 25 / 50 / 100 / 200 / 300 / 500 / 750 kN
		1 / 2 / 3 / 5 MN
Force transfer direction		Compression and tension
ISO 376 accuracy class		1
Rated characteristic value	(C_{nom})	2 mV/V
Material		Stainless steel
Degree of protection EN 60529		IP67
Encapsulation		Hermetically sealed by welding
Own weight		1.6 to 63 kg
Cable length		5 m
Nominal displacement	(s_{nom})	0.06 to 0.21 mm
Error limits		
Linearity		< 0.050 % of F _{nom}
Hysteresis		< 0.050 % of F _{nom}
Relative zero offset	(f ₀)	< 0.030 % of F _{nom}
Temperature effect on zero signal per 10 °C	(TK ₀)	< 0.028 % of F _{nom}
Temperature effect on characteristic value per 10 °C	(TK _C)	< 0.024 % of F _{nom}
Relative repeatability 0° / 120° / 240°	(b)	< 0.145 %
Relative interpolation error	(f _c)	< 0.090%
Relative reversibility	(u)	< 0.240 %
Electrical data		
Input resistance	(R _e)	800 ± 20 Ω (430 ± 20 Ω from 500 kN F _{nom})
Output resistance	(R _a)	705 ± 20 Ω (352 ± 20 Ω from 500 kN F _{nom})
Insulation resistance	(R _{is})	> 5 GΩ
Zero signal tolerance	(d ₀)	< 1% of F _{nom}
Supply voltage	(B _{nom})	1...15 V (typically 10 V)
Operating voltage	(B _G)	1...18 V
Maximum load		
Operating force	(F _G)	120 % of F _{nom}
Force limit	(F _L)	150 % of F _{nom}
Breaking force	(F _B)	> 300 % of F _{nom}
Lateral force limit	(F _Q)	100 % of F _{nom}
Maximum dynamic load		75 % of F _{nom}
Temperature data		
Reference temperature		23 °C
Nominal temperature range	(B _{nom})	-10...40 °C
Operating temperature range		-20...70 °C

Tensile and compression force sensors

FTCETM

In addition to the properties of an S-type force sensor, the FTCETM offers decisive advantages thanks to its cylindrical shape and large bearing area. In comparison with conventional S-type force sensors, the FTCETM allows very high Rated forces of up to 100 kN to be achieved. One of the main application areas for this sensor is in test machines. The FTCETM achieves an accuracy of $< \pm 0.030\%$ for both linearity and hysteresis.

Performance features

- Measuring ranges from 5 kN to 100 kN available
- Hermetically sealed by laser welding
- A large number of mechanical mounting aids are available
- Easy process integration

We supply matching accessories for the FTCETM force sensor. In addition to knuckle eyes for tensile load, you receive load transfer heads for compressive load.



Options

- A version with a built-in measurement amplifier is available
- A version with wireless data transfer is available

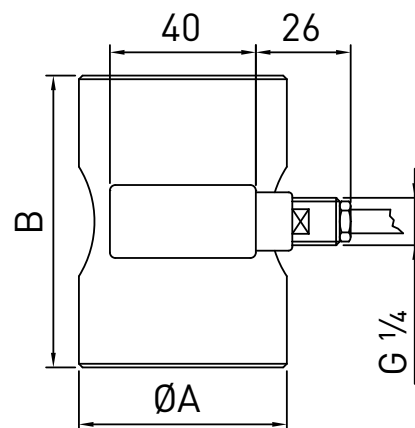
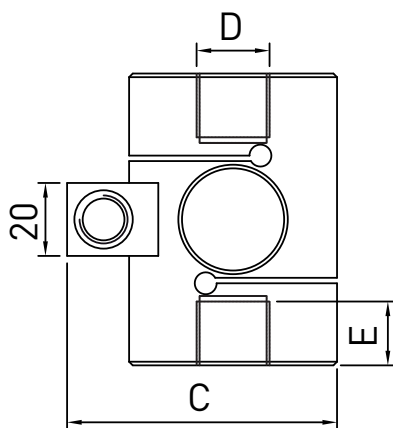

Force	Dimensions [mm]				
	ØA	B	C	D	E
5 / 10 / 25 kN	57	80	74.5	M20 x 1.5	17
50 / 75 / 100 kN	82	110	102	M30 x 2	20

Technical data

FTCETM force sensor			
Rated force	(F _{nom})	5 / 10 / 25 / 50 / 75 / 100 kN	
Force transfer direction		Compression and tension	
ISO 376 accuracy class		00	0.5
Rated characteristic value	(C _{nom})	2 mV/V	
Material		Stainless steel	
Degree of protection EN 60529		IP67	
Encapsulation		Hermetically sealed by welding	
Own weight		1.5 to 4.5 kg	
Cable length		5 m	
Nominal displacement	(s _{nom})	0.3 mm	
Error limits			
Linearity		< 0.030 % of F _{nom}	< 0.030 % of F _{nom}
Hysteresis		< 0.030 % of F _{nom}	< 0.030 % of F _{nom}
Relative zero offset	(f ₀)	< 0.010 % of F _{nom}	< 0.020 % of F _{nom}
Temperature effect on zero signal per 10 °C	(TK ₀)	< 0.030 % of F _{nom}	< 0.030 % of F _{nom}
Temperature effect on characteristic value per 10 °C	(TK _C)	< 0.011 % of F _{nom}	< 0.011 % of F _{nom}
Relative repeatability 0° / 120° / 240°	(b)	< 0.050 %	< 0.150 %
Relative interpolation error	(f _c)	< 0.020 %	< 0.055 %
Relative reversibility	(u)	< 0.070 %	< 0.250 %
Electrical data			
Input resistance	(R _e)	420 ± 20 Ω	
Output resistance	(R _a)	352 ± 2 Ω	
Insulation resistance	(R _{is})	> 5 GΩ	
Zero signal tolerance	(d ₀)	< 1 % of F _{nom}	
Supply voltage	(B _{nom})	1...15 V (typically 10 V)	
Operating voltage	(B _G)	1...18 V	
Maximum load			
Operating force	(F _G)	120 % of F _{nom}	
Force limit	(F _L)	150 % of F _{nom}	
Breaking force	(F _B)	> 300 % of F _{nom}	
Lateral force limit	(F _Q)	50 % of F _{nom}	
Maximum dynamic load		50 % of F _{nom}	
Temperature data			
Reference temperature		23 °C	
Nominal temperature range	(B _{nom})	-10...40 °C	
Operating temperature range		-20...70 °C	

FTSTM

Our FTSTM compact S-type force sensor is suitable for the precise measurement of tensile and compression forces in material testing machines and for use in cable force measurement. It also shows its strengths in many other industrial applications where precision and easy installation are required.

Other advantages are its good dynamic characteristics and easy force transfer over the two threads.

Performance features

- Measuring ranges from 0.5 kN to 5 kN available
- ISO 376
- Suitable for material test machines
- Hermetically sealed by laser welding
- High long-term measurement stability
- A large number of mechanical mounting aids are available
- Easy process integration

Options

Special material 1.4542

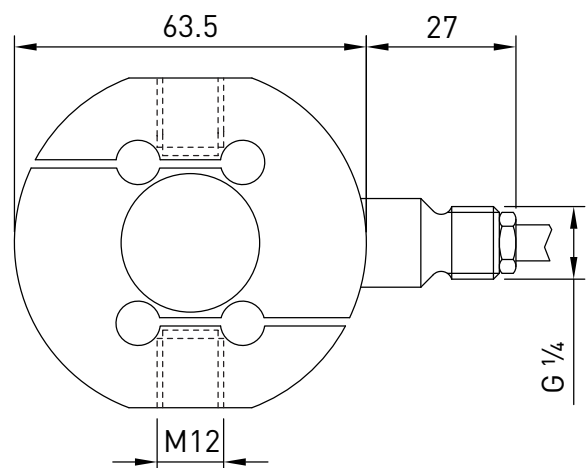
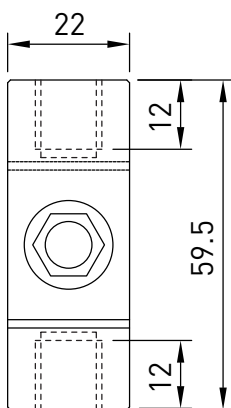

Technical data

FTSTM S-type force sensor			
Maximum capacity	(F _{nom})	0.5/1/2/3/5 kN	
Load transfer direction		Compression and tension	
ISO 376 accuracy class		00	0.5
Rated characteristic value	(C _{nom})	2 mV/V	
Material		Stainless steel	
Degree of protection EN 60529		IP67 (IP65 with F _{nom} 0.5 kN)	
Encapsulation		Hermetically sealed by welding	
Own weight		0.6 kg	
Cable length		5 m	
Nominal displacement		0.2 mm	
Error limits			
Linearity		< 0.020 % of F _{nom}	< 0.020 % of F _{nom}
Hysteresis		< 0.025 % of F _{nom}	< 0.025 % of F _{nom}
Relative zero offset	(f ₀)	< 0.010 % of F _{nom}	< 0.025 % of F _{nom}
Temperature effect on zero signal per 10 °C	(TK ₀)	< 0.025 % of F _{nom}	< 0.025 % of F _{nom}
Temperature effect on characteristic value per 10 °C	(TK _c)	< 0.025 % of F _{nom}	< 0.025 % of F _{nom}
Relative repeatability 0° / 120° / 240°	(b)	< 0.050 %	< 0.090 %
Relative interpolation error	(f _c)	< 0.020 %	< 0.040 %
Relative reversibility	(u)	< 0.070 %	< 0.100 %
Electrical data			
Input resistance	(R _e)	350 ± 20 Ω	
Output resistance	(R _a)	352 ± 2 Ω	
Insulation resistance	(R _{is})	> 5 GΩ	
Zero signal tolerance	(d ₀)	< 1 % of F _{nom}	
Supply voltage	(B _{nom})	1...15 V (typically 10 V)	
Operating voltage	(B _G)	1...18 V	
Maximum load			
Operating force	(F _G)	120 % of F _{nom}	
Force limit	(F _L)	150 % of F _{nom}	
Breaking force	(F _B)	> 300 % of F _{nom}	
Lateral force limit	(F _Q)	50 % of F _{nom}	
Maximum dynamic load		50 % of F _{nom}	
Temperature data			
Reference temperature		23 °C	
Nominal temperature range		-10...40 °C	
Operating temperature range		-10...70 °C	

Compression force transducers

FC8S

Robust and available in a wide variety of nominal loads: the SIKA FC8S force sensor. This force sensor is suitable for measuring static and dynamic compression forces and is versatile in use thanks to a wide range of mechanical accessories. They enable good force transfer even under difficult conditions.

We offer a large number of measuring ranges, starting with nominal loads up to 5 kN and extending to 200 times this smallest version with 1000 kN. Thanks to the low-profile design, low space requirements and small nominal displacement, our force sensors are attractive for a wealth of applications.

Performance features

- Measuring ranges from 5 kN to 1000 kN available
- ISO 376
- Low overall height
- Hermetically sealed by laser welding
- High long-term measurement stability
- A large number of mechanical mounting aids are available

Options

- A version with wireless measurement data transfer is available

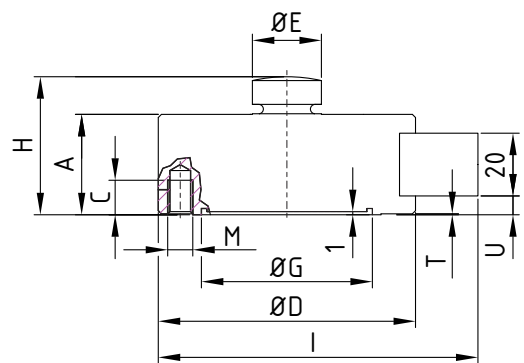
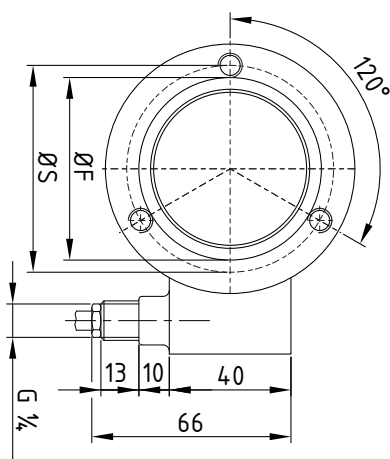

Force	Dimensions [mm]												
	A	C	ØD	ØE	ØF	ØS	ØG	H	I	M	n °M	T	U
5 / 10 / 25 / 50 / 75 / 100 kN	32	11	82	22	68	60	52.3	44	102	M8	3	0.3	6
200 / 300 kN	50	12	126	35	90	100	77.3	64	148	M8	3	0.5	15
500 / 750 / 1000 kN	60	20	165	60	130	115	92.3	80	188	M16	4	1	17

Technical data

FC8S force sensor			
Rated force	(F_{nom})	5 / 10 / 25 / 50 / 100 kN	200 / 300 kN 500 / 750 / 1000 kN
Force transfer direction		Compression	
ISO 376 accuracy class		0.5	1
Rated characteristic value	(C_{nom})	2 mV/V	
Material		Stainless steel	
Degree of protection EN 60529		IP67	
Encapsulation		Hermetically sealed by welding	
Own weight		2 to 9.4 kg	
Cable length		5 m	
Nominal displacement	(S_{nom})	0.06 mm	0.16 mm 0.23 mm
Error limits			
Linearity		< 0.030 % of F _{nom}	< 0.030 % of F _{nom}
Hysteresis		< 0.030 % of F _{nom}	< 0.030 % of F _{nom}
Relative zero offset	(f ₀)	< 0.020 % of F _{nom}	< 0.020 % of F _{nom}
Temperature effect on zero signal per 10 °C	(TK ₀)	< 0.030 % of F _{nom}	< 0.030 % of F _{nom}
Temperature effect on characteristic value per 10 °C	(TK _C)	< 0.020 % of F _{nom}	< 0.020 % of F _{nom}
Relative repeatability 0° / 120° / 240°	(b)	< 0.090 %	< 0.150 %
Relative interpolation error	(f _c)	< 0.045 %	< 0.090 %
Relative reversibility	(u)	< 0.120 %	< 0.200 %
Electrical data			
Input resistance	(R _e)	700 ± 2 Ω	
Output resistance	(R _a)	700 ± 2 Ω	
Insulation resistance	(R _{is})	> 5 GΩ	
Zero signal tolerance	(d ₀)	< 1 % of F _{nom}	
Supply voltage	(B _{nom})	1...15 V (typically 10 V)	
Operating voltage	(B _G)	1...18 V	
Maximum load			
Operating force	(F _G)	120 % of F _{nom}	
Force limit	(F _L)	150 % of F _{nom}	
Breaking force	(F _B)	> 300 % of F _{nom}	
Lateral force limit	(F _Q)	50 % of F _{nom}	
Maximum dynamic load		75 % of F _{nom}	
Temperature data			
Reference temperature		23 °C	
Nominal temperature range	(B _{nom})	-10...40 °C	
Operating temperature range		-20...70 °C	

FCM

Measuring forces in the smallest space is a special challenge for the sensor design. With the FCM miniature force sensor, we combine a very compact design with the accustomed high technical performance of our force sensors – precise measurements from up to 50 kN per sensor are possible.

Thanks to its low installation height and small diameter, the sensor is ideal for subsequent installation into existing processes. Extensive structural alterations are not required and the sensor only adds little net weight to the application. Compact scales and small test rigs are part of the core applications of the FCM.

Performance features

- Measurement ranges from 1 kN to 50 kN available
- Very small space requirement
- Laser-welded for complete insulation



Options

- Version available with built-in measurement amplifier
- Version available with reinforced base body

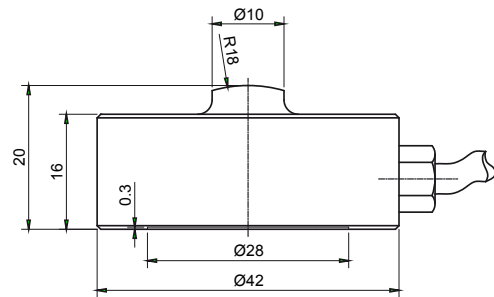
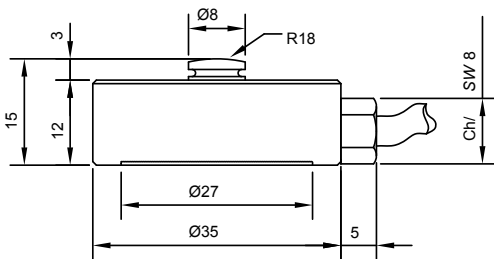

Technical data

FCM force sensor		
Rated force	(F _{nom})	1 / 2.5 / 5 / 10 / 25 / 35 / 50 kN
Force transfer direction		Compression
Rated characteristic value	(C _{nom})	2 mV/V
Material		Stainless steel
Degree of protection EN 60529		IP67
Encapsulation		Hermetically sealed by welding
Own weight		0.13...0.20 kg
Cable length		3 m
Nominal displacement	(s _{nom})	0.2 mm
Error limits		
Linearity		< 0.020 % of F _{nom}
Hysteresis		< 0.020 % of F _{nom}
Temperature effect on zero signal per 10 °C	(TK ₀)	< 0.030 % of F _{nom}
Temperature effect on characteristic value per 10 °C	(TK _C)	< 0.025 % of F _{nom}
Electrical data		
Input resistance	(R _e)	400 ± 2 Ω
Output resistance	(R _a)	350 ± 2 Ω
Insulation resistance	(R _{is})	> 5 GΩ
Zero signal tolerance	(d ₀)	< 1 % of F _{nom}
Supply voltage	(B _{nom})	1...15 V (typically 10 V)
Operating voltage	(B _G)	1...18 V
Maximum load		
Operating force	(F _G)	120 % of F _{nom}
Force limit	(F _L)	150 % of F _{nom}
Breaking force	(F _B)	> 300 % of F _{nom}
Lateral force limit	(F _Q)	50 % of F _{nom}
Maximum dynamic load		50 % of F _{nom}
Temperature data		
Reference temperature		23 °C
Nominal temperature range	(B _{nom})	-10...40 °C
Operating temperature range		-20...70 °C

Ring force transducers

FC10

Our FC10 ring force sensor measures tension reliably and features easy installation. Through-hole mounting allows the force sensor to be integrated directly into the force flow. It can be used for a variety of industrial, laboratory and monitoring applications. In addition to tension measurement, for example in large bolted joints, and cutting force monitoring in machine tools, the FC10 can be used wherever a large bearing surface is a key factor for easy installation.

Performance features

- Measuring ranges from 10 kN to 1 MN available
- Low overall height
- Easy process integration
- Hermetically sealed by laser welding
- High long-term measurement stability

Options

A version with a built-in measurement amplifier is available

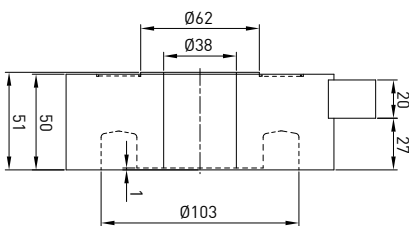
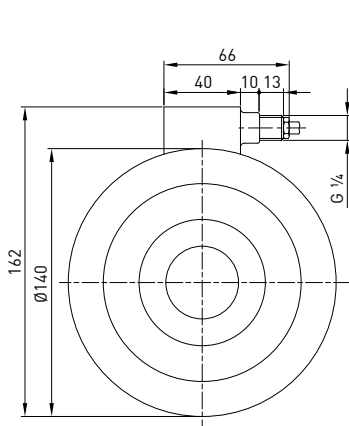

Standard version

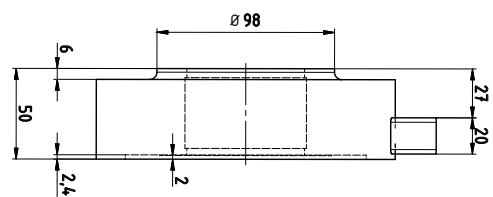
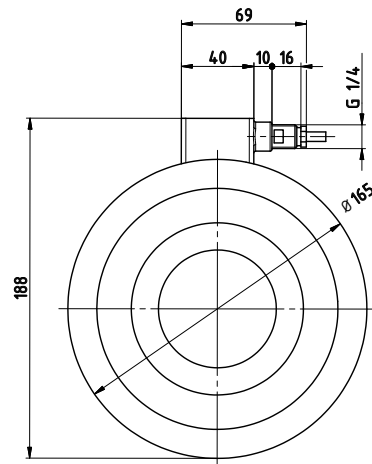

Version with reinforced main body

Technical data

FC10 force sensor		
Rated force	(F _{nom})	10 / 25 / 50 / 100 / 250 / 400 kN
Rated force (for version with reinforced main body)	(F _{nom})	100 / 250 / 400 / 500 / 750 / 1000 kN
Force transfer direction		Compression and tension
Rated characteristic value	(C _{nom})	2 mV/V
Material		Stainless steel
Degree of protection EN 60529		IP67
Encapsulation		Hermetically sealed by welding
Own weight		4.1 / 8.5 kg
Cable length		5 m
Nominal displacement	(s _{nom})	0.17 mm
Error limits		
Linearity		< 0.050 % of F _{nom}
Hysteresis		< 0.100 % of F _{nom}
Temperature effect on zero signal per 10 °C	(TK ₀)	< 0.028 % of F _{nom}
Temperature effect on characteristic value per 10 °C	(TK _C)	< 0.024 % of F _{nom}
Electrical data		
Input resistance	(R _e)	800 ± 20 Ω
Output resistance	(R _a)	705 ± 20 Ω
Insulation resistance	(R _{is})	> 5 GΩ
Zero signal tolerance	(d ₀)	< 0.5 % of F _{nom}
Supply voltage	(B _{nom})	1...15 V (typically 10 V)
Operating voltage	(B _G)	1...18 V
Maximum load		
Operating force	(F _G)	120 % of F _{nom}
Force limit	(F _L)	150 % of F _{nom}
Breaking force	(F _B)	> 300 % of F _{nom}
Lateral force limit	(F _Q)	100 % of F _{nom}
Maximum dynamic load		75 % of F _{nom}
Temperature data		
Reference temperature		23 °C
Nominal temperature range	(B _{nom})	-10...40 °C
Operating temperature range		-20...70 °C

Bending beam load cells

FF1

With its characteristic shape, the FF1 bending beam load cell is among the classics of weighing technology. Easy load transfer and sturdy construction make the FF1 load cell very popular.

In addition to platform and floor scales, this load cell is suitable for all types of scales and for use in dispensing and monitoring processes. The sensor is made entirely from stainless steel – from the determination body to the bellows – and hermetically sealed by welding. With the resulting high IP68 protection class according, the FF1 load cell is suitable for rough industrial processes.

Performance features

- Measuring ranges from 2.5 kg to 200 kg are available
- OIML R60
- Ideally suited for floor and platform scales
- Easy installation
- Hermetically sealed by laser welding
- High long-term measurement stability
- High lateral load limit

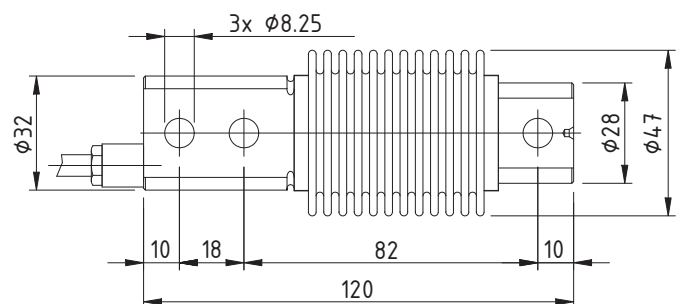
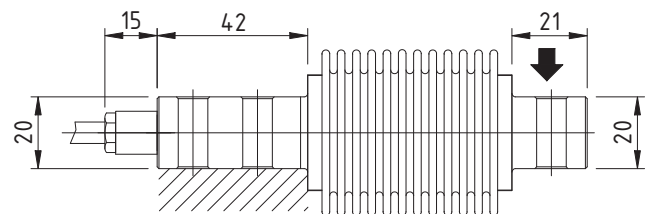

Technical data

FF1 bending beam load cell			
Maximum capacity	(E_{max})	2.5 / 5 / 10 / 25 / 50 / 100 / 200 kg	10 / 25 / 50 / 100 / 200 kg
Load transfer direction		Compression	
OIML R60 accuracy class		C2	C3
Maximum number of load cell intervals	(n_{max})	2000	3000
Rated characteristic value	(C_{nom})	2 mV/V	
Minimum load cell verification interval	(v_{min})	E _{max} /10 000	
Material		Stainless steel	
Degree of protection EN 60529		IP67	
Encapsulation		Hermetically sealed by welding	
Own weight		0.62 kg	
Cable length		5 m	
Nominal displacement		0.4 mm	
Error limits			
Linearity		< 0.026 % of E _{max}	< 0.020 % of E _{max}
Hysteresis		< 0.012 % of E _{max}	< 0.010 % of E _{max}
Reproducibility		< 0.025 % of E _{max}	< 0.015 % of E _{max}
Creep (over 30 min)		< 0.026 % of E _{max}	< 0.012 % of E _{max}
Creep (over 20 and 30 min)		< 0.010 % of E _{max}	< 0.009 % of E _{max}
Temperature influence zero signal for each 10 °C		< 0.025 % of E _{max}	< 0.012 % of E _{max}
Temperature effect on characteristic value per 10 °C		< 0.008 % of E _{max}	< 0.008 % of E _{max}
Electrical data			
Input resistance		420 ± 20 Ω	
Output resistance		350 ± 2 Ω	
Insulation resistance		> 5 GΩ	
Zero signal tolerance		<1% of C _{nom}	
Supply voltage		1...15 V (typically 10 V)	
Operating voltage		1...18 V	
Maximum load			
Operating load		120 % of E _{max}	
Safe load limit	(E_{lim})	150 % of E _{max}	
Breaking load		> 300 % of E _{max}	
Lateral load limit		200 % of E _{max}	
Maximum dynamic load		75 % of E _{max}	
Temperature data			
Reference temperature		23 °C	
Nominal temperature range		-10...40 °C	
Operating temperature range		-20...70 °C	

Shear beam load cells

FFT1

Thanks to their compact design, our shear beam load cells in the FFT1 series can be used for a variety of applications. They are among the most commonly used sensors in weighing equipment and are particularly suitable for dispensing, weighing and platform applications.

Examples of this are large platform scales, silo scales and checkweighers. Due to their high precision, strength and reliability, these load cells are also used in the automated process industry and in quality assurance.

Performance features

- Measuring ranges from 350 kg to 7.5 t are available
- OIML R60, optionally also suitable for certified calibration
- Ideal for floor, container and silo scales
- Compact design
- Hermetically sealed by laser welding
- High long-term measurement stability
- A large number of mechanical mounting aids are available

We offer special installation aids with vibration damping for applications with high vibration levels.

Installation in the process is very easy with our mechanical installation aids made from stainless steel. The installation aids are optimally suited to tanks, silos and stationary funnels.

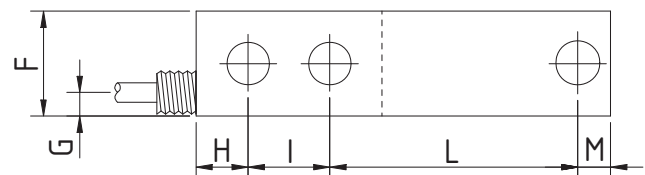
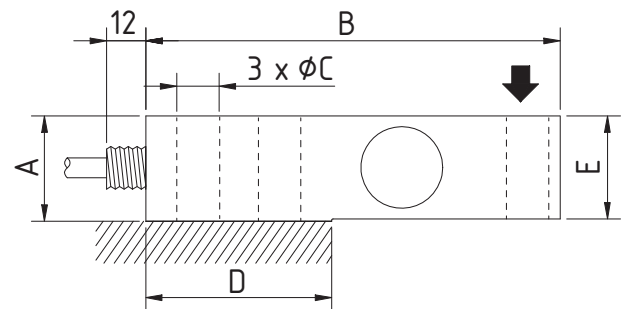

Load	Dimensions [mm]										
	A	B	ØC	D	E	F	G	H	I	L	M
350 / 500 kg	32.2	127	13	57	31.5	32.2	7	16	25	76	10
1 / 2 t	32.2	127	13	57	31.5	32.2	7	16	25	76	10
3 / 5 / 7.5 t	45	180	21	85	45	Ø57	12	18	38.1	105.9	18

Technical data

FFT1 bending beam load cell		
Maximum capacity (E _{max})	350/500 kg	1/2/3/5/7.5 t
Load transfer direction	Compression	
OIML R60 accuracy class	C2	C3
Maximum number of load cell intervals (n _{max})	2000	3000
Rated characteristic value (C _{nom})	2 mV/V	
Minimum load cell verification interval (v _{min})	E _{max} /10 000	
Material	Stainless steel	
Degree of protection EN 60529	IP68	
Encapsulation	Hermetically sealed by welding	
Own weight	1.1 kg	2.6 kg
Cable length	5 m	
Nominal displacement	0.2 to 0.5 mm	
Error limits		
Combined error	< 0.024 % of E _{max}	< 0.020 % of E _{max}
Non-repeatability	< 0.012 % of E _{max}	< 0.010 % of E _{max}
Zero return after 30 min at nominal load	< 0.028 % of E _{max}	< 0.020 % of E _{max}
Creep (over 30 min)	< 0.026 % of E _{max}	< 0.010 % of E _{max}
Creep (over 20 and 30 min)	< 0.012 % of E _{max}	< 0.008 % of E _{max}
Temperature influence zero signal for each 10 °C	< 0.026 % of E _{max}	< 0.014 % of E _{max}
Temperature effect on characteristic value per 10 °C	< 0.020 % of E _{max}	< 0.014 % of E _{max}
Electrical data		
Input resistance	420 ± 20 Ω	
Output resistance	350 ± 2 Ω	
Insulation resistance	> 5 GΩ	
Zero signal tolerance	<1% of C _{nom}	
Supply voltage	1...15 V (typically 10 V)	
Operating voltage	1...18 V	
Maximum load		
Operating load	120 % of E _{max}	
Safe load limit (E _{lim})	150 % of E _{max}	
Breaking load	> 300 % of E _{max}	
Lateral load limit	50 % of E _{max}	
Maximum dynamic load	50 % of E _{max}	
Temperature data		
Reference temperature	23 °C	
Nominal temperature range	-10...40 °C	
Operating temperature range	-20...70 °C	

Sensors for tensile and compressive load

FTCE

The FTCE sensor combines the advantages of cylindrical and S-type load cells, allowing it to provide a large bearing surface. This in turn enables especially good load transfer in the compression direction. A further advantage of this special design, in comparison with conventional S-type load cells, is that the FTCE can achieve very high nominal loads of up to 20 t.

Performance features

- Measuring ranges from 350 kg to 20 t are available
- Hermetically sealed by laser welding
- A large number of mechanical mounting aids are available
- Easy process integration

We supply matching accessories for load cells. In addition to knuckle eyes for tensile load, you receive load transfer heads for compressive load.

Options

- A version with a built-in measurement amplifier is available
- A version with wireless data transfer is available

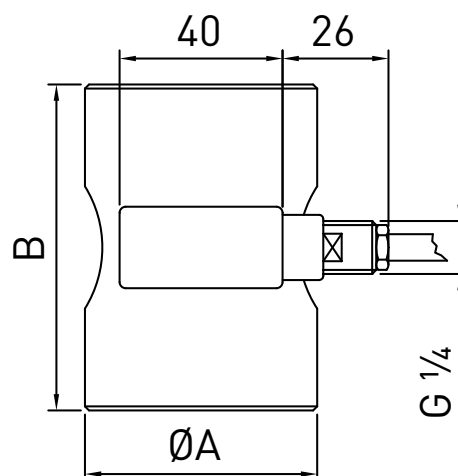
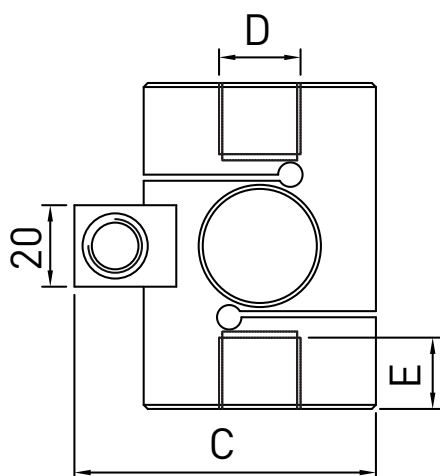

Load	Dimensions [mm]				
	ØA	B	C	D	E
300 / 500 kg	57	80	74.5	M20 x 1.5	17
1 / 2.5 / 5 t	57	80	74.5	M20 x 1.5	17
5 / 7.5 / 10 t	82	110	102	M30 x 2	20
20 t	82	150	102	M42 x 3	30

Technical data

FTCE S-type load cell		
Maximum capacity	(E _{max})	300 / 500 kg
		1 / 2.5 / 5 / 7.5 / 10 / 20 t
Load transfer direction		Compression and tension
Rated characteristic value	(C _{nom})	2 mV/V
Material		Stainless steel
Degree of protection EN 60529		IP67
Encapsulation		Hermetically sealed by welding
Own weight		1.5 to 5 kg
Cable length		5 m
Nominal displacement		0.3 mm
Error limits		
Linearity		< 0.030 % of E _{max}
Hysteresis		< 0.030 % of E _{max}
Reproducibility		< 0.010 % of E _{max}
Temperature influence zero signal for each 10 °C		< 0.030 % of E _{max}
Temperature effect on characteristic value per 10 °C		< 0.011 % of E _{max}
Electrical data		
Input resistance		420 ± 20 Ω
Output resistance		350 ± 2 Ω
Insulation resistance		> 5 GΩ
Zero signal tolerance		< 1 % of C _{nom}
Supply voltage		1...15 V (typically 10 V)
Operating voltage		1...18 V
Maximum load		
Operating load		120 % of E _{max}
Load limit	(E _{lim})	150 % of E _{max}
Breaking load		> 300 % of E _{max}
Lateral load limit		50 % of E _{max}
Maximum dynamic load		50 % of E _{max}
Temperature data		
Reference temperature		23 °C
Nominal temperature range		-10...40 °C
Operating temperature range		-20...70 °C

FTS

The FTS load cell is suitable for measurement of tensile and compressive loads and is well suited for use in weighing equipment and in a variety of industrial applications. For everything from filling and dispensing tasks to applications suitable for certified calibration, our sensor is the perfect solution when precision and easy fitting are required. Other advantages are its good dynamic characteristics and easy load transfer over the two threads.

Performance features

- Measuring ranges from 10 kg to 7.5 t are available
- OIML R60, optionally also suitable for certified calibration
- Hermetically sealed by laser welding
- A large number of mechanical mounting aids are available
- Easy process integration
- A version with a built-in measurement amplifier is available
- Knuckle eyes for load transfer available as accessories



Options

- Special material 1.4542

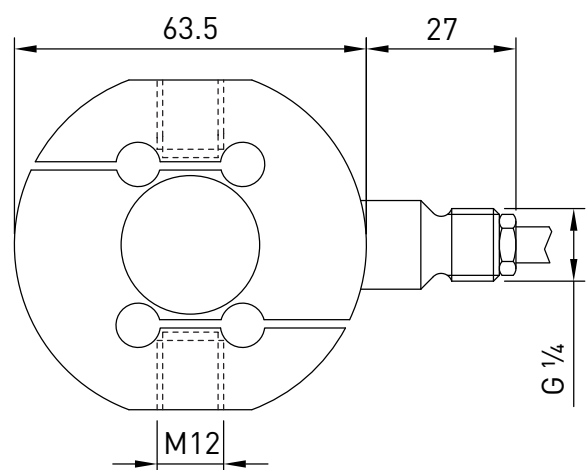
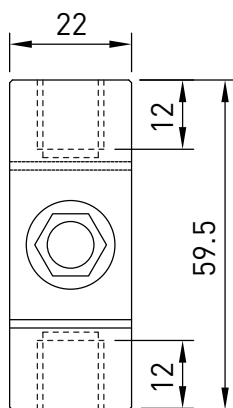

Load	Dimensions [mm]				
	ØA	B	C	D	E
10 / 25 / 50 / 100 / 200 / 300 / 500 kg	63.5	59.5	22	M12 x 1.75	12
500 kg / 1 / 2 t	82	78	30	M16 x 2	20
2.5 t	82	78	30	M20 x 1.5	20
5 / 7.5 t	102	90	45	M24 x 2	21.5

Technical data

FTS S-type load cell			
Maximum capacity (E _{max})	10 / 25 / 50 / 100 / 300 / 500 kg		500 kg
	1 / 2 / 2.5 / 5 / 7.5 t		1 / 2 / 2.5 t
Load transfer direction	Compression and tension		
OIML R60 accuracy class	C2	C3	C4
Maximum number of load cell intervals (n _{max})	2000	3000	4000
Rated characteristic value (C _{nom})	2 mV/V		
Minimum load cell verification interval (v _{min})	E _{max} /10 000		E _{max} /15000
Material	Stainless steel		
Degree of protection EN 60529	IP68 (IP65 with E _{max} 10 / 25 / 50 kg)		
Encapsulation	Welded hermetically tight / silicone-sealed (for E _{max} 10 / 25 / 50 kg)		
Own weight	0.6 bis 2.6 kg		
Cable length	5 m		
Nominal displacement	0.2 mm		
Error limits			
Combined error	< 0.023 % of E _{max}	< 0.018 % of E _{max}	< 0.015 % of E _{max}
Non-repeatability	< 0.015 % of E _{max}	< 0.010 % of E _{max}	< 0.010 % of E _{max}
Zero return after 30 min at nominal load	< 0.025 % of E _{max}	< 0.015 % of E _{max}	< 0.010 % of E _{max}
Creep (over 30 min)	< 0.025 % of E _{max}	< 0.015 % of E _{max}	< 0.015 % of E _{max}
Creep (over 20 and 30 min)	< 0.005 % of E _{max}	< 0.005 % of E _{max}	< 0.003 % of E _{max}
Temperature influence zero signal for each 10 °C	< 0.028 % of E _{max}	< 0.010 % of E _{max}	< 0.008 % of E _{max}
Temperature effect on characteristic value per 10 °C	< 0.012 % of E _{max}	< 0.010 % of E _{max}	< 0.008 % of E _{max}
Electrical data			
Input resistance	420 ± 20 Ω		
Output resistance	350 ± 2 Ω		
Insulation resistance	> 5 GΩ		
Zero signal tolerance	<1 % of C _{nom}		
Supply voltage	1...15 V (typically 10 V)		
Operating voltage	1...18 V		
Maximum load			
Operating load	120 % of E _{max}		
Load limit (E _{lim})	150 % of E _{max}		
Breaking load	> 300 % of E _{max}		
Lateral load limit	50 % of E _{max}		
Maximum dynamic load	50 % of E _{max}		
Temperature data			
Reference temperature	23 °C		
Nominal temperature range	-10...40 °C		
Operating temperature range	-20...70 °C		

FTCA

Our new FCTA S-type load cell has a variety of uses and is nevertheless inexpensive. In addition to its ability to measure both compression and tension, the sensor is easy to use.

These especially small load cells come to the fore in low load ranges. The load is simply transferred to the load cell over the two threads. In spite of its small design, the sensor achieves a high accuracy of $< \pm 0.030\%$ for linearity and hysteresis.

Performance features

- Measuring ranges from 1 to 50 kg are available
- Excellent value for money
- Overload protection for nominal loads < 10 kg
- Compact design
- Mechanical overload protection available
- A large number of mechanical mounting aids are available

We supply matching accessories for the FTCA. In addition to knuckle eyes for tensile load, you receive mounting plates and load transfer heads for compressive load.

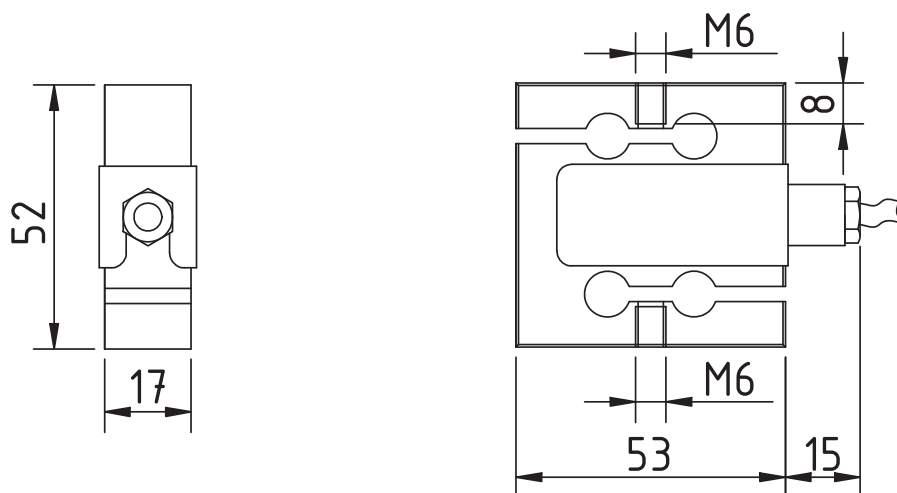
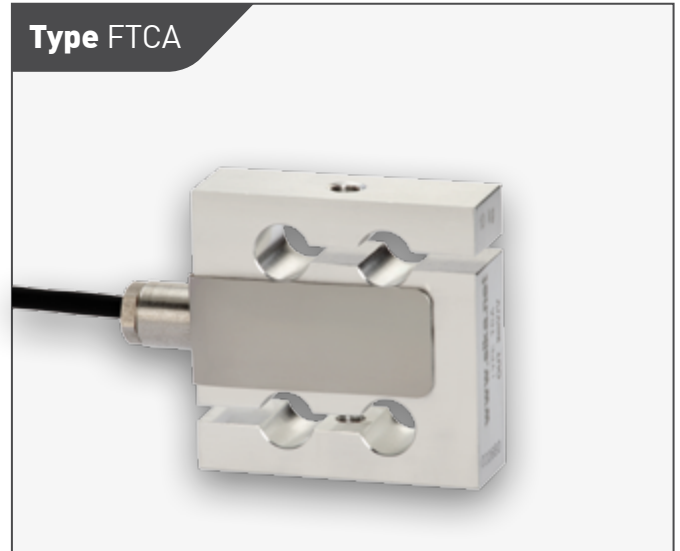

Technical data

FTCA S-type load cell		
Maximum capacity	(E_{max})	1 / 2 / 5 / 10 / 25 / 50 kg
Load transfer direction		Compression and tension
Rated characteristic value	(C_{nom})	2 mV/V
Material		Aluminium
Degree of protection EN 60529		IP20
Own weight		0.3 kg
Cable length		3 m
Nominal displacement		0.3 mm
Error limits		
Linearity		< 0.030 % of E _{max}
Hysteresis		< 0.030 % of E _{max}
Reproducibility		< 0.010 % of E _{max}
Temperature influence zero signal for each 10 °C		< 0.025 % of E _{max}
Temperature effect on characteristic value per 10 °C		< 0.021 % of E _{max}
Electrical data		
Input resistance		440 ± 20 Ω
Output resistance		350 ± 3 Ω
Insulation resistance		> 5 GΩ
Zero signal tolerance		<1% of C _{nom}
Supply voltage		1...15 V (typically 10 V)
Operating voltage		1...18 V
Maximum load		
Operating load		120 % of E _{max}
Safe load limit	(E_{lim})	150 % of E _{max}
Breaking load		> 300 % of E _{max}
Lateral load limit		50 % of E _{max}
Maximum dynamic load		50 % of E _{max}
Temperature data		
Reference temperature		23 °C
Nominal temperature range		-10...40 °C
Operating temperature range		-20...70 °C

Sensors for tensile loads

FD200

Our FD200 heavy-load cell is suitable for measuring large tensile forces. We provide five different versions with nominal loads from 20 to 100 t.

The 60 mm or 73 mm diameter connector bores provide attachment for connector bolts in fork bearings. Our FD200 may be used with quality shackles as connectors for measuring large forces on cables. We provide the appropriate shackles as accessories on request.

Performance features

- Measurement ranges available from 20 to 100 t
- Laser-welded for complete insulation
- Easy to integrate into your application
- High long-term measurement stability
- A large number of mechanical mounting aids are available

Options

- Version available with cable-free measurement signal transmission
- Connection cable 5 or 10 m MIL connector
- Degree of protection IP67 available with fixed cable connection
- Equipped with shackles for measuring forces on cables

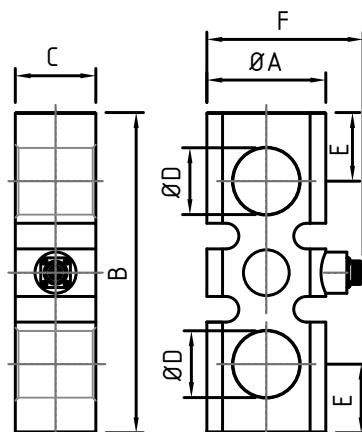

Load	Dimensions [mm]					
	ØA	B	C	ØD	E	F
20 t / 30 t	102	280	78	60	50	Approx. 140
50 t / 75 t / 100t	130	350	88	73	75	Approx. 171

Technical data

Heavy-load cell FD200			
Maximum capacity	(E_{max})	20 / 30 t	50 / 75 / 100 t
Load transfer direction		Tension	
Rated characteristic value	(C_{nom})	2 mV/V	
Material		Stainless steel	
Degree of protection EN 60529		IP65 (with connector), IP67 (with cable)	
Encapsulation		Hermetically sealed by welding	
Own weight		10 kg	19 kg
Connection		MIL-C-5015 7-pin connector / cable	
Error limits			
Combined error		< 0.100 % of E _{max}	
Linearity		< 0.100 % of E _{max}	
Hysteresis		< 0.100 % of E _{max}	
Temperature influence zero signal for each 10 °C		< 0.028 % of E _{max}	
Temperature effect on characteristic value per 10 °C		< 0.008 % of E _{max}	
Electrical data			
Input resistance		420 ± 20 Ω	
Output resistance		350 ± 2 Ω	
Insulation resistance		> 5 GΩ	
Supply voltage		1...15 V (typically 10 V)	
Operating voltage		1...18 V	
Maximum load			
Operating load		120 % of E _{max}	
Load limit	(E_{lim})	150 % of E _{max}	
Breaking load		> 200 % of E _{max}	
Lateral load limit		50 % of E _{max}	
Temperature data			
Reference temperature		23 °C	
Nominal temperature range		-10...40 °C	
Operating temperature range		-20...70 °C	

Sensor for compression load

FC2S

Robust and available in a wide variety of nominal loads: the SIKA FC2S load cell. The sensor is suitable for measuring static and dynamic compressive loads and is versatile in use thanks to a wide range of mechanical accessories. They enable good load transfer, even under difficult conditions.

We supply a large number of measuring ranges, starting with nominal loads of 100 kg or more and extending to 2000 times this smallest version with 200 t. Thanks to their flat design, small space requirements and small nominal displacement, our load cells are attractive for a wealth of applications.

Performance features

- Measuring ranges from 100 kg to 200 t are available
- OIML R60
- Low overall height
- Hermetically sealed by laser welding
- High long-term measurement stability
- A large number of mechanical mounting aids are available



Options

- A version with a built-in measurement amplifier is available
- A version with wireless measurement data transfer is available

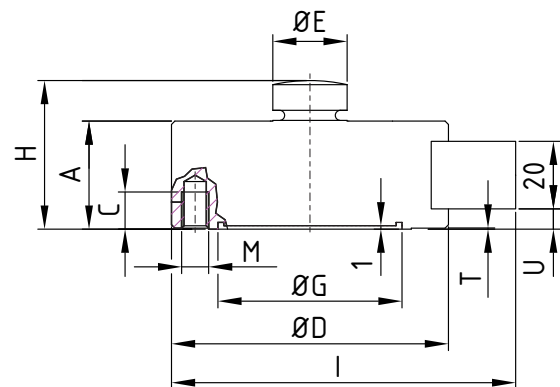
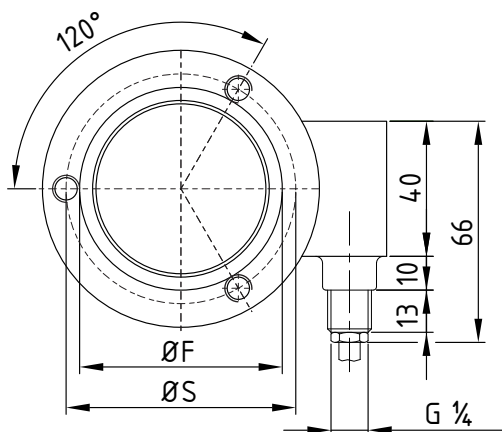

Load	Dimensions [mm]												
	A	C	ØD	ØE	ØF	ØG	H	I	M	n °M	S	T	U
100 / 250 / 500 kg	32	11	82	22	68	52.3	44	102	M8	3	60	0.3	6
1 / 2.5 / 5 / 7.5 / 10 t	32	11	82	22	68	52.3	44	102	M8	3	60	0.3	6
20 / 30 t	50	12	126	35	90	77.3	64	148	M8	3	100	0.5	15
50 / 75 / 100 t	60	20	165	60	130	92.3	80	188	M16	4	115	1	17
150 / 200 t	80	20	200	80	152	107	110	223	M16	4	134	1	23

Technical data

FC2S compression load cell			
Maximum capacity (E _{max})	100 / 250 / 500 kg		
	1 / 2.5 / 5 / 7.5 / 10 / 20 / 30 / 50 / 75 / 100 / 150 / 200 t		
Load transfer direction	Compression		
OIML R60 accuracy class	C1	C2	C3
Maximum number of load cell intervals (n _{max})	1000	2000	3000
Rated characteristic value (C _{nom})	2 mV/V		
Minimum load cell verification interval (v _{min})	E _{max} /10 000		
Material	Stainless steel		
Degree of protection EN 60529	IP68		
Encapsulation	Hermetically sealed by welding		
Own weight	1.3 to 18.2 kg		
Cable length	5 m		
Nominal displacement	0.06 to 0.36 mm		
Error limits			
Combined error	< 0.045 % of E _{max}	< 0.023 % of E _{max}	< 0.018 % of E _{max}
Non-repeatability	< 0.015 % of E _{max}	< 0.010 % of E _{max}	< 0.008 % of E _{max}
Zero return after 30 min at nominal load	< 0.036 % of E _{max}	< 0.026 % of E _{max}	< 0.016 % of E _{max}
Creep (over 30 min)	< 0.035 % of E _{max}	< 0.028 % of E _{max}	< 0.022 % of E _{max}
Creep (over 20 and 30 min)	< 0.010 % of E _{max}	< 0.008 % of E _{max}	< 0.005 % of E _{max}
Temperature influence zero signal for each 10 °C	< 0.030 % of E _{max}	< 0.024 % of E _{max}	< 0.020 % of E _{max}
Temperature effect on characteristic value per 10 °C	< 0.030 % of E _{max}	< 0.017 % of E _{max}	< 0.010 % of E _{max}
Electrical data			
Input resistance	700 ± 2 Ω		
Output resistance	700 ± 2 Ω		
Insulation resistance	> 5 GΩ		
Zero signal tolerance	< 1 % of C _{nom}		
Supply voltage	1...15 V (typically 10 V)		
Operating voltage	1...18 V		
Maximum load			
Operating load	120 % of E _{max}		
Safe load limit (E _{lim})	150 % of E _{max}		
Breaking load	> 300 % of E _{max}		
Lateral load limit	50 % of E _{max}		
Maximum dynamic load	50 % of E _{max}		
Temperature data			
Reference temperature	23 °C		
Nominal temperature range	-10...40 °C		
Operating temperature range	-20...70 °C		

FCBS

Our sturdy FCBS compressive load cell is available with a wide variety of nominal loads from 250 kg to 100 t. The sensor is suitable for measuring static and dynamic compressive loads and is versatile in use thanks to a wide range of mechanical accessories.

Thanks to the wide variety of installation aids, good load transfer is possible even under difficult conditions. The flat shape, low space requirements and small nominal displacement make the FCBS load cell attractive for numerous applications. In particular, this sensor features low cost combined with high quality.

Performance features

- Measuring ranges from 250 kg to 100 t are available
- Excellent value for money
- Low overall height
- Hermetically sealed by laser welding
- High long-term measurement stability
- A large number of mechanical mounting aids are available

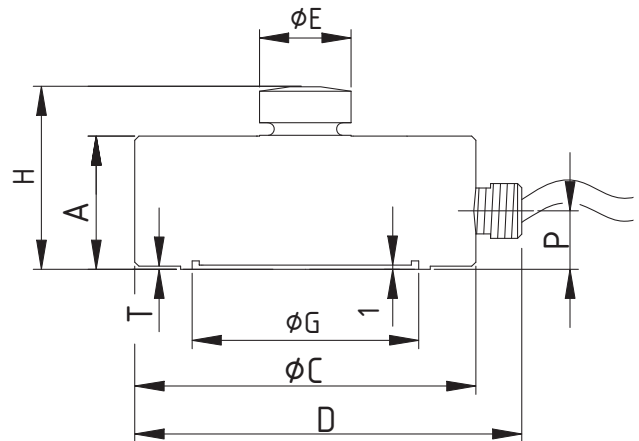
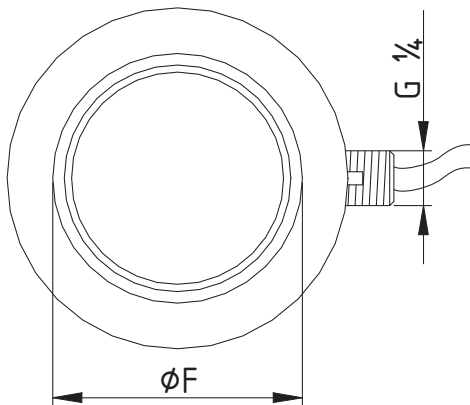

Load	Dimensions [mm]								
	A	ØC	D	ØE	ØF	ØG	H	T	P
250 / 500 kg	32	82	93	22	60	52.3	44	0.3	14
1 / 2.5 / 5 / 7.5 / 10 t	32	82	93	22	60	52.3	44	0.3	14
15 t	35	100	115	28	70	57.3	48	0.3	14
20 / 30 t	40	126	137	35	92	77.3	54	0.5	14
50 / 75 / 100 t	60	165	180	60	115	92.3	80	1	28

Technical data

FCBS compression load cell	
Maximum capacity	(E_{max}) 250 / 500 kg
	1 / 2.5 / 5 / 7.5 / 10 / 15 / 20 / 30 / 50 / 75 / 100 t
Load transfer direction	Compression
Rated characteristic value	(C_{nom}) 2 mV/V
Material	Stainless steel
Degree of protection EN 60529	IP68
Encapsulation	Hermetically sealed by welding
Own weight	1.2 to 9.4 kg
Cable length	5 m
Nominal displacement	0.06 to 0.23 mm
Error limits	
Combined error	< 0.030 % of E _{max}
Non-repeatability	< 0.010 % of E _{max}
Zero return after 30 min at nominal load	< 0.030 % of E _{max}
Creep (over 30 min)	< 0.030 % of E _{max}
Creep (over 20 and 30 min)	< 0.010 % of E _{max}
Temperature influence zero signal for each 10 °C	< 0.050 % of E _{max}
Temperature effect on characteristic value per 10 °C	< 0.030 % of E _{max}
Electrical data	
Input resistance	700 ± 3 Ω
Output resistance	700 ± 3 Ω
Insulation resistance	> 5 GΩ
Zero signal tolerance	< 1 % of C _{nom}
Supply voltage	1...15 V (typically 10 V)
Operating voltage	1...18 V
Maximum load	
Operating load	120 % of E _{max}
Safe load limit	(E_{lim}) 150 % of E _{max}
Breaking load	> 300 % of E _{max}
Lateral load limit	50 % of E _{max}
Maximum dynamic load	50 % of E _{max}
Temperature data	
Reference temperature	23 °C
Nominal temperature range	-10...40 °C
Operating temperature range	-20...70 °C

Platform load cells

FFT6

The FFT6 platform load cell is not only very popular in scale construction, but also in industrial processes. This all-round load cell is at home anywhere scales are built – whether platform, dispensing, sack filling, conveyor or other types of scales. These load cells are stalwarts in industrial processes, for example in the paper industry and steel construction.

A special feature is that they can be mounted very easily under a platform, without the need for additional adjustment. Using the FFT6 is remarkably easy – simply mount a plate on the load cell to serve as a weighing platform and you have a fully functional weighing unit.

The parallelogram shape of the measuring element makes it insensitive to torques. This allows scales with platform sizes up to around 400 x 400 mm to be implemented using a single load cell.



Performance features

- Maximum capacity of 5 to 100 kg are available
- OIML R60
- Hermetically sealed by laser welding
- Platform sizes up to approximately 400 x 400 mm possible with a single load cell
- High long-term measurement stability
- Screw mounting surfaces with threaded holes

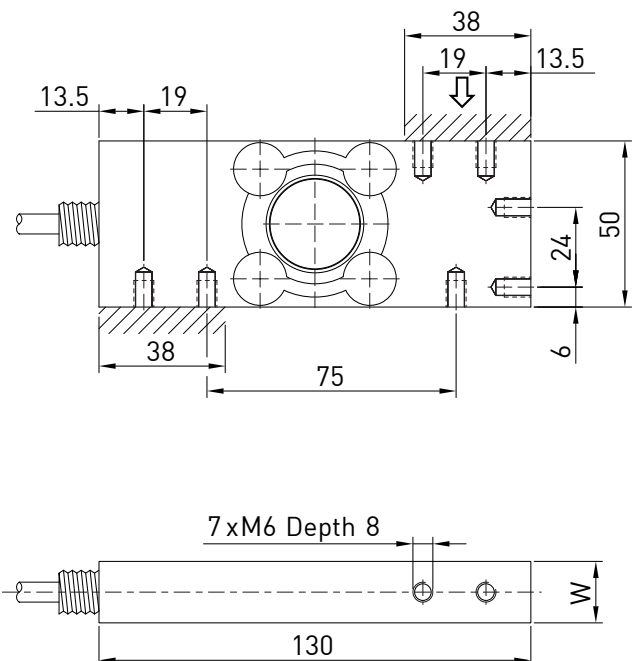

Load	Dimensions [mm]
	W
5 / 10 / 20 / 30 kg	18.5
50 / 100 kg	24

Technical data

FFT6 platform load cell		
Maximum capacity	(E _{max})	5 / 10 / 20 / 30 / 50 / 100 kg
Load transfer direction		Compression
OIML R60 accuracy class		C2
Maximum number of load cell intervals	(n _{max})	2000
Rated characteristic value	(C _{nom})	2 mV/V
Minimum load cell verification interval	(v _{min})	E _{max} /10 000
Material		Stainless steel
Degree of protection EN 60529		IP67
Encapsulation		Hermetically sealed by welding
Own weight		1 kg
Cable length		5 m
Nominal displacement		0.4 mm
Error limits		
Combined error		< 0.028 % of E _{max}
Zero return after 30 min at nominal load		< 0.030 % of E _{max}
Creep (over 20 and 30 min)		< 0.009 % of E _{max}
Temperature influence zero signal for each 10 °C		< 0.025 % of E _{max}
Temperature effect on characteristic value per 10 °C		< 0.010 % of E _{max}
Electrical data		
Input resistance		420 ± 20 Ω
Output resistance		350 ± 2 Ω
Insulation resistance		> 5 GΩ
Zero signal tolerance		< 1 % of C _{nom}
Supply voltage		1...15 V (typically 10 V)
Operating voltage		1... 18 V
Maximum load		
Operating load		120 % of E _{max}
Load limit	(E _{lim})	150 % of E _{max}
Breaking load		> 300 % of E _{max}
Lateral load limit		200 % of E _{max}
Maximum dynamic load		75 % of E _{max}
Temperature data		
Reference temperature		23 °C
Nominal temperature range		-10...40 °C
Operating temperature range		-20...70 °C

Overview of force sensors and load cells

Model	Sensor		Direction		Available nominal loads													
	Load cell	Force sensor	Com-pression	Tension	0 kg / 0 N	100 kg / 1 kN	200 kg / 2 kN	500 kg / 5 kN	1 t / 10 kN	2 t / 20 kN	5 t / 50 kN	10 t / 100 kN	20 t / 200 kN	50 t / 500 kN	100 t / 1 MN	200 t / 2 MN	500 t / 5 MN	
Low profile force sensor																		
FTC4		✓	✓	✓														
Force sensors for compression and tensile load																		
FTCETM		✓	✓	✓														
FTSTM		✓	✓	✓														
Force sensors for compression																		
FC8S		✓	✓															
FCM		✓	✓															
Ring force transducers																		
FC10		✓	✓	✓														
Bending and shear beam load cells																		
FF1	✓		✓															
FFT1	✓		✓															
Load cells for compression and tensile load																		
FTCE	✓		✓	✓														
FTS	✓		✓	✓														
FTCA	✓		✓	✓														
Load cells for tensile load																		
FD200	✓			✓														
Load cells for compression																		
FC2S	✓		✓															
FCBS	✓		✓															
Platform load cells																		
FFT6	✓		✓															

Accuracy											General data				
ISO 376			OIML R60				Linearity				Material stainless steel	Laser welded	Integrated measurement amplifier possible	Approvable version available	Wireless data transmission possible
00	0.5	1	C1	C2	C3	C4	0.03 %	0.05 %	0.1 %						
		✓						✓			✓	✓	✓		✓
✓	✓	✓									✓	✓			
✓	✓	✓									✓	✓			
	✓	✓									✓	✓			
									✓	✓	✓	✓			
				✓	✓						✓	✓			
				✓	✓						✓	✓		✓	
								✓			✓	✓			✓
										✓	✓	✓			
											✓	✓			✓
											✓	✓			
				✓	✓	✓		✓			✓	✓			✓
								✓			✓	✓			
				✓							✓	✓			



Measurement amplifier

SIKA force measurement systems generally consist of a combination of one or more sensors and a measurement amplifier. The sensors contain four internal strain gauges, each connected in a full-bridge circuit, as well as a compensative circuit. The electrical circuit conforms to the principle of the Wheatstone bridge.

For this reason, all of the SIKA measurement amplifiers shown in this chapter are equipped with a measurement bridge input. Its function is to provide the sensor with a supply voltage and to amplify the output signal.

The supply voltage is generated by the measurement amplifier either in a highly stable DC voltage generator or in an AC voltage generator. In this case, the amplitude and frequency of this voltage are highly stabilised. The quality of this supply voltage is extremely important as it directly influences the accuracy and stability of the measurement signal.

When the sensor is subjected to a force or a weight, it supplies a voltage in proportion to the force or the weight. The amount of voltage is derived from the characteristic value of the sensor and of the supply voltage. For example, a sensor with a nominal characteristic value of 2 mV / V and a supply voltage of 10 V delivers an input signal of 20 mV to the measurement amplifier at the rated force.

The measurement amplifier conditions the millivolt signal and converts it into a signal suitable for further processing. From a technical perspective, signal processing is realised in different ways depending on the amplifier design: The majority of our measurement amplifiers make use of digital signal conditioning. This offers numerous technical benefits with regard to the accuracy of the chain of measurements: There are no errors due to non-ideal structural elements (tolerances, synchronisation etc.), no drift or hysteresis errors, an absolutely stable filter characteristic. No adjustment is required and sensors can be configured and installed quickly and easily.

To provide the optimum solution for as many applications as possible and for every customer requirement, we offer a broad selection of measurement amplifiers.

These measurement amplifiers are described on the following pages:

- Analogue measurement amplifiers
- digital measurement amplifiers
- digital measurement amplifiers with display
- mobile compact display units

We offer our digital measurement amplifiers in numerous different versions:

- As a box or version for top-hat rail mounting for PC-based signal processing.
- As built-in devices with a front bezel and integrated display for direct indication. These devices are not only equipped with a display for the measured values, but also with extensive functions and options for further signal processing.
- Our USB measurement amplifier is not only technically extremely comprehensive, but also easy to install and operate. The integrated software allows sensors to be configured and the measured values to be recorded. As well as the mV / V signals from the force sensors and load cells, signals from other sensors can also be processed (analogue standard signals, impulses, torque, temperature, distance).
- Our compact display units are particularly popular for mobile applications. These units are battery-powered and feature an integrated display along with configuration options.
- For precision measurements, such as those carried out using our force calibration systems or in calibration laboratories, we offer a high-precision measurement amplifier.

We also supply analogue measurement amplifiers, which convert the sensor signal into an analogue standard signal. This can be further processed by a PLC, for example. Analogue measurement amplifiers enable quick and easy configuration of the sensors.

For virtually all measurement amplifiers, we offer additional solutions that allow the devices to be connected to a PC and measured values to be processed there.



Analogue measurement amplifier

FTA4 / 2

The FTA4 / 2 analogue measurement amplifier enables simple and economical connection of your force sensors or load cells to a PLC or a PC with measuring interface card. An integrated analogue filter also enables adaptation to individual conditions, e. g. better readout in applications subject to vibration.

Performance features

- Aluminium housing (IP65) or version for top-hat rail mounting
- Supply voltage 24 V DC
- Strain gauge input 2 mV / V
- 4-wire connection
- Up to 4 or 8 sensors can be connected
- Accuracy 0.02 %
- Analogue output 4...20 mA

The zero and full scale values of the measuring range are set in the amplifier using DIP switches and potentiometers. The FTA4 / 2 measurement amplifier is available in two versions: in a sturdy sealed aluminium enclosure with IP65 degree of protection according to EN 60529, or in a form suitable for mounting directly on a top-hat rail in an electrical cabinet.

Options

- Alternative input voltage range: 1 mV / V or 3 mV / V
- Alternative output signals: 0...20 mA, ± 5 V or ± 10 V
- 5 instead of 2 cable glands

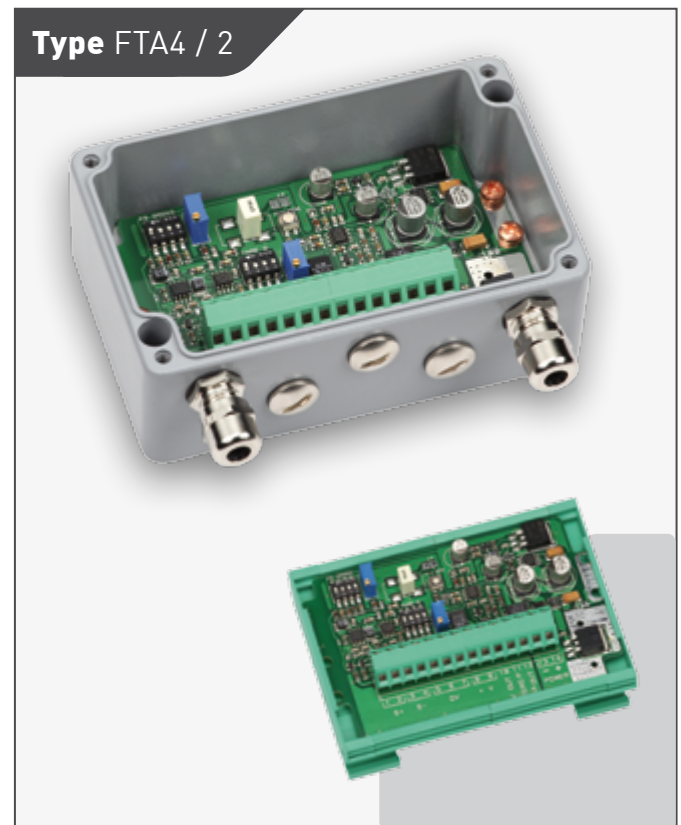

Technical data

Analogue measurement amplifier FTA4 / 2	
Accuracy	< 0.02%
Linearity error	< 0.02%
Strain gauge input	2 mV/V
Input resistance	10 ¹⁰ Ω
Number of sensors that can be connected	4 (350 Ω) or 8 (700 Ω)
Bridge supply voltage	10 V DC ±4 %
Connection type	4-wire
Degree of protection EN 60529	IP65 (only with aluminium enclosure)
Own weight	0.6 kg (aluminium enclosure) / 0.2 kg (top-hat rail mounting)
Supply voltage	
Operating voltage	24 V DC (16–26 VDC)
Current draw	200 mA
External fuse	500 mA / 250 V / fast-acting
Analogue output	
Output signal	4...20 mA
Load resistance range	470 Ω to 3 kΩ
Output response time	
→ Standard mode (J4 closed, adjustable via potentiometer)	60...400 msec
→ Fast mode (J4 open)	1 msec
Measuring range full scale value	
→ Coarse setting with DIP switches	5...30 mV
→ Fine adjustment with potentiometer	±10 %
Zero adjustment	
→ Coarse setting with DIP switches	±70 %
→ Fine adjustment with potentiometer	±10 %
Temperature data	
Nominal temperature range	0...50 °C
Operating temperature range	0...70 °C
Temperature deviation (10 °C)	
→ Measuring range zero point	< 0.01 %
→ Measuring range full scale value	< 0.01 %
Dimensions	
Version in aluminium enclosure	125 x 80 x 58 mm (L x W x H)
Version for top-hat rail mounting	114 x 82 x 42 mm (L x W x H)

Digital measurement amplifier

FTA5F

Our FTA5F digital measurement amplifier enables the easy and economical connection of your force sensors or load cells to a device with a serial interface, such as a PLC or a PC. The measuring range scale, decimal point and resolution are programmed at command level via the serial interface. An integrated digital filter enables adaptation to individual conditions – such as better readout in applications subject to vibration.

In operation, readings can be retrieved individually or the device can be put into continuous data transmission mode. In this mode, the FTA5F constantly sends measurement data at a configurable repetition rate.

Performance features

- Aluminium enclosure (IP65) or version for top-hat rail mounting
- Supply voltage 24 V DC
- Selectable strain gauge input sensitivity 1/2/3 mV/V
- Supports 4-wire and 6-wire connection
- Up to 4 or 8 sensors can be connected
- Accuracy < 0.01 %
- RS 232C / RS 485 serial port

The FTA5F measurement amplifier is available in two versions: in a sturdy sealed aluminium enclosure with IP65 degree of protection according to EN 60529, or in a form suitable for mounting directly on a top-hat rail in an electrical cabinet.

Options

- Modbus RTU protocol
- 5 instead of 2 cable glands

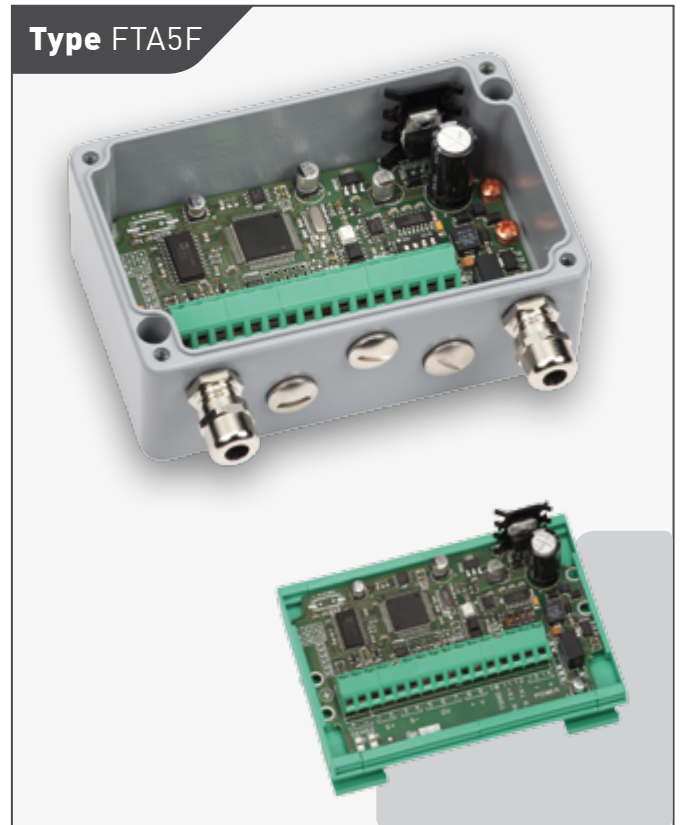

Technical data

Digital measurement amplifier FTA5F	
Accuracy	< 0.01 %
Linearity error	< 0.01 %
Resolution (2 mV / V)	±200 000 steps
Internal resolution	±1 000 000 steps
Sampling rate	Max. 300 Hz (filter = 0)
Strain gauge input	Selectable 1 mV / V, 2 mV / V or 3 mV / V
Input resistance	10 ¹⁰ Ω
Number of sensors that can be connected	4 (350 Ω) or 8 (700 Ω)
Bridge supply voltage	5 V DC ±4 %
Connection type	4-wire and 6-wire
Degree of protection EN 60529	IP65 (only with aluminium enclosure)
Own weight	0.6 kg (aluminium enclosure) / 0.2 kg (top-hat rail mounting)
Supply voltage	
Operating voltage	24 V DC (11...26 V DC)
Current draw	180 mA
External fuse	315 mA / 250 V / fast-acting
Output signal	
Serial port	Selectable RS 232C / RS 485
Baud rate	4800, 9600, 19 200, 38 400, 115 200
Temperature data	
Nominal temperature range	0...50 °C
Operating temperature range	0...70 °C
Temperature deviation (10 °C)	
→ Measuring range zero point	< 0.01 %
→ Measuring range full scale value	< 0.01 %
Dimensions	
Version in aluminium enclosure	125 x 80 x 58 mm (L x W x H)
Version for top-hat rail mounting	114 x 82 x 60 mm (L x W x H)

FMP1

The FMP1 measurement amplifier is a versatile digital instrument for direct indication of force or weight. Various additional functions enable balancing out tare weights and measuring peak forces or weights.

Performance features

- Built-in device with front bezel
- 4-digit digital display
- Supply voltage 230 V AC
- Strain gauge input 2 mV / V
- 4-wire connection
- Up to 4 or 8 sensors can be connected
- Accuracy < 0.05 %
- 2 switching points with relay outputs
- Peak-hold function

Versions are available for measuring in units of kN, kg or t. Readings are shown on a 4-digit digital display.

Our measurement amplifier uses an internal A / D converter with $\pm 19\,999$ steps; the standard 2 mV / V Signal is therefore resolved into ± 9999 steps. The maximum sampling rate is 300 Hz. An integrated digital filter enables adaptation to individual conditions, e. g. better readout in applications subject to vibration.

The device has two programmable switching points as standard, which can be used to switch floating relay contacts. The switching hysteresis can be programmed for each switching point.

Type FMP1



Options

- Other strain gauge input signals: 1 mV / V or 3 mV / V
- Alternatively, other standard input signals: ± 5 V, ± 10 V, 0...20 mA, 4...20 mA
- Analogue output: 0...20 mA, 4...20 mA, 0...5 V or 0...10 V
- Other supply voltage: 115 V AC / 50...60 Hz or 24 V DC (15...28 V DC)

Technical data

Digital measurement amplifier FMP1	
Accuracy	< 0.05 %
Linearity error	< 0.05 %
Resolution (2 mV / V)	±9999 steps
Internal resolution	±19 999 steps
Sampling rate	Max. 300 Hz (filter = 0)
Strain gauge input	2 mV/V
Number of sensors that can be connected	4 (350 Ω) or 8 (700 Ω)
Bridge supply voltage	5 V DC ±3 %
Connection type	4-wire
Own weight	0.5 kg
Supply voltage	
Operating voltage	230 V AC ±10%, 50...60 Hz
Power consumption	5 VA
Digital display	
LED display	7 segments, red, 4-digit
Segment height	13 mm
Switching points and relay outputs	
Switching points	2 (for driving one relay each)
Contact rating	115 V AC 0.2 A or 48 V DC 0.2 A (resistive load)
Temperature data	
Nominal temperature range	0...50 °C
Operating temperature range	-10...50 °C
Temperature deviation (10 °C)	
→ Measuring range zero point	< 0.01 %
→ Measuring range full scale value	< 0.01 %
Dimensions	
Overall	153 x 96 x 48 mm (L x W x H)
Dimensions for front panel cutout	91.5 x 44.5 (W x H)

FMP2E

Our FMP2E digital measurement amplifier features high accuracy and a large range of functions. The instrument is used for the direct indication of forces or weights and is available in several versions for units of kN, kg or t. The integrated digital filter enables adaptation to individual conditions, such as for better readout in applications subject to vibration.

Various additional functions enable balancing out tare weights and measuring peak forces or weights. Another advantage is that the buttons on the front panel can be password-protected.

Performance features

- Built-in device with front bezel
- 6-digit digital display
- Supply voltage 230 V AC
- Strain gauge input 2 mV / V
- Supports 4-wire and 6-wire connection
- Up to 6 or 12 sensors can be connected
- Accuracy < 0.01 %
- 4 switching points with relay outputs
- Peak-hold function

Our digital measurement amplifier uses an internal A / D converter with $\pm 500\,000$ steps; the standard 2 mV / V Signal is resolved into $\pm 50\,000$ steps. The maximum sampling rate is 160 Hz. The device has four user-programmable switching points as standard, which can be used to switch floating relay contacts. The switching hysteresis can be programmed for each switching point.

On the output side the FMP2E has an interface module with a protocol or output signal that can be selected by the user when ordering.

Type FMP2E



Options

- Other strain gauge input signals: 1 mV / V or 3 mV / V
- Alternatively, other standard input signals: $\pm 5\text{ V}$, $\pm 10\text{ V}$, 0...20 mA, 4...20 mA
- Output interface: selection of one of the following Output signals and/or interfaces
 - analogue output:
 - 0...20 mA / 4...20 mA / $\pm 5\text{ V}$ or $\pm 10\text{ V}$
 - RS 232C
 - RS 485
 - USB 2.0
 - Modbus
- Other supply voltage: 115 V AC / 50...60 Hz or 24 V DC $\pm 10\%$

Technical data

Digital measurement amplifier FMP2E	
Accuracy	< 0.01 %
Linearity error	< 0.01 %
Resolution (2 mV / V)	±50 000 steps
Internal resolution	±500 000 steps
Sampling rate	Max. 160 Hz (filter = 0)
Strain gauge input	2 mV/V
Number of sensors that can be connected	6 (350 Ω) or 12 (700 Ω)
Bridge supply voltage	5 V DC ±3 %
Connection type	4-wire or 6-wire
Own weight	0.9 kg
Supply voltage	
Operating voltage	230 V AC ±10%, 50...60 Hz
Power consumption	10 VA
Digital display	
LED display	7 segments, red, 6-digit
Segment height	13 mm
Switching points and relay outputs	
Switching points	4 (for the control of one relay each)
Contact rating	115 V AC 1 A or 48 V DC 1 A (resistive load)
Temperature data	
Nominal temperature range	0...50 °C
Operating temperature range	-10...50 °C
Temperature deviation (10 °C)	
→ Measuring range zero point	< 0.005 %
→ Measuring range full scale value	< 0.003 %
Dimensions	
Overall	144 x 153 x 72 mm (L x W x H)
Dimensions for front panel cutout	138 x 68 (W x H)

FTA2USB

The FTA2USB digital measurement amplifier enables the simple connection of your force sensors or load cells to a PC. The matching WinFTA2USB software is included with the instrument. Together with a PC, this converts the measurement amplifier into a complete data logger that can export data to Microsoft Excel. Sensor adaptation and the measurement range scale, decimal point and resolution of the measurement amplifier are also programmed in the software.

Performance features

- Compact, small desktop device
- 2 strain gauge inputs 2 mV / V
- 4-wire connection
- Up to 4 or 8 sensors can be connected
- Accuracy < 0.01 %
- USB 2.0
- Power supply via USB
- WinFTA2USB software included

Options

Versions with channels for additional input signals, e. g. ± 10 V, 4...20 mA, or Pt100 temperature sensor input for the simultaneous acquisition of additional measurement signals. 24 V external power supply (required when using sensors with integrated measurement amplifier) 3 m USB cable



WinFTA2USB software

Easy to use software with a wide range of functions. You receive our WinFTA2USB software free of charge with the FTA2USB. All input channels can be monitored simultaneously. This allows the individual channels to be driven not only by force or weight transducers, but also by transducers for other physical quantities such as torque, distance, temperature, pressure or pulse rate. The convenient user interface makes it easy to configure the parameters for your specific measurement applications.

All parameters, including axis scaling, zero point, decimal points, sampling rate, peak hold, filter, etc., can be easily and quickly configured using the software. You can select either English or German as the user interface language. The measurement data can be exported to Microsoft Excel with a single click. The configuration can be saved in the FTA2USB, so that a configuration that has already been defined can be reloaded at any time as a template.

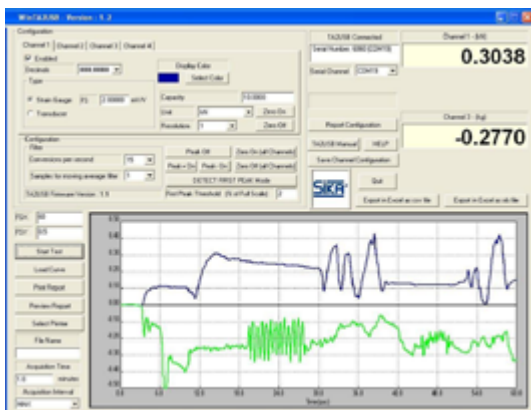

Technical data

FTA2USB digital measurement amplifier	
Accuracy	< 0.01 %
Linearity error	< 0.01 %
Resolution (2 mV / V)	±50 000 steps
Internal resolution	2 x ADC 24 bit
Sampling rate	5...4800 Hz
Strain gauge input	2 mV/V
Number of sensors that can be connected	4 (350 Ω) or 8 (700 Ω)
Bridge supply voltage	5 V DC ±4 %
Connection type	4-wire
Own weight	0.1 kg
Supply voltage	
Operating voltage	5 V DC (via USB)
Output signal	
USB 2.0	Max. 4800 samples/s
Temperature data	
Nominal temperature range	0...50 °C
Operating temperature range	0...70 °C
Temperature deviation (10 °C)	
→ Measuring range zero point	< 0.01 %
→ Measuring range full scale value	< 0.01 %
Dimensions	
Overall	100 x 86 x 36 mm (L x W x H)

Compact display units

FDFI and FDFX

Our FDFI and FDFX compact digital display units are handy, battery-operated instruments for the direct display of forces or weights. They can be configured for units of kN, daN, N, t and kg. The FDFI and FDFX differ in terms of accuracy, supply voltage and available options.

An integrated digital filter enables adaptation to individual conditions, for example for easy readout in applications subject to vibration. The standard batteries are integrated in the device, have a service life of one year, and can be replaced by the user. The device switches off automatically after an adjustable time in the absence of activity.

Performance features

- Compact device in handy size
- 5-digit digital display
- Battery operated
- Strain gauge input 2 mV/V
- 4-wire connection
- Supports 1 sensor connection
- Accuracy < 0.02%
- Peak-hold function

The FDFI and FDFX have an internal A/D converter with $\pm 32\,000$ steps; the standard 2 mV/V signal is resolved into $\pm 25\,000$ steps. The maximum sampling rate is 10 Hz. Various additional functions enable balancing out tare weights and measuring peak forces or weights.



Options

- Other strain gauge input signals: 1 mV/V or 3 mV/V
- RS 232C serial interface (FDFI)
- External operating voltage supply (FDFI)
- Version with increased sampling rate (200 Hz)
- Double connection for two sensors wired in parallel
- Carrying case with universal foam insert for mobile force measurement systems

Technical data

Compact display unit	FDFI	FDFX
Accuracy	< 0.02 %	< 0.04 %
Linearity error	< 0.015 %	< 0.015 %
Resolution (2 mV / V)	±25 000 steps	±25 000 steps
Internal resolution	±32 000 steps	±32 000 steps
Sampling rate	Max. 10 Hz (filter = 0)	Max. 10 Hz (filter = 0)
Strain gauge input	2 mV/V	2 mV/V
Number of sensors that can be connected	1 (350 Ω or 700 Ω)	1 (350 Ω or 700 Ω)
Supply voltage	5 V AC ±3%	3 V AC ±3%
Carrier frequency	100 Hz	100 Hz
Connection type	4-wire	4-wire
Degree of protection EN 60529	IP40	IP40
Own weight	0.5 kg	0.5 kg
Supply voltage		
Operating voltage	4 x 1.5 V, size AA	2 x 1.5 V, size AA
Battery replacement indicator	„LO BAT“	„LO BAT“
Automatic shutoff	1...30 min	1...60 min
Digital display		
LCD display	7 segments, 5-digit	7 segments, 5-digit
Segment height	16 mm	16 mm
Temperature data		
Nominal temperature range	0...50 °C	0...50 °C
Temperature deviation (10 °C)		
→ Measuring range zero point	< 0.015 %	< 0.015 %
→ Measuring range full scale value	< 0.015 %	< 0.015 %
Dimensions		
Overall	87 x 87 x 39 mm (L x W x H);	87 x 87 x 39 mm (L x W x H);

FPMA

Developed specifically for demanding applications, the professional FPMA compact display unit combines the advantages of a mobile measurement amplifier with the technical properties of a stationary device and a datalogger.

The special feature of this compact display unit is its high performance, which can otherwise only be achieved with fixed measurement amplifiers. Up to 4800 measurement values per second can be read with a resolution of $\pm 50\,000$ steps. This also makes the FPMA interesting for dynamic and highly-precise applications. Furthermore, the FPMA can be flexibly adapted to suit your application. This is particularly straightforward thanks to the automatic sensor detection of up to seven force sensors or load cells.

Along with the standard variant of the FPMA, a version with integrated force sensor or wireless measurement value transmission is also available.

To round off the wide functional scope, additional functions such as a datalogger with memory for 130,000 measurement values, filtering functions, detection of measurement value peaks and the preventative blocking of measurement values are available.

A USB connection is provided as standard on all units, which permits both real-time communication with the PC and charging the integrated Li-ion rechargeable battery.

Performance features

- Compact unit in an ergonomic, convenient format
- Large, illuminated and rotatable LCD display
- Battery-powered
- DMS input 2 mV / V
- 1 sensor connectible
- 4-wire connection type
- Accuracy < 0.010 %
- Datalogger integrated
- Automatic sensor detection
- USB interface



Options

- Integrated force sensor from 10 N to 5 kN
- Version available with wireless measurement signal transmission

Technical data

Compact display unit		FPMA
Accuracy		< 0.010 %
Resolution (2 mV / V)		±50 000 steps
Sampling rate		5...4800 Hz
Strain gauge input		2 mV/V
Number of sensors that can be connected		1 (350 Ω or 700 Ω)
Supply voltage		5 V DC ±4%
Connection type		4-wire
Degree of protection EN 60529		IP40
Supply voltage		
Operating voltage		Internal lithium ion battery
Automatic shutoff		1...99 min
Digital display		
LCD display		128 x 64 pixel, illuminated, rotatable
Temperature data		
Nominal temperature range		0...50 °C
Temperature deviation (10 °C)		
→ Measuring range zero point		< 0.010 %
→ Measuring range full scale value		< 0.010 %
Dimensions		
Overall		79 x 176 x 32 mm (L x W x H);

Overview measurement amplifier

Model	Amplifier		Output signal			Resolution (dark grey) and sampling (light grey)			
	Analogue	Digital	Analogue	Binary	MODBUS	± 1000 10 Hz	± 10 000 100 Hz	± 20 000 200 Hz	± 30 000 300 Hz
FTA4/2	✓		✓			Not applicable to analog amplifier systems			
FTA5F		✓		✓	✓				
FMP1		✓	✓						
FMP2E		✓	✓	✓	✓				
FTA2USB		✓		✓					
FDFI		✓		✓		FDFIF 200 Hz			
FDFX		✓							
FPMA		✓		✓					

		Connection				
$\pm 40\,000$ 400 Hz	$\pm 50\,000$ 500 Hz	Accuracy	Display	4-wire technology	6-wire technology	Number of mountable sensors
		< 0.02 %		✓		4 (350 Ω) or 8 (700 Ω)
	1000 Hz	< 0.01 %		✓	✓	4 (350 Ω) or 8 (700 Ω)
	$\pm 200\,000$	< 0.05 %	✓	✓		4 (350 Ω) or 8 (700 Ω)
		< 0.01 %	✓	✓	✓	6 (350 Ω) or 12 (700 Ω)
	4800 Hz	< 0.01 %		✓		4 (350 Ω) or 8 (700 Ω)
		< 0.02 %	✓	✓		1 (350 Ω or 700 Ω)
		< 0.04 %	✓	✓		1 (350 Ω or 700 Ω)
	4800 Hz	< 0.01 %	✓	✓	✓	1 (350 Ω or 700 Ω)

Mechanical and electronic accessories

Optimal coupling of the force or the weight to the sensor requires great care and can present a particular challenge in some applications. To optimise the integration of force sensors and load cells into your process, we provide special force coupling parts and assembly kits as accessories.

Suitable accessories ensure that every sensor can be seamlessly integrated into its corresponding application. We attach great importance to the quality and longevity of our accessory components. All parts are perfectly tailored to the respective sensor and enable faultless introduction of forces and loads to the sensor. The accessories are designed to protect the sensor from undesirable lateral forces, eccentric loads, vibrations and torques.

These accessories are described on the following pages:

- Knuckle eyes
- Compression fittings
- Base plates
- Weighing modules
- Weighing modules with vibration protection
- Wireless force sensors and load cells

The mechanical accessories guarantee optimum conditions for flawless measurement. Our knuckle eyes are ideally suited for the coupling of tensile forces and can be fitted quickly and precisely. The eyes, which move on bronze shell bearings, are specially designed to accept shackles.

Compression fittings and base plates provide suitable surfaces for coupling compression forces and loads. The flat surfaces of the base plates ensure that the sensors are held securely and perfectly upright. In this context, compression fittings act as the moveable counterpart to the base plate. They are flexible enough to adjust to the introduction of force or load. A base plate is generally always used in combination with a compression fitting – to provide a secure base for the sensor on the one hand while keeping the introduction of force or load flexible on the other.

For special requirements, we can supply special solutions: Our weighing modules offer enhanced mechanical performance features. Depending on the version, weighing modules can be designed with lift-off protection, anti-tilt protection, vibration protection and to allow easy sensor replacement.

The electronic components of force and weight measurement systems can also be checked, simulated and adapted with appropriate accessories. Terminal boxes allow multiple sensors to be wired in parallel. This makes it possible to summarise several sensor signals to form a net signal.

A special feature in the area of electronic accessories is our Wireless Modular System, which transmits measured values wirelessly and is available for many of our sensors.



Knuckle eyes, compression fittings and base plates

Knuckle eyes

Enable easy and quick assembly of sensors subjected to tension. The moveable eyes allow the sensor to be quickly mounted and removed from the equipment.



Knuckle eyes are provided for the following sensors: FTC4, FTSTM, FTCETM, FTCA, FTCE, FTS

Knuckle eyes



Compression fittings

If the sensor is subjected to compression, you can create an excellent bearing surface by using compression fittings to provide a coupling surface for the force.

The compression fitting consists of a cylindrical body and a bearing-mounted head that fits on the body. In addition to providing a large, flat surface, the compression fittings are able to compensate for eccentric loads.



Compression fittings are provided for the following sensors: FTC4, FC8S, FTSTM, FTCETM, FTCA, FTCE, FTS, FC2S, FCBS

Compression fittings



Base plates

Base plates ensure a secure position and provide a flat bearing surface for the sensor. The use of base plates is generally recommended. Especially if proper installation of the sensor is otherwise not assured.



Base plates are provided for the following sensors: FTC4, FTSTM, FTCA, FTS

Base plates



Weighing modules

Specifically adapted to our load cells, SIKa weighing modules form the best design basis for optimal measurement. The base plate with sensor mount provides an even and secure seating for the load cell. Clean load coupling is enabled by a compression fitting and the bearing-mounted top part of the module.

Integrated lift-off protection offers security. It prevents the top part of the weighing module from coming loose from the bottom part in the case of a tipping load. A special advantage is easy sensor replacement. If it needs to be replaced, the entire weighing module can be raised and locked using adjusting screws, even under load. In this way, the sensor can easily be removed and replaced.

These modules were specially developed to simplify the assembly of weighing and dispensing systems and for tanks, containers, silos, and stationary or vibrating funnels. Our weighing modules feature load self-alignment, lateral displacement compensation and height adjustment.



Weighing module



Weighing modules are provided for the following sensors: FC2S, FCBS

Weighing modules with vibration protection

These weighing modules come to the fore under difficult conditions with vibration. Elastomer mounting suppresses unwanted vibrations, for example in conveyor belt weighers or mixing vessels.



Vibration protection



Weighing modules are provided for the following sensors: FFT1

Force and weight measuring systems without cables

Wireless Modular

Does your application impose special requirements on the installation situation and the flexibility of force sensors, with cable installation being especially difficult? Our solution is Wireless Modular.

Many of our force sensors and load cells can be equipped with this special module for wireless measurement data transmission.

The strengths of the system are best seen in application which do not permit any connecting cables to the sensor, which have a large distance between the sensor and the display, or in which the sensor location must be constantly changed.

Performance features

- Up to 32 sensors can be combined in a network
- Range up to 200 m between sensor and receiver possible
- Battery life up to 1,000 hours per charge.
- WinWiMOD software available as an accessory.
- Many SIKA force sensors and load cells are available with Wireless Modular.

A system consists of a force sensor or a load cell fitted with a Wireless Modular module. The receiver consists of antenna and a connecting cable with either a USB or a RS-232 connector.



A battery charger that can be connected directly to the sensor is provided to recharge the battery of the Wireless Modular module after around 1000 operating hours.

For optimal connection of the sensors to your PC, we recommend the use of our WinWiMOD software.

You can also process the measurement data according to your particular wishes, for example with a PLC, or you can read the values directly on the SIKA FMP2E on site.

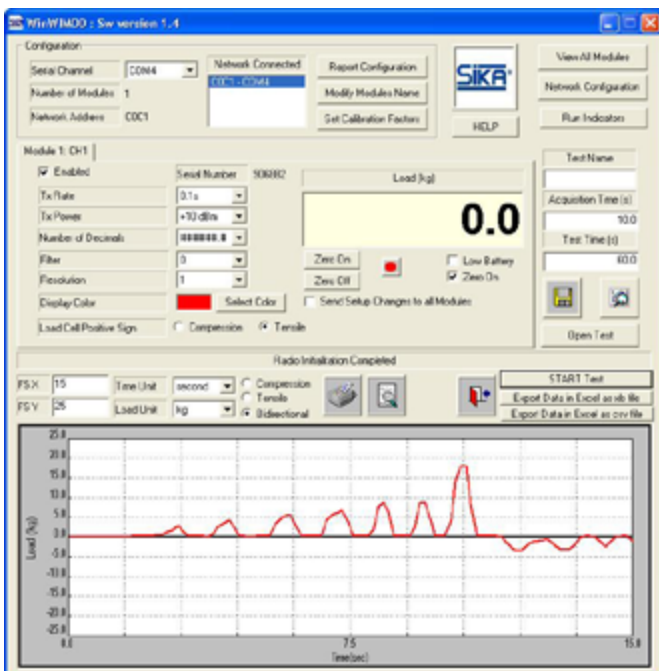

We can equip the following sensors with the Wireless Modular System for you:
FC2S, FC8S, FTC4, FD200, FTCE, FTCETM

Wireless Modular force and weight measuring system	
Accuracy	< 0.05 %
Rated characteristic value	2 mV / V
Resolution (2 mV / V)	±10 000 steps
Range	Max. 200 m linear distance without obstacles
Selectable measurement units	cN, N, daN, kN, MN, kg, lb, klb, t
Degree of protection EN 60529	IP65 (sensor with Wireless Modular module) IP40 (receiver unit)
Wireless Modular housing	Aluminium
Own weight	0.9 kg
Supply voltage	
Operating voltage	Rechargeable Li-ion battery (3.6 V) Up to 1000 operating hours per charge
Temperature data	
Nominal temperature range	0...50 °C
Operating temperature range	-10...50 °C
Dimension	
Overall	85 x 38 x 60 mm (L x W x H)

FSG4 terminal boxes and software

In weighing technology applications, e. g. for platform scales, several load cells are wired together. The FSG4 terminal box is ideally suited for this. The load cells are wired in parallel in the terminal box, and the net signal is conducted by a cable to the measurement amplifier.

Performance features

- Sturdy aluminium housing (IP65)
- 5 cable glands for 6-mm sensor cables
- Supports 4-wire or 6-wire connection of load cells
- Inputs for four sensors; one output

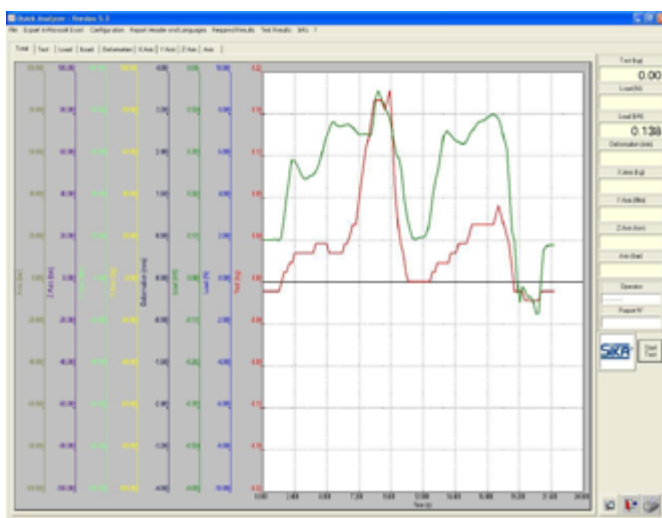
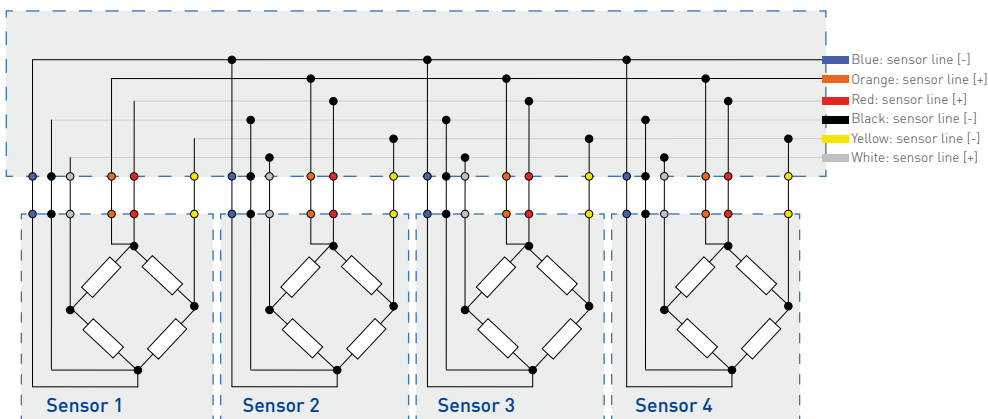

Software QuickAnalyzer

Many of our measurement amplifiers provide the option of collecting and recording measurement data in real time on a PC. QuickAnalyzer offers the broadest functional scope of all the SIKA software solutions and is compatible with a large number of our measurement amplifiers.

The software allows for quick and easy configuration of sensors and measurement amplifiers from a PC. Eight input channels can be monitored and recorded simultaneously. In addition to measuring force and weight, they can be used to record other input quantities such as torque, distance, pressure etc. A zoom function to allow detailed examination of the measurement curve and a function for exporting data are just two of the many features of QuickAnalyzer.



QuickAnalyzer is available for the following measurement amplifiers:
 FMP10, FDFI / FDFIF, FMP2E, FTA2USB, FTA5F, Wireless Modular

Combination units

Our combination units incorporate a sensor, measurement amplifier and display in a single unit. This results in flexible force and weight measurement devices which can be operated without an external voltage supply.

The optional transport case is the perfect travel solution for the combination unit and accessories, making them particularly suitable for mobile measurement tasks. Compression fittings are available as accessories for compression loads. Knuckle eyes are particularly suitable for tensile loads and can be supplied with shackles, which allow the combination units to be integrated, for example, as a tensile or hanging scale.

These combination units are described on the following pages:

- Combination unit FDNA for tensile and compression loads
- Combination unit FGR5A for tensile load
- Combination unit FDFIW



Combination units for compression forces

FDFIW

Our FDFIW is a portable force-measuring unit consisting of a force sensor, measurement amplifier, and local display. This unit is suitable for fast and convenient measurement of large spot pressure forces such as clamping forces on welding tongs, presses and similar.

This device is battery-powered; conventional batteries as available on the market are integrated into the unit, and have a lifetime of around a year. You can also change them yourself. The unit switches off automatically if not used after an adjustable period.

Performance features

- Compact unit in a convenient format
- Five-digit digital display
- Measurement ranges available from 10–40 kN
- Peak-hold function
- Battery-powered

Options

- RS 232C serial output
- Version with increased sampling rate (200 Hz)

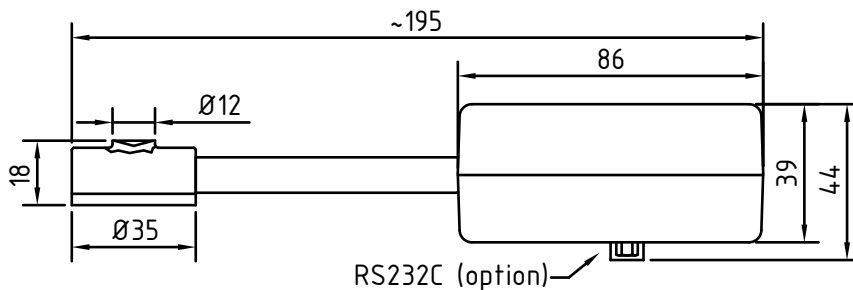

Technical data

Combination unit for compression forces FDFIW	
Nominal load	10 / 20 / 30 / 40 kN
Load transfer direction	Compression
Accuracy	< 0.500 %
Material	Stainless steel, housing aluminium
Degree of protection EN 60 529	IP40
Linearity	< 0.200 %
Hysteresis	< 0.200 %
Repeatability	< 0.050 %
Temperature influence zero signal for each 10 °C	< 0.100 %
Temperature effect on characteristic value per 10 °C	< 0.025 %
Own weight	~ 0,6 kg
Maximalbelastung	
Operating load	120 % of E_{max}
Load limit	150 % of E_{max}
Breaking load	> 300 % of E_{max}
Lateral load limit	50 % of E_{max}
Temperature data	
Reference temperature	23 °C
Nominal temperature range	0...40 °C
Operating temperature range	0...70 °C
Supply voltage	
Operating voltage	4 x 1.5 V, size AA
Battery replacement indicator	„LO BAT“
Automatic shutoff	1...30 min
Digital display	
LCD Display	7 segments, 5-digit
Segment height	16 mm
Dimensions	
Overall	192 x 82 x 44 mm

Combination units for tensile and compression forces

FDNA

A sensor, measurement amplifier and display in a single unit. This intelligent combination results in a compact force measuring unit whose display and battery-powered operation makes it extremely versatile and easy to use without a power supply.

High-quality components give the FDNA an impressive technical performance. It offers a large bearing sure face for coupling forces in the compression direction. An integrated thread allows for the optimum coupling of tensile forces.

The flexibility is not only confined to the diverse fields of application of the FDNA. The configuration options also offer plenty of scope to configure the device to your specific application.

As well as wide range of measurement units such as kg, t, N, daN or kN, additional functions such as peak, zero and other possible settings are available.

Ease of use, multifunctional capabilities, mobility and a compact design - these are the strengths of the FDNA combination unit.

Performance features

- Accuracy < 0.05 %
- Peak-hold function
- Compact design and low weight
- Battery life approx. 1 year without re-charging
- Versatile applications
- Quick installation and removal



Options

- Serial interface RS 232C
- Transport case
- Knuckle eyes and shackles for tension load available

Technical data

Combination unit for tensile and compression forces FDNA

Nominal load	100 kg	200 kg	500 kg	1 t	2.5 t	5 t
Load transfer direction						
→ Tension	✓	✓	✓	✓	✓	
→ Compression	✓	✓	✓	✓	✓	✓
Accuracy	< 0.050 % of E _{max}					
Sampling rate	10 Hz					
Resolution	0.01 kg	0.01 kg	0.05 kg	0.1 kg	0.2 kg	0.5 kg
Degree of protection EN 60 529	IP40					
Own weight	~ 1.5 kg					
Load limit						
Service load	120 %					
Safe load limit	150 %					
Breaking load	> 300 %					
Max. permissible dynamic load	50 %					
Temperature data						
Reference temperature	23 °C					
Nominal temperature range	0...40 °C					
Service temperature	0...50 °C					
Supply voltage						
Operating voltage	4 x 1.5 V, Size AA					
Battery replacement indicator	„LO BAT“					
Automatic shutoff	1...30 min					
Digital display						
LCD Display	7 segments, 5-digit					
Segment height	16 mm					
Dimensions						
Overall	108 x 93 x 59 mm					

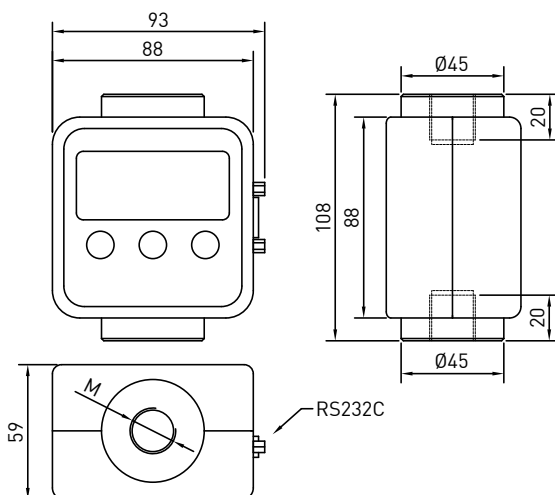

Load	M
100 kg	M12
200 kg	M12
500 kg	M12
1 t	M20 x 1.5
2.5 t	M20 x 1.5
5 t	M20 x 1.5

Hanging scales

FGR5A

The FGR5A is designed to take tensile load measurements in situations that call for direct indication of measured values and straightforward connection to the measuring device.

The unit consists of a load cell, which offers particularly good long-term stability, combined with a compact display device. This display device consists of a digital measurement amplifier with an integrated digital display and bar graph. The metal housing provides the requisite sturdiness and protects the device from outside influences.

The shackle allows the FGR5A to be quickly integrated into and removed from the application. The four replaceable standard batteries provide an operating time of around one year.

Energy management in the device is optimised by an automatic shut-off function, which is triggered when the unit is not in use. Excessive loads are clearly indicated by an acoustic warning signal.

Performance features

- Supplied with remote control
- High accuracy and long-term stability
- Robust and compact design
- Quick and easy installation and removal
- Zero and peak-hold function

Options

- Serial interface RS 232C



Technical data

Hanging scales FGR5A					
Nominal load	500 kg	1 t	3 t	6.5 t	9.5 t
Load transfer direction	Tension				
Accuracy	< 0.050 % E _{Max}				
Sampling rate	1 Hz				
Resolution	0.1 kg	0.2 kg	0.5 kg	1 kg	2 kg
Save load limit	150 % full scale				
Security coefficient	> 5				
Degree of protection EN 60529	IP20				
Own weight	3.5 kg		7.5 kg		12 kg
Supply voltage					
Operating voltage	4 x 1.5 V, Size AA				
Digital display					
LCD Display	7 segments, 5-digit				
Segment height	25 mm				
Dimensions					
Overall	270-477 x 161 x 123 mm				

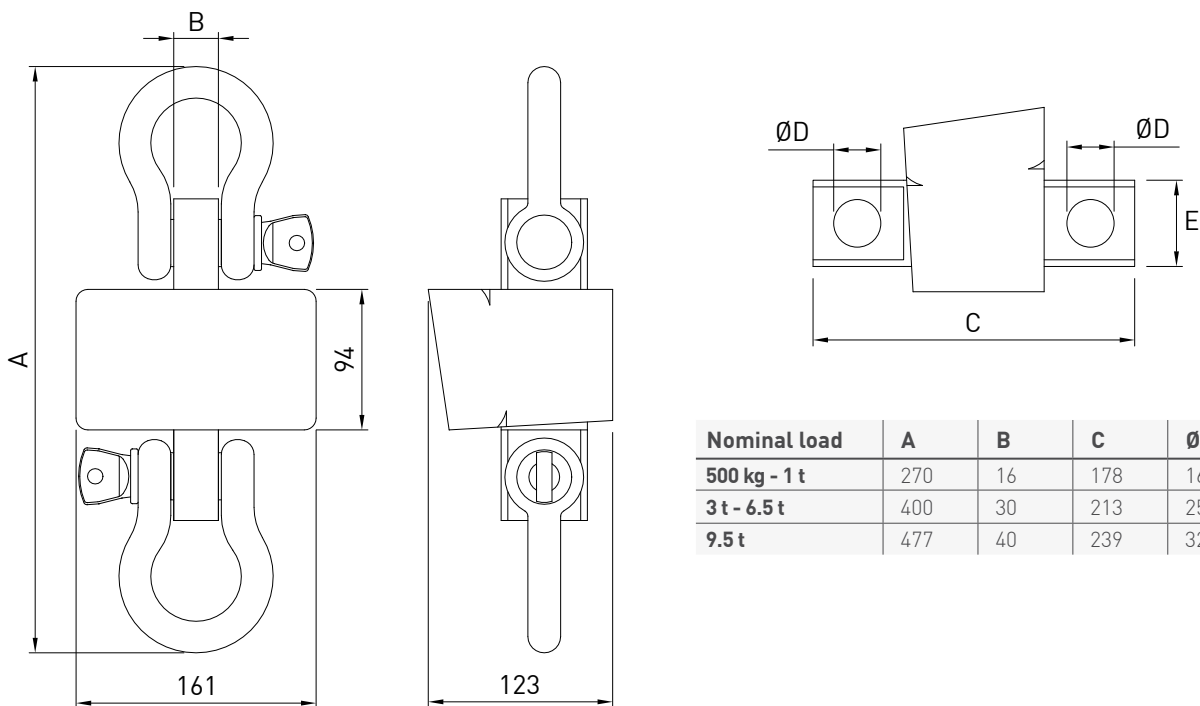

Nominal load	A	B	C	ØD	E
500 kg - 1 t	270	16	178	16	57
3 t - 6.5 t	400	30	213	25	57
9.5 t	477	40	239	32	70

Force calibration systems

Many applications which involve the measurement of forces are calibrated as a complete system and must be recalibrated in due course. Particularly in the case of applications such as testing machines, calibration of the machine as a whole is extremely important.

For the calibration and recalibration of these types of systems, we developed our force calibration systems. They consist of a high-precision measurement amplifier combined with one of our force sensors specially developed for calibration purposes.

The use of the suitable sensor FMKAL or FKAL is determined by the required force range. The two sensors provide for calibrations of less than one Newton all the way to 1 MN. Both sensors are capable of calibrating for tensile as well as compression loads across the entire measurement range.

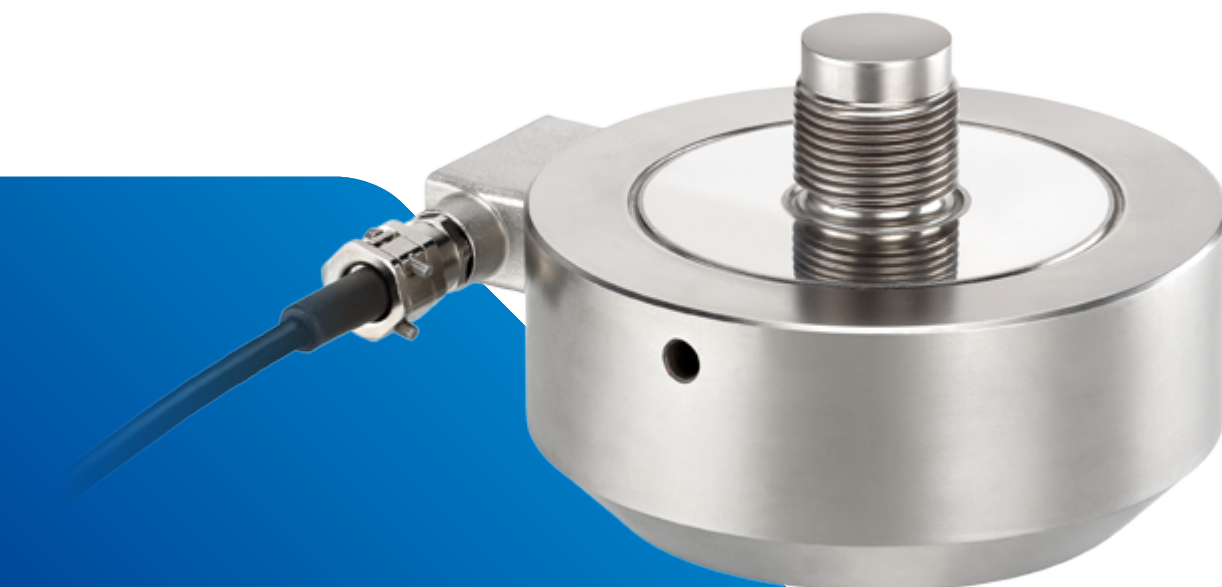

In addition to the highly accurate sensors, the measurement chain of the force calibration systems consists of our FMP10 laboratory measurement amplifier. This amplifier is specially developed for use in calibration laboratories and in force calibration systems. In order to meet the highest requirements of a force calibration system, the FMP10 is extremely accurate, with high resolution and a linearization function.

Our software ForceKAL offers a wide range of functions and allows easy creation of calibration protocols.

SIKA force calibration systems are used in a variety of applications that ranges from calibrating force sensors in calibration laboratories to calibrating entire systems – particularly in material and universal testing machines – all the way to recalibrating these types of machines.

Tailored precisely to the application cases, these force calibration systems offer the following advantages:

- Simple mechanical integration of the sensor into the testing machine
- Highly accurate calibration capabilities thanks to precise sensor and measurement amplifier
- Direct creation of calibration certificates using the ForceKAL software



Force calibration sensors

FMKAL and FKAL

Our FMKAL and FKAL calibration sensors are tailored to the requirements of force calibration systems. Thanks to excellent technical characteristics with regard to accuracy and mechanical structure, these sensors deliver optimum performance.

The monolithic structure, optimised by the finite elements method, results in a compact design, low own weight and straightforward integration of the sensor into the process. Consequently, the sensors can easily serve as force references in confined spaces.

Eccentric forces can be almost entirely offset.

Performance features

- Excellent technical measurement characteristics
- Compensation of eccentric forces $< 0.005\%$ of F_{nom}
- Easy to handle thanks to compact design and low own weight
- Allows calibration of tensile and compression loads
- Wide range of mechanical mounting aids available



FMKAL

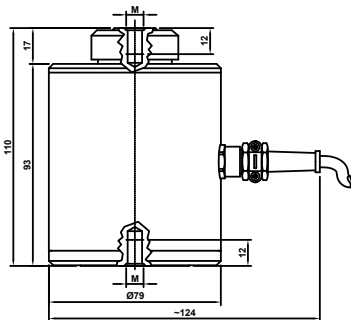

FKAL

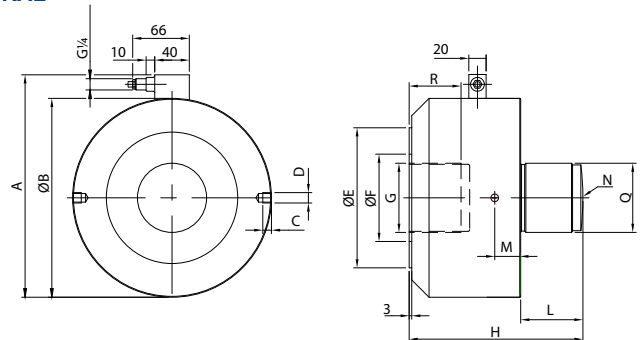

FKAL

Force	A	ØB	C	D	ØE	ØF	G	H	L	M	N	Q	R
10 kN	152	127	12	M8	84	61	M42 x 3	91	33	10	R65	M30 x 2	20
25 kN													
50 kN													
100 kN	190	165	20	M10	112	71	M56 x 3	114	42	12	R160	M42 x 3	31
200 kN								135					
300 kN													
500 kN	225	230	24	M12	162	101	M80 x 2	179	72	15	R300	M80 x 2	46
750 kN								201					
1000 kN								204					

Technical data

Force calibration sensors		FMKAL			FKAL		
Rated force	(F _{nom})	50 / 100 / 200 / 500 N					
		1 / 2 / 3 / 5 kN			10 / 25 / 50 / 100 / 200 / 300 / 500 / 750 / 1000 kN		
Force transfer direction		Compression and tension					
ISO 376 accuracy class		00	0,5	1	00	0,5	1
Nominal Sensitivity	(C _{nom})	2 mV/V					
Material		Stainless steel					
Degree of protection EN 60529		IP40			IP67		
Encapsulation		Hermetically sealed by welding					
Own weight		1.7 kg			13 - 36 kg		
Cable length		5 m					
Nominal displacement	(s _{nom})	0.2 mm					
Error limits							
Linearity		0.020 % of F _{nom}	0.020 % of F _{nom}	0.020 % of F _{nom}	0.020 % of F _{nom}	0.020 % of F _{nom}	0.020 % of F _{nom}
Hysteresis		0.020 % of F _{nom}	0.020 % of F _{nom}	0.020 % of F _{nom}	0.020 % of F _{nom}	0.020 % of F _{nom}	0.020 % of F _{nom}
Relative zero offset		0.005 % of F _{nom}	0.010 % of F _{nom}	0.010 % of F _{nom}	0.005 % of F _{nom}	0.010 % of F _{nom}	0.010 % of F _{nom}
Temperature effect on zero signal per 10 °C		0.015 % of F _{nom}	0.015 % of F _{nom}	0.015 % of F _{nom}	0.015 % of F _{nom}	0.015 % of F _{nom}	0.015 % of F _{nom}
Temperature effect on characteristic value per 10 °C		0.010 % of F _{nom}	0.010 % of F _{nom}	0.010 % of F _{nom}	0.010 % of F _{nom}	0.010 % of F _{nom}	0.010 % of F _{nom}
Relative repeatability 0° / 120° / 240°		0.020 %	0.045 %	0.080 %	0.020 %	0.045 %	0.080 %
Relative interpolation error		0.020 %	0.040 %	0.050 %	0.020 %	0.040 %	0.050 %
Relative reversibility		0.030 %	0.050 %	0.090 %	0.030 %	0.050 %	0.090 %
Electrical data							
Input resistance	(R _e)	350 ± 2 Ω			700 ± 2 Ω (10...50 kN) / 350 ± 2 Ω (100...1000 kN)		
Output resistance	(R _a)	352 ± 2 Ω			705 ± 2 Ω / 352 ± 2 Ω		
Insulation resistance	(R _{is})	> 5 GΩ					
Zero signal tolerance	(d ₀)	< 0.500 % of F _{nom}			< 0.200 % of F _{nom}		
Supply voltage	(B _{nom})	1...15 V (typical 10 V)					
Operating voltage	(B _g)	18 V					
Maximum load							
Operating force	(F _G)	120 % of F _{nom}					
Force limit	(F _{lim})	150 % of F _{nom}					
Breaking force	(F _B)	> 300 % of F _{nom}					
Lateral force limit	(F _Q)	100 % of F _{nom}					
Maximum dynamic load		75 % of F _{nom}					
Temperature data							
Reference temperature		23 °C					
Nominal temperature range		-10...40 °C					
Operating temperature range		-20...70 °C					

Digital measurement amplifier

FMP10

Best technology for highest performance: The amplifier FMP10 was developed specifically for use in the laboratory and in force calibration systems. For these applications the FMP10 provides memories for up to ten calibration-sensors. With this function, all configuration of the sensors can be saved and recalled at any time, which saves much time during the calibration of different force ranges.

In addition to a very high resolution, the FMP10 is characterized by an internal self-checking reference, a wide range of other functions and a linearization function.

The linearization function allows to compensate the interpolation error of the calibration sensors.

Performance features

- A / D converter with $\pm 500\,000$ steps
- Linearization function for sensor signal
- Serial interface for connection to a PC
- ForceKAL software allows easy creation of calibration certificates

The FMP10 features an illuminate graphic display and five function keys, which allow full configuration of the measurement amplifier. Our digital measurement amplifier is equipped with an internal A/D converter with $\pm 500\,000$ steps; the standard 2 mV/V signal is triggered in $\pm 200\,000$ steps. The sampling rate is 50 measurement values per second.

Type FMP10

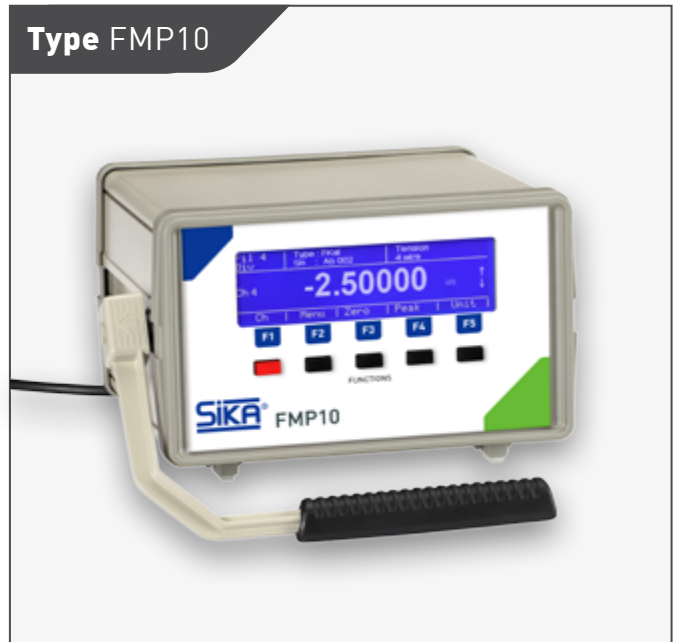

Options

- Other DMS input signals: 1 mV / V or 3 mV / V
- Basic version with memory for two sensors, without linearization function available

Technical data

Digital measurement amplifier	FMP10	FMP10 / 2
Accuracy	< 0.0025 %	
Linearity error	< 0.0015 %	
Linearization function	Yes	No
Resolution (2mV / V)	±200 000 divisions	
Internal resolution	±500 000 divisions	
Sampling rate	Max. 50 Hz (Filter = 0)	
Strain gauge input	2 mV/V	
Number of sensors that can be connected	1 (350 Ω or 700 Ω)	
Programmable Channels	10	2
Supply voltage	5 V AC ±3 %	
Connection type	4- or 6-wire technology	
Own weight	2.5 kg	
Supply voltage		
Operating voltage	230 V AC ±10 %, 50...60 Hz	
Power consumption	10 VA	
Digital display		
LCD Display	240 x 64 pixel	
Temperature data		
Reference temperature	0...50 °C	
Service temperature	0...50 °C	
Temperature effect (10 °C)		
→ Measuring range zero point	< 0.005 %	
→ Measuring range full scale value	< 0.005 %	
Dimensions		
Overall	210 x 204 x 125 mm (L x W x H)	