

Technical brochure

Stop Needle Valves SNV-ST and SNV-SS



SNV-ST and SNV-SS valves are designed to meet all industrial refrigeration application requirements. Designed as service valves they provide favourable flow characteristics.

Features

- Applicable to HCFC, non flammable HFC, R717 (Ammonia) and R744 (CO₂).
- Suitable for "heavy duty" industrial applications having a very sturdy and safe design including high pressures and wide temperature range.
- The SNV-ST and SNV-SS valves have backseating (metal to metal).
- Compact and light valve for easy handling and installation
- No special flow direction required.
- Provide high flow characteristics.
- Each valve type is clearly marked with type and size.
- Housing and bonnet material is low temperature steel (stainless steel for SNV-SS) according to requirements of the Pressure Equipment Directive and other international classification authorities.
- Valve safety is enhanced with the spindle being secured such that it cannot be unscrewed.
- Max. operating pressure: 52 bar g (754 psig)
Valves for higher operating pressure available on request
- Full temperature range: -60/+150°C (-76/+302°F)

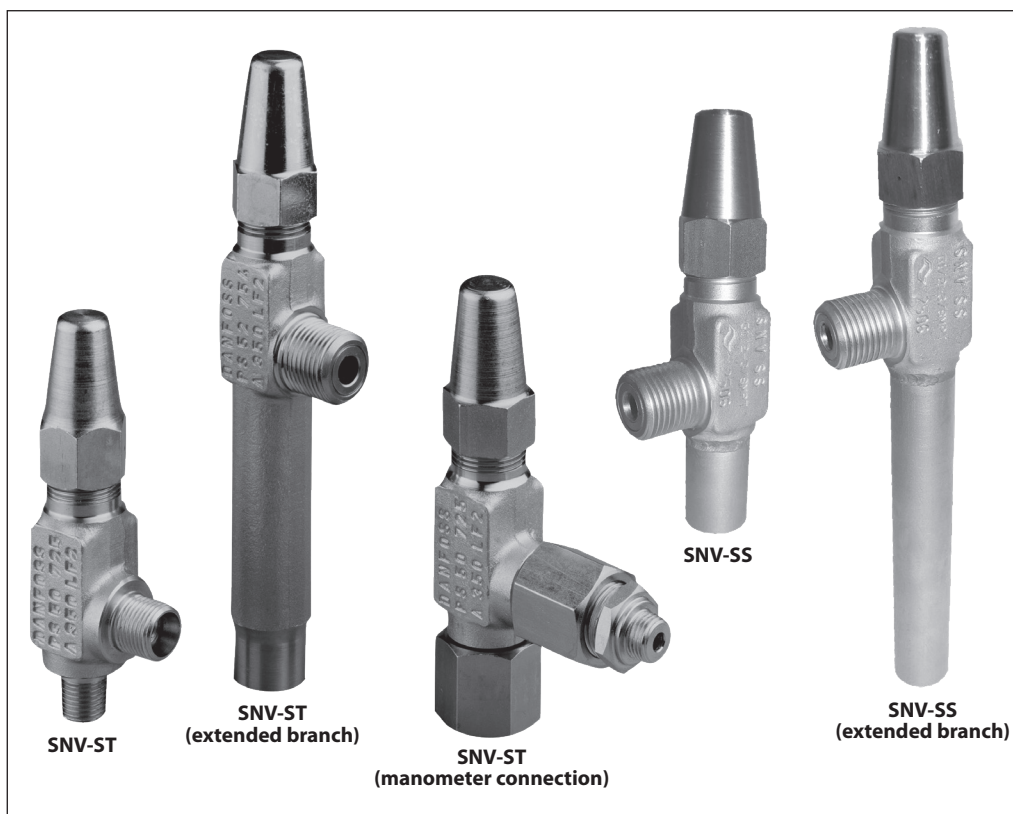

Technical data

- **Refrigerants**
Applicable to HCFC, non flammable HFC, R717 (Ammonia) and R744 (CO₂). For further information please see installation instruction for SNV-ST.
 - **Temperature range**
-60/+150°C (-76/+302°F).
 - **Maximum working pressure**
The valve is designed for: Maximum operating pressure of 52 bar g (754 psig). Valves for higher operating pressure available on request.
- For further information please contact your local Danfoss Sales Company.

Design

Connections
Available with the following connections:

- CD Cutting ring
- MPT Male NPT ANSI
- FPT Female NPT ANSI
- G
- W Welding connection

Housing
Made of special steel, approved for low temperature operations.

Spindle
Equipped with stainless steel spindle, which is ideal for O-ring sealing.

Installation

No special flow direction is required. The valve is designed to withstand high internal pressures. However, the piping system in general should be designed to avoid liquid traps and reduce the risk of hydraulic pressure caused by thermal expansion. For further information refer to installation instruction for SNV-ST and SNV-SS.

Stop Needle Valve, type SNV-ST and SNV-SS

Connections

CD 6
CD 10

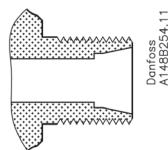

Danfoss
A1148B258.11

Cutting ring, DIN 3861 & DIN 3901 class L,
 $d_u = 6 \text{ mm}$

Cutiing ring, DIN 3861 & DIN 3901 class L,
 $d_u = 10 \text{ mm}$

1/4 MPT
3/8 MPT

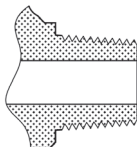

1/4" male NPT ANSI
3/8" male NPT ANSI

1/4 FPT
3/8 FPT

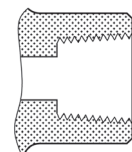

1/4" female NPT ANSI
3/8" female NPT ANSI

G 1/2"

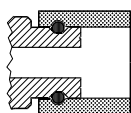
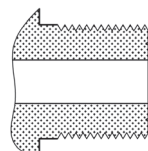

G 1/2"

W

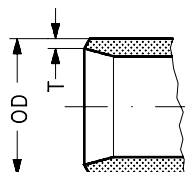

1/2" welding connection
OD = 21.3 mm (0.839 in.)
T = 2.3 mm (0.091 in.)

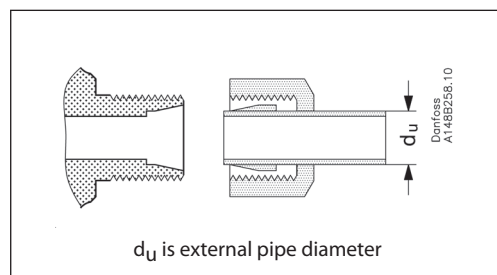

d_u is external pipe diameter

Note: Fittings not included

Stop Needle Valve, type SNV-ST and SNV-SS

Material specification

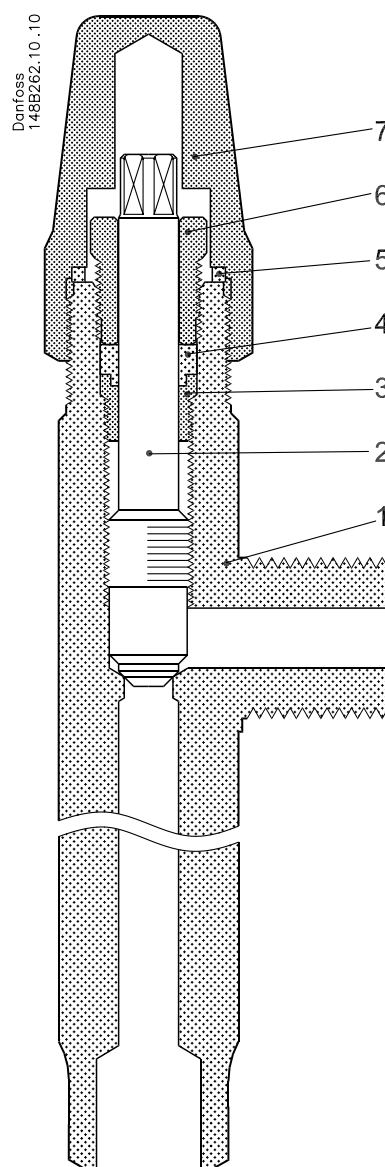
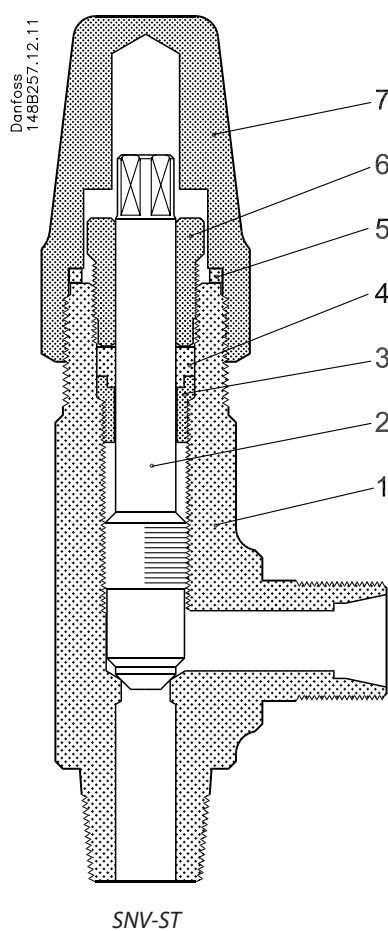

No.	Part	Material	EN	JIS	ASTM
1	Housing	Steel	P285QH EN 10222-4	SFL 2 G 3205	LF2 A350
		Stainless steel (SNV-SS)	X5CrNi18-10, 10088		AISI 304
2	Spindle	Stainless steel	X8CrNiS 18-9 EN 10088' DIN 17440 (SNV-SS only)	SUS 303	AISI 303
3	Locking ring	Steel			
4	Sealing ring	Teflon			
5	Seal cap gasket	Nylon			
6	Gland nut	Steel			
7	Seal cap	Steel			

Stop Needle Valve, type SNV-ST and SNV-SS

Dimensions and weights

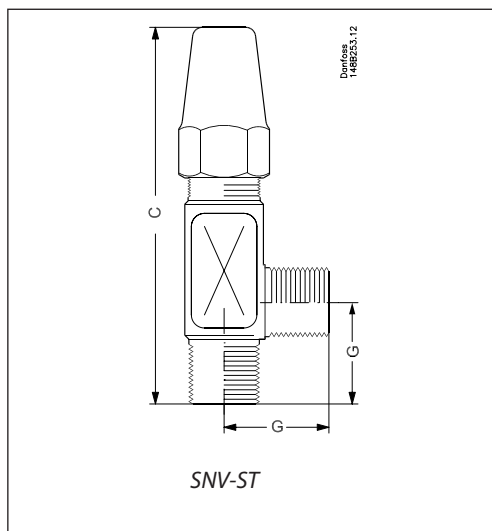

Type		C	G	Weight
SNV-ST	mm	115	32	0.36 kg
	in.	4.53	1.26	0.79 lb

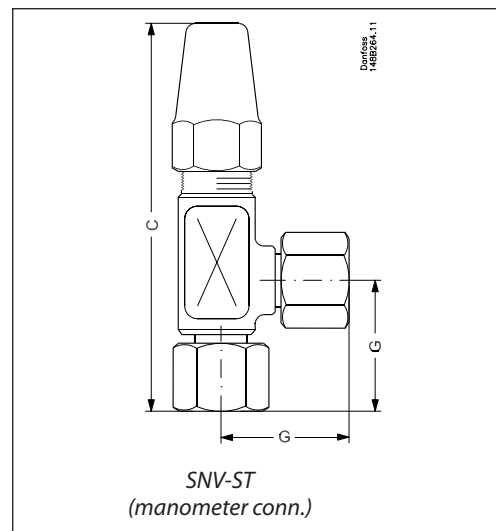

Type		C	G	Weight
SNV-ST (Man.)	mm	127	45	0.56 kg
	in.	5.00	1.77	1.22 lb

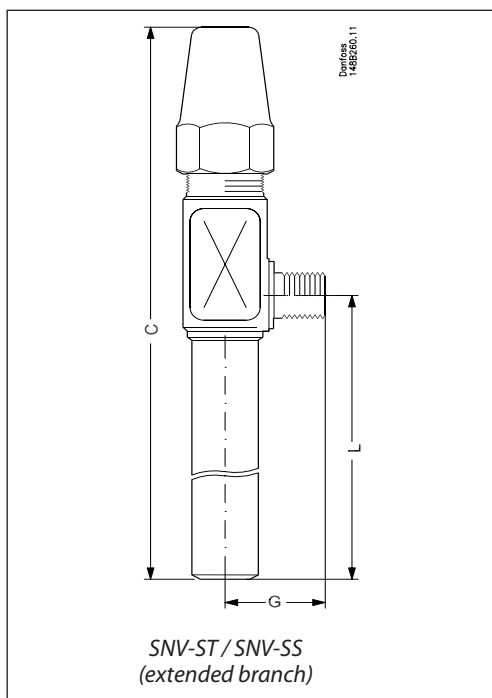

Type		C	G	L	Weight
SNV-ST, SNV-SS Ext.branch	mm	131	32	50	0.60 kg
	in.	5.16	1.26	1.97	1.32 lb
SNV-ST Ext.branch	mm	181	32	100	0.60 kg
	in.	7.13	1.26	3.94	1.32 lb
SNV-SS Ext.branch	mm	206	32	125	0.60 kg
	in.	8.11	1.26	4.92	1.32 lb
SNV-SS Ext.branch	mm	231	32	150	0.60 kg
	in.	9.09	1.26	5.91	1.32 lb

Specified weights are approximate values only.

Stop Needle Valve, type SNV-ST and SNV-SS

Ordering

How to order

The table below is used to identify the valve required.

Please note that the type codes only serve to identify the valves, some of which may not form part of the standard product range. For further information please contact your local Danfoss Sales Company.

Important!

Where products need to be certified according to specific certification societies or where higher pressures are required, the relevant information should be included at the time of order.

See figure 1

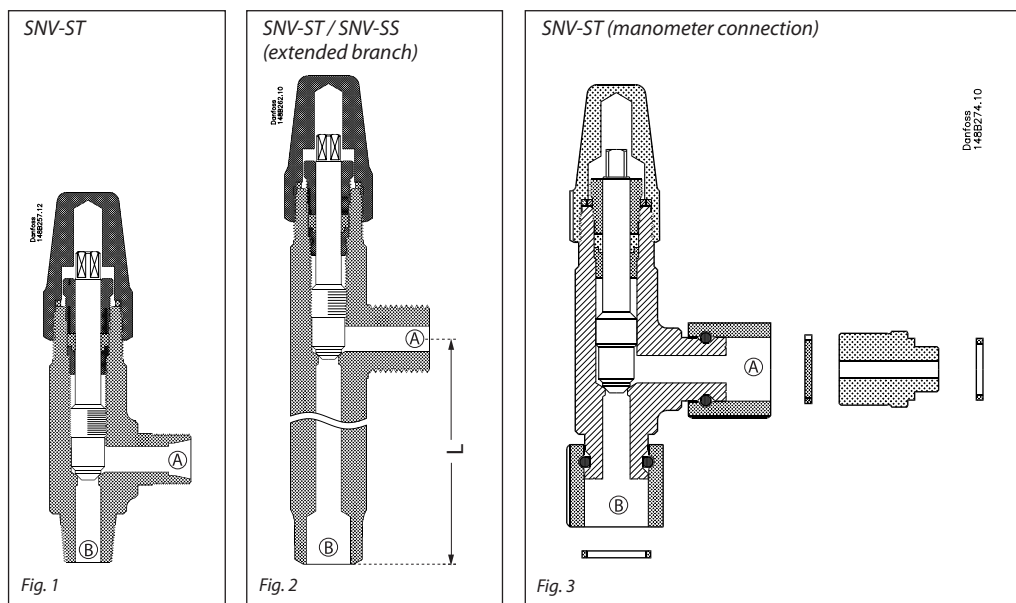

Side branch connection (A)	Bottom branch connection (B)	Type	Quantity	Code No.
CD 10	CD 10	SNV-ST CD10-CD10	1 pc.	148B3740
CD 10	CD 10	SNV-ST CD10-CD10	30 pcs.	148B4177
CD 10	¼ MPT	SNV-ST CD10-1/4MPT	1 pc.	148B3741
CD 6	¼ MPT	SNV-ST CD6-1/4MPT	1 pc.	148B3742
CD 10	⅜ MPT	SNV-ST CD10-3/8MPT	1 pc.	148B3743
CD 6	⅜ MPT	SNV-ST CD6-3/8MPT	1 pc.	148B3744
G ½ (external)	G ½ (external)	SNV-ST G1/2-G1/2	1 pc.	148B3745
G ½ (external)	G ½ (external)	SNV-ST G1/2-G1/2	30 pcs.	148B4179
¼ FPT	¼ MPT	SNV-ST 1/4FPT-1/4MPT	1 pc.	148B3746
¼ FPT	¼ MPT	SNV-ST 1/4FPT-1/4MPT	30 pcs.	148B4180
⅜ FPT	⅜ MPT	SNV-ST 3/8FPT-3/8MPT	1 pc.	148B3747
⅜ FPT	⅜ MPT	SNV-ST 3/8FPT-3/8MPT	30 pcs.	148B4181
⅜ FPT	½ MPT	SNV-ST 3/8FPT-1/2MPT	30 pcs.	148B4233
¼ FPT	¼ FPT	SNV-ST 1/4FPT-1/4FPT	30 pcs.	148B4223
½ MPT	½ MPT	SNV-ST 1/2MPT-1/2MPT	30 pcs.	148B4224
⅜ FPT	⅜ FPT	SNV-ST 3/8FPT-3/8FPT	30 pcs.	148B4225
½ MPT	⅜ FPT	SNV-ST 1/2MPT-3/8FPT	30 pcs.	148B4226
CD 6	¼ MPT	SNV-ST CD6-1/4MPT*	30 pcs.	148B4216
7/16 UNF	¼ MPT	SNV-ST 7/16UNF-1/4MPT	30 pcs.	148B4230

* With handwheel

Extended Branch

Side branch connection (A)	Bottom branch connection (B)	Type	Quantity	Code No.
CD10	W½ L100	SNV-ST CD10-W1/2 L100	1 pc.	148B3768
CD10	W½ L100	SNV-ST CD10-W1/2 L100	30 pcs.	148B4210
G ½ (external)	W½ L100	SNV-ST G1/2-W1/2 L100	1 pc.	148B3769
G ½ (external)	W½ L100	SNV-ST G1/2-W1/2 L100	30 pcs.	148B4211
G ½ (external)	W½ L125	SNV-ST G1/2-W1/2 L125	30 pcs.	148B4219
G ½ (external)	W½ L50	SNV-ST G1/2-W1/2 L50	30 pcs.	148B4218
G ¼ (internal)	R¼ L50 (external)	SNV-ST G1/4-R1/4 L50	30 pcs.	148B4231
¼ FPT	¼ MPT L100	SNV-ST 1/4FPT-1/4MPT L100	30 pcs.	148B4232
G ½ (external)	W½ L50	SNV-SS G1/2-W1/2 L50	1 pc.	148B4265
G ½ (external)	W½ L150	SNV-SS G1/2-W1/2 L150	1 pc.	148B4266
G ⅝ (external)	W½ L125	SNV-ST G3/8-W1/2 L125	30 pcs.	148B4336

See figure 2

L50 = 50 mm (2 in.)

L100 = 100 mm (4 in.)

L125 = 125 mm (5 in.)

L150 = 150 mm (6 in.)

See figure 3



Manometer connection

Side branch connection	Bottom branch connection	Type	Quantity	Code No.
G ½	G ½	SNV-ST G½ Man	1 pc.	148B3778**

** Including adaptor for connection to ICS/PM valve.

Stop Needle Valve, type SNV-ST and SNV-SS

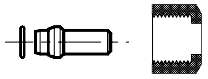
Accessories

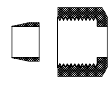
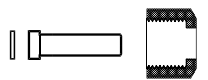
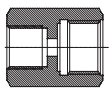
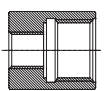
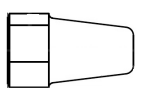
Type	Connection type	Quantity	Code no.
 <p>Weld nipple incl. union nut and O-ring</p>	CD 10	1 pc.	148B3729
 <p>Blind nut incl. gasket</p> <p>Blind nut SS incl. gasket</p>	G 1/2	1 pc.	148H3450
			148B4317
 <p>CD 6 Cutting ring + union nut</p> <p>CD 10 Cutting ring + union nut</p>	CD 6	1 pc.	148B4182
	CD 10	1 pc.	148B4183
		60 pcs.	148B4186
 <p>Welding nipple incl. aluminium gasket</p>	G½-ND6	2 pcs.	148B4184
 <p>Al gaskets included</p>	¼" FPT - ½" G	1 pc.	148B3860
 <p>Al gaskets included</p>	⅜" G - ½" G	1 pc.	148B3861
 <p>Seal cap & gasket</p>		1 pc.	148B4576

