

Technical brochure

High pressure float valve HFI



HFI is a high pressure float valve with internal liquid measuring device. The float valve is designed for direct flange mounting or welding on to plate heat exchanger type condensers, as illustrated in fig 1.

HFI is direct acting, therefore no differential pressure is required to activate the valve.

HFI is sturdy and reliable owing to its simple design. The float valve is equipped with a purge valve for purging non condensable gases e.g. air from the top of the valve housing. This facility is also useful if the valve has to be serviced.

The HFI is available with two external connections on the housing for drainage and pressure equalizations.

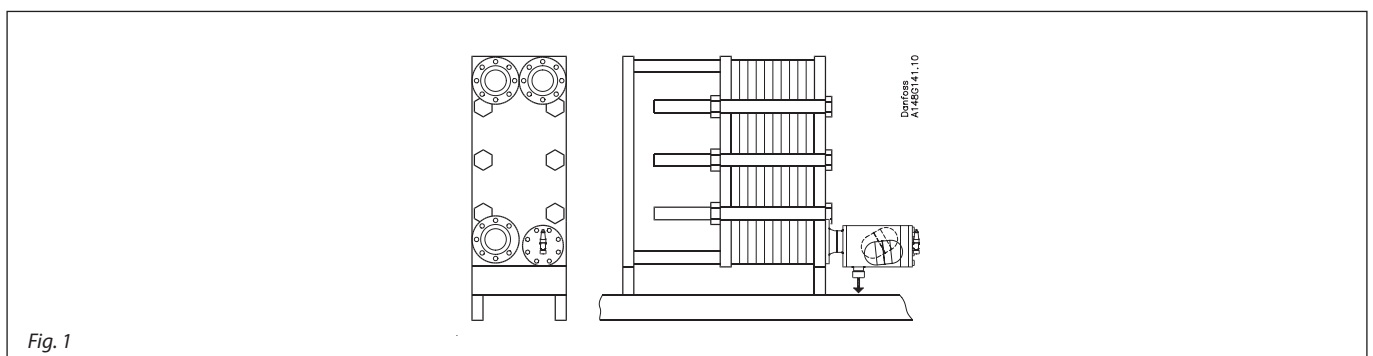

Fig. 1

Features

- Designed for direct flange mounting on to plate heat exchanger type condensers
- Can be mounted directly on vessels
- Temperature range: -50/+80°C (-58/+176°F)
- Equipped with purge valve for purging non condensable gasses
- Available with external connections for drainage and pressure equalizations
- Maximum operating pressure is 25 bar g (363 psi g)
- Suitable for R717 (ammonia), HCFC and HFC with a density of 500 through 700 kg/m³ (31.21 - 43.70 lb/ft³). For densities outside this range please contact your local Danfoss sales company.
- Housing i.e. shell and flange are made of special steel approved for low temperature application
- Classification: To get an updated list of certification on the products please contact your local Danfoss Sales Company.

High pressure float valve, HFI

Design

Available connections

Flange:
Inlet: Flange DN 100 or DN 150
(DIN-2635/DIN 2512-F)
Outlet: Welding connection DN 50 (EN 10220)

Butt-weld, DIN:

Inlet: DN 100 or DN 150 (EN 10220)
Outlet: Welding connection DN 50 (EN 10220)

Butt-weld, ANSI:

Inlet: DN 100 (4 in.) or DN 150 (6 in.)
(ANSI B 36.10)
Outlet: Welding connection DN 50 (2 in.)
(ANSI 36.10)

Housing

Housing i.e. shell and flange is made of special steel approved for low temperature operation.

Installation

Refer to installation instruction for HFI.

Identification:

MADE IN DENMARK CE 0045
Danfoss ANR0197.10

FLOAT VALVE TYPE: _____
HOUSING: TTS1 35N MAX PRES.: _____ BAR
P275 NL1 TEMPERATURE: -50 + 80 DEG.C
END COVER: P285GH / J4 REFRIGERANT: _____
DATE: _____

Pressure Equipment Directive (PED)

The HFI-valves are approved in accordance with the European standard specified in the Pressure Equipment Directive and are CE marked. For further details / restrictions - see Installation Instruction



HFI valves	
Nominal bore	DN 100 and 150 mm (4 in. and 6 in.)
Classified for	Fluid group I
Catagory	III

Technical data

- Refrigerants
Suitable for R717 (ammonia), HCFC and HFC with a density of 500 through 700 kg/m³ (31.21 - 43.70 lb/ft³). For densities outside this range please contact your local Danfoss sales company.
Flammable hydrocarbons are not recommended. For further information please contact your local Danfoss Sales Company.
- Temperature range
-50/+80°C (-58/+176 °F)

- Pressure
The float valve is designed for:
Maximum operating pressure:
25 bar g (363 psi g).
Strength test without float ball:
42 bar g (609 psi g).
Leakage test:
25 bar g (363 psi g).
Valves for higher pressure are available on request.

The principle of high pressure control

Introduction

In installations with one application high pressure control is an effective and cost saving way of expanding liquid from the condenser to the low pressure side.

High pressure refrigerant entering the condenser will start to condense, consequently condensate will accumulate at the bottom of the condenser and in the float valve.

When capacity demands increase, the liquid level in the float valve will rise, which will cause the valve to open and the refrigerant to expand into the separator at the low pressure side.

When the valve is closed, there will still be a small by-pass over the seat, so any remaining liquid will equalize slowly to the low pressure side, for instance during an off cycle. Therefore the system will equalize automatically and the compressor can start up without excessive back pressure. The size of the bypass is predetermined and defined by geometry of the elements.

It follows from the above, that almost all the refrigerant will be accumulated on the low pressure side under normal conditions. Therefore under normal conditions no high pressure receiver is necessary when using the HFI for high pressure control.

High pressure float valve, HFI

Insert for the high pressure float valve

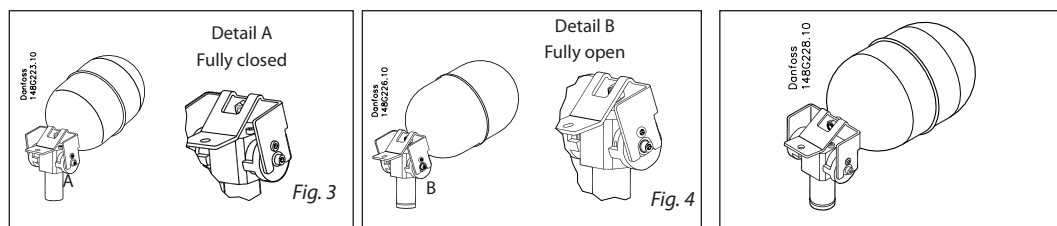

Computation and selection

In R 717 plants (ammonia)

On the following pages you will find tables with capacities of the float valve at various operating conditions.

Select a valve using the specific operating conditions. The chosen valve must have a capacity higher than the required capacity during nominal operation, as well as during plant start up.

In plants using other refrigerants than ammonia

The capacity of the float valve can be calculated by using the values and the equation to the right. However, the density of the refrigerant must be in the range: 500 to 700 kg/m³.

For densities outside this range please contact your local Danfoss Sales Company.

Valve type	Nominal capacity [kW] (R 717, -10/+35°C)	Valve constant [K]
HFI 040 FD	400	16.79
HFI 050 FD	800	33.58
HFI 060 FD	1200	50.36
HFI 070 FD	2400	100

$$\text{Mass flow } G = K\sqrt{\Delta p \times \rho} \text{ [kg/h]}$$

Δp = differential pressure [bar]

ρ = density of liquid [kg/m³]

K = valve constant (from the above table)

High pressure float valve, HFI

Computation and selection capacity tables - SI units

HFI 040 - R 717, evaporating capacity [kW]

Condensing temp. (°C)	Evaporating temperature (°C)												
	-40	-35	-30	-25	-20	-15	-10	-5	0	5	10	15	20
50	475	480	480	475	475	475	470	460	455	445	430	415	395
45	460	460	460	460	455	455	445	440	430	420	405	385	360
40	440	440	440	440	435	430	425	415	405	390	375	350	325
35	420	420	420	415	415	405	400	390	375	360	340	315	280
30	400	400	400	395	390	385	375	360	345	325	300	270	230
25	380	380	375	370	365	360	345	330	315	290	260	220	160
20	360	355	355	350	340	330	315	300	280	250	210	155	
15	340	335	330	325	315	300	285	265	240	200	150		
10	315	310	305	295	285	270	250	225	195	140			
5	290	285	280	270	255	240	215	185	135				
0	270	260	255	240	225	205	175	125					
-5	245	235	225	210	190	165	120						
-10	220	210	200	180	155	115							

HFI 050 - R 717, evaporating capacity [kW]

Condensing temp. (°C)	Evaporating temperature (°C)												
	-40	-35	-30	-25	-20	-15	-10	-5	0	5	10	15	20
50	955	955	955	955	950	945	935	925	910	890	865	830	790
45	920	920	920	915	910	905	895	880	860	835	805	770	725
40	880	880	880	875	870	860	850	830	810	780	745	700	645
35	845	845	840	835	825	815	800	780	755	720	680	625	560
30	805	800	800	790	780	765	750	725	695	655	605	540	455
25	765	760	755	745	730	715	695	665	630	580	520	440	320
20	720	715	705	695	680	660	635	600	555	500	420	310	
15	675	670	660	645	630	605	570	530	480	405	295		
10	630	625	610	595	570	545	505	455	385	285			
5	585	575	560	540	515	480	430	365	270				
0	540	525	505	485	450	405	345	255					
-5	490	475	455	425	385	325	240						
-10	440	420	395	360	305	230							

HFI 060 - R 717, evaporating capacity [kW]

Condensing temp. (°C)	Evaporating temperature (°C)												
	-40	-35	-30	-25	-20	-15	-10	-5	0	5	10	15	20
50	1430	1435	1435	1430	1425	1420	1405	1385	1365	1335	1295	1245	1190
45	1380	1380	1380	1375	1370	1360	1340	1320	1290	1255	1210	1155	1085
40	1325	1325	1320	1315	1305	1290	1270	1245	1215	1170	1120	1055	970
35	1265	1265	1260	1250	1240	1220	1200	1170	1130	1080	1020	940	840
30	1205	1205	1195	1185	1170	1150	1120	1085	1040	980	905	810	685
25	1145	1140	1130	1115	1100	1075	1040	995	940	870	780	660	485
20	1080	1070	1060	1045	1020	990	950	900	835	750	635	465	
15	1015	1005	990	970	940	905	860	795	715	605	445		
10	945	935	915	890	860	815	755	680	580	425			
5	875	860	840	810	770	720	645	550	405				
0	805	785	760	725	675	610	520	380					
-5	735	710	680	635	575	490	360						
-10	660	635	595	540	460	340							

HFI 070 - R717, evaporating capacity [kW]

Condensing temp. (°C)	Evaporating temperature (°C)												
	-40	-35	-30	-25	-20	-15	-10	-5	0	5	10	15	20
50								2775	2725	2665	2590	2495	2375
45							2680	2640	2580	2510	2420	2310	2170
40							2545	2490	2425	2340	2235	2105	1940
35						2445	2400	2335	2260	2160	2035	1880	1680
30					2340	2300	2245	2170	2080	1960	1815	1625	1370
25					2195	2145	2080	1995	1885	1745	1565	1320	965
20				2090	2040	1980	1900	1800	1670	1500	1265	930	
15				1940	1885	1810	1715	1595	1435	1210	890		
10			1835	1785	1715	1630	1515	1365	1160	850			
5		1725	1680	1620	1540	1435	1295	1100	810				
0		1575	1520	1450	1350	1220	1040	765					
-5	1470	1425	1360	1270	1150	980	725						
-10	1325	1265	1190	1080	920	685							

High pressure float valve, HFI

Computation and selection capacity tables - US units

HFI 040 - R 717, evaporating capacity [TR]

Condensing temp. (°F)	Evaporating temperature (°F)												
	-40	-30	-20	-10	0	10	20	30	40	50	60	70	80
120	134	135	135	134	134	132	131	128	125	121	116	109	101
110	129	129	129	128	127	126	123	121	117	112	106	98	87
100	123	123	122	122	120	118	116	112	108	102	94	84	71
90	117	117	116	115	113	111	107	103	98	91	81	69	50
80	110	110	109	107	105	102	99	94	87	78	66	49	
70	103	103	102	100	97	94	89	83	75	63	47		
60	97	96	94	92	89	84	79	71	60	44			
50	90	88	86	83	80	74	67	57	42				
40	82	81	78	75	70	63	54	40					
30	75	73	70	65	59	51	38						
20	67	65	61	55	47	35							
10	59	56	51	44	33								

HFI 050 - R 717, evaporating capacity [TR]

Condensing temp. (°F)	Evaporating temperature (°F)												
	-40	-30	-20	-10	0	10	20	30	40	50	60	70	80
120	268	269	269	269	267	265	261	256	250	242	231	218	201
110	258	258	257	256	254	251	247	241	233	224	211	195	175
100	246	246	245	243	241	237	232	224	215	204	189	169	143
90	234	233	232	229	226	221	215	207	196	181	163	138	101
80	221	220	218	215	211	205	197	187	174	156	132	97	
70	207	206	203	200	194	187	178	166	149	127	93		
60	193	191	188	184	177	169	157	142	121	89			
50	179	176	172	167	159	149	134	114	84				
40	165	161	156	149	140	127	108	80					
30	150	145	139	130	118	102	75						
20	135	129	121	110	95	70							
10	119	112	102	88	65								

HFI 060 - R 717, evaporating capacity [TR]

Condensing temp. (°F)	Evaporating temperature (°F)												
	-40	-30	-20	-10	0	10	20	30	40	50	60	70	80
120	403	404	404	403	401	397	392	385	375	363	347	327	302
110	386	387	386	384	381	377	370	362	350	335	317	293	262
100	369	368	367	365	361	355	347	337	323	305	283	253	214
90	350	350	348	344	339	332	322	310	293	272	244	207	151
80	331	329	327	322	316	307	296	281	261	234	199	146	
70	310	309	305	299	292	281	267	249	224	190	140		
60	290	287	282	275	266	253	236	213	181	133			
50	269	265	259	250	239	223	202	172	126				
40	247	242	234	224	209	190	162	120					
30	225	218	209	196	178	152	113						
20	202	194	182	165	142	106							
10	178	168	153	132	98								

HFI 070 - R717, evaporating capacity [TR]

Condensing temp. (°F)	Evaporating temperature (°F)												
	-40	-30	-20	-10	0	10	20	30	40	50	60	70	80
120							784	769	750	725	694	654	603
110							741	723	700	671	633	586	524
100						710	695	673	646	611	566	507	428
90					678	664	645	620	587	544	489	413	302
80					632	615	592	561	521	469	397	292	
70				599	583	562	534	497	447	380	279		
60				551	532	506	472	426	362	267			
50			517	500	477	446	403	343	253				
40		483	469	448	419	380	325	240					
30		436	418	391	355	305	226						
20	404	387	364	331	284	211							
10	357	336	307	263	195								

High pressure float valve, HFI

High pressure control in refrigeration system with condenser/evaporator

Fig. 5 shows a water chiller with plate heat exchanger as both condenser and evaporator. HFI is flanged directly on to the condenser.

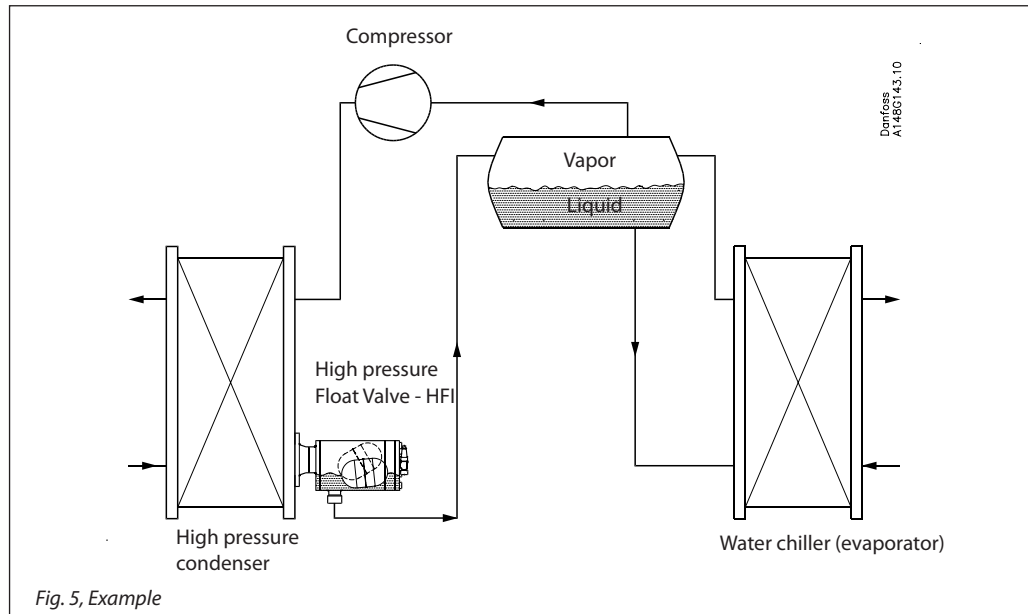

High pressure float valve, HFI

Material specification

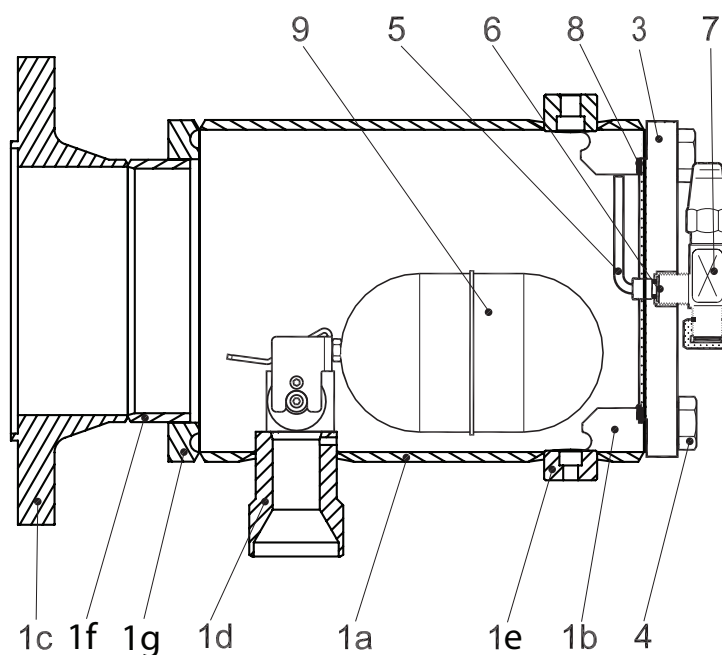

Fig. 6

No	Part	Material	DIN/EN	ASTM
1	Housing: a. Shell b. Flange (shell) c. Flange (inlet) d. Branch (discharge) e. External connection f. Flange (shell) g. Connecting tube	Steel Steel Steel Steel Steel Steel Steel	TTSt35N, DIN17173 P275 NL1, EN10028-3 P285QH EN 10222-4 P275 NL1, EN10028-3 P285QH EN 10222-4 TTSt35N, DIN17173 P275 NL1, EN10028-3	Grade 1, A333, A334 Grade A, A662 LF2A350 Grade A, A662 LF2A350 Grade 1, A333, A334 Grade A, A662
3	End cover with cylinder	Steel	P275 NL1, EN 10 028-3	
4	Set screw	Stainless steel	A2-70	
5	Tube	Steel		
6	Gasket	Aluminium		
7	Purge valve, SNV-ST ¹⁾			
8	Gasket	Non asbestos		
9	Float Ball	Steel		

¹⁾ for further information please see the technical brochure for SNV-ST valves.

High pressure float valve, HFI

Connections

DIN - Outlet

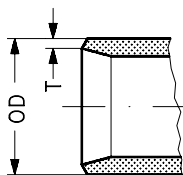

Butt welding EN10220

Size mm	Size in.	Outlet				For use with valve type
		OD mm	T mm	OD in.	T in.	
100	4	60.3	2.9	2.37	0.11	HFI 040 HFI 050 HFI 060 HFI 070
150	6	60.3	2.9	2.37	0.11	HFI 050 HFI 060 HFI 070

ANSI - Outlet

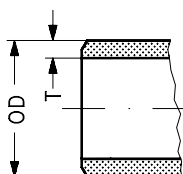

Butt welding ANSI B 36.10

Size mm	Size in.	Outlet				For use with valve type
		OD mm	T mm	OD in.	T in.	
100	4	60.3	3.9	2.37	0.11	HFI 040 HFI 050 HFI 060 HFI 070
150	6	60.3	3.9	2.37	0.11	HFI 050 HFI 060 HFI 070

DIN - Inlet

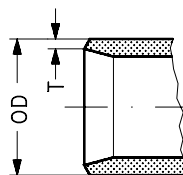

Butt welding EN 10220

Size mm	Size in.	Inlet				For use with valve type
		OD mm	T mm	OD in.	T in.	
100	4	114.3	3.6	4.50	0.14	HFI 040 HFI 050 HFI 060 HFI 070
150	6	168.3	4.5	6.63	0.18	HFI 050 HFI 060 HFI 070

ANSI - Inlet

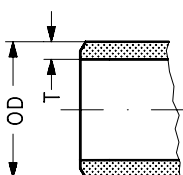

Butt welding ANSI B 36.10

Size mm	Size in.	Inlet				For use with valve type
		OD mm	T mm	OD in.	T in.	
100	4	114.3	6.3	4.50	0.14	HFI 040 HFI 050 HFI 060 HFI 070
150	6	168.3	7.1	6.63	0.18	HFI 050 HFI 060 HFI 070

Inlet flange

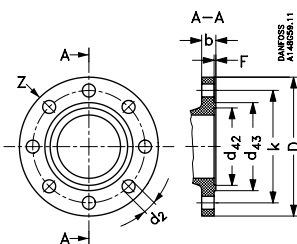

40 bar / DIN 2635 / DIN 2512-F*

		D	b	k	d ₄₂	d ₄₃	F	d ₂	Z
Size 100 (4 in.)	mm	235	24	190	129	149	4.5	22	8 pcs.
	in.	9.3	0.94	7.48	5.08	5.87	0.18	0.97	
Size 150 (6 in.)	mm	300	28	250	183	203	4.5	26	8 pcs.
	in.	11.8	1.10	9.84	7.20	7.99	0.18	1.02	

*Inlet flange and DIN outlet

High pressure float valve, HFI

Dimensions and weights

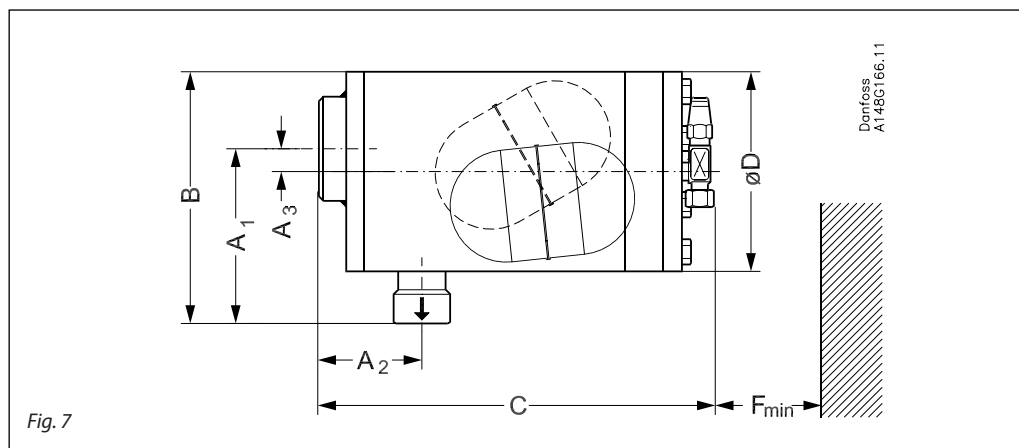

High pressure float valve without flange (Fig. 7)

Valve size		A ₁	A ₂	A ₃	B	C	ØD	F _{min.}	Weight
HFI 100	mm	192	113	25	276	435	219	200	37 kg
	in.	7.56	4.45	0.98	10.87	17.13	8.62	7.87	81.5 lb
HFI 150	mm	167	113		276	435	219	200	37 kg
	in.	6.57	4.45		10.87	17.13	8.62	7.87	81.5 lb

Specified weights are approximate values only.

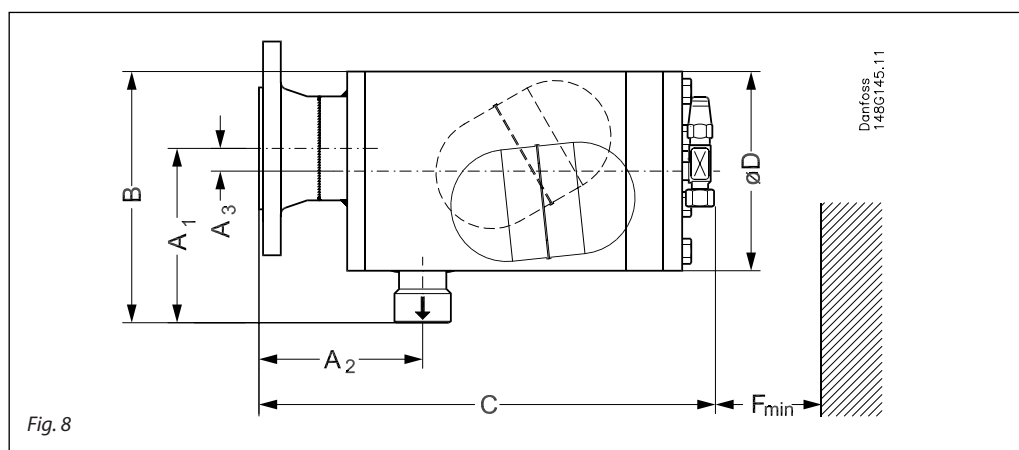

High pressure float valve with flange (Fig. 8)

Valve size		A ₁	A ₂	A ₃	B	C	ØD	F _{min.}	Weight
HFI 100	mm	192	180	25	309	502	219	200	41 kg
	in.	7.56	7.09	0.98	12.17	19.76	8.62	7.87	90.4 lb
HFI 150	mm	167	189		317	511	219	200	41 kg
	in.	6.57	7.44		12.48	20.12	8.62	7.87	90.4 lb

Specified weights are approximate values only.

High pressure float valve, HFI

Dimensions and weights (HFI with external connections)

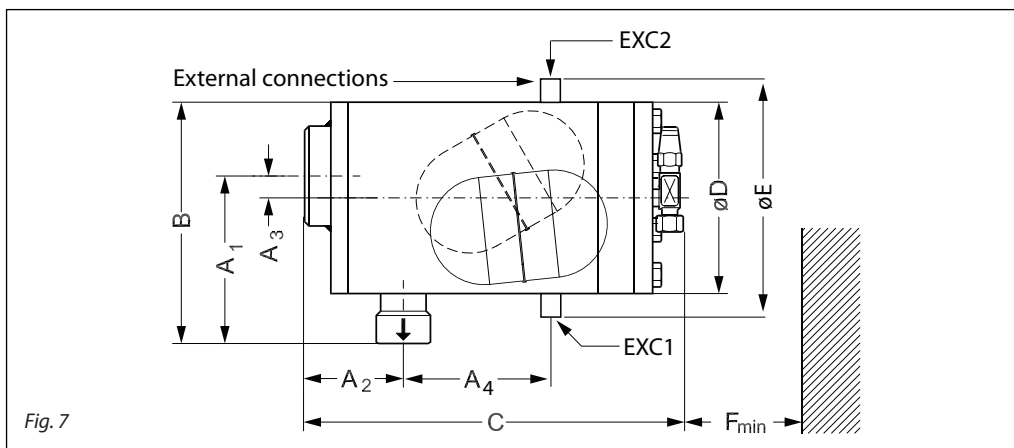

High pressure float valve without flange (Fig. 7)

Valve size		A ₁	A ₂	A ₃	A ₄	B	C	øD	øE	F _{min.}	Weight
HFI 100	mm	192	113	25	176	276	435	219	247	200	37 kg
	in.	7.56	4.45	0.98	6.93	10.87	17.13	8.62	9.72	7.87	81.5 lb
HFI 150	mm	167	113		176	276	435	219	247	200	37 kg
	in.	6.57	4.45		6.93	10.87	17.13	8.62	9.72	7.87	81.5 lb

Specified weights are approximate values only.

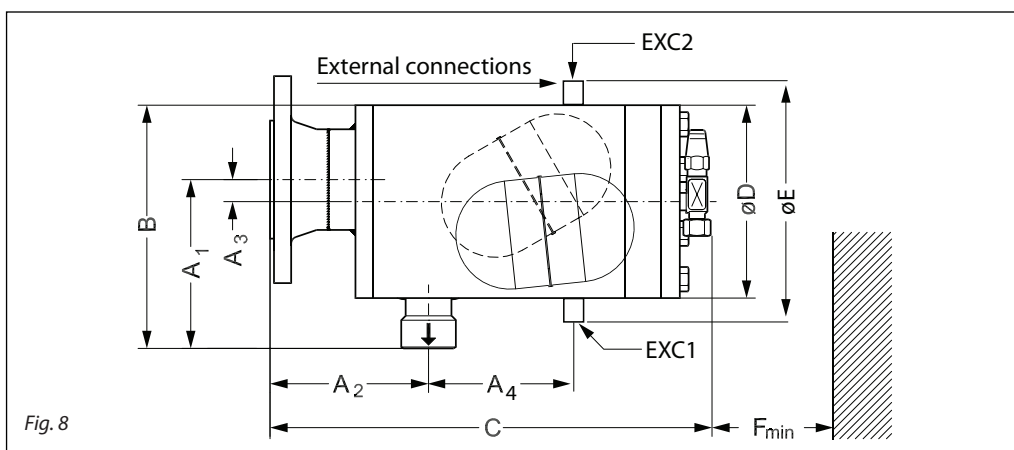

High pressure float valve with flange (Fig. 8)

Valve size		A ₁	A ₂	A ₃	A ₄	B	C	øD	øE	F _{min.}	Weight
HFI 100	mm	192	180	25	176	309	502	219	247	200	41 kg
	in.	7.56	7.09	0.98	6.93	12.17	19.76	8.62	9.72	7.87	90.4 lb
HFI 150	mm	167	189		176	317	511	219	247	200	41 kg
	in.	6.57	7.44		6.93	12.48	20.12	8.62	9.72	7.87	90.4 lb

Specified weights are approximate values only.

EXC1	3/8 - 18 NPT
EXC2	1/2 - 14 NPT

High pressure float valve, HFI

Volumes

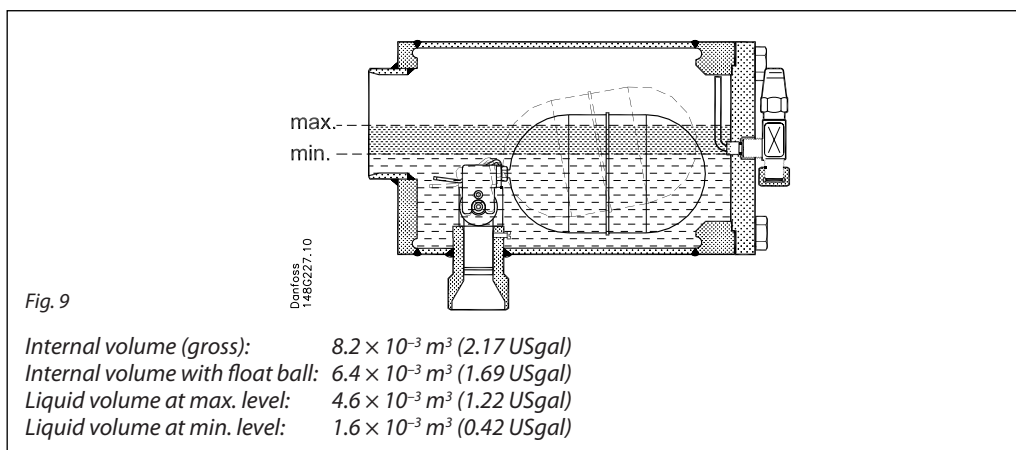

Ordering

The table below is used to identify the valve required.

Example: HFI 040 D 100 = 148G3092

Type	Inlet connection size	Nozzle size	Code numbers
HFI 040 FD 100	100 (4 in.) DIN Flange	40	148G3102
HFI 050 FD 100		50	148G3103
HFI 060 FD 100		60	148G3104
HFI 070 FD 100		70	148G3422
HFI 050 FD 150	150 (6 in.) DIN Flange	50	148G3105
HFI 060 FD 150		60	148G3106
HFI 070 FD 150		70	148G3423
HFI 040 D 100	100 (4 in.) DIN BW	40	148G3092
HFI 050 D 100		50	148G3093
HFI 060 D 100		60	148G3094
HFI 070 D 100		70	148G3418
HFI 050 D 150	150 (6 in.) DIN BW	50	148G3095
HFI 060 D 150		60	148G3096
HFI 070 D 150		70	148G3419
HFI 040 A 100	100 (4 in.) ANSI BW	40	148G3097
HFI 050 A 100		50	148G3098
HFI 060 A 100		60	148G3099
HFI 070 A 100		70	148G3420
HFI 050 A 150	150 (6 in.) ANSI BW	50	148G3100
HFI 060 A 150		60	148G3101
HFI 070 A 150		70	148G3421

HFI with 2 external connections

Type	Inlet connection size	Nozzle size	Code numbers
HFI 040 FD 100 w. 2 ext. con	100 (4 in.) DIN Flange	40	148G3196
HFI 050 FD 100 w. 2 ext. con		50	148G3727
HFI 060 FD 100 w. 2 ext. con		60	148G3670
HFI 070 FD 100 w. 2 ext. con		70	148G3671
HFI 050 FD 150 w. 2 ext. con	150 (6 in.) DIN Flange	50	148G3762
HFI 060 FD 150 w. 2 ext. con		60	148G3763
HFI 070 FD 150 w. 2 ext. con		70	148G3764
HFI 040 D 100 w. 2 ext. con	100 (4 in.) DIN BW	40	148G3765
HFI 050 D 100 w. 2 ext. con		50	148G3704
HFI 060 D 100 w. 2 ext. con		60	148G3766
HFI 070 D 100 w. 2 ext. con		70	148G3720
HFI 050 D 150 w. 2 ext. con	150 (6 in.) DIN BW	50	148G3767
HFI 060 D 150 w. 2 ext. con		60	148G3768
HFI 070 D 150 w. 2 ext. con		70	148G3769

FD = inlet flange DIN
 D = Butt welding DIN
 A = Butt welding ANSI

Insert for HFI 070 (complete insert with float ball - without float housing)	148G3584
Insert for HFI 60 (complete insert with float ball - without float housing)	148G3663
Insert for HFI 50 (complete insert with float ball - without float housing)	148G3662
Insert for HFI 40 (complete insert with float ball - without float housing)	148G3661

