

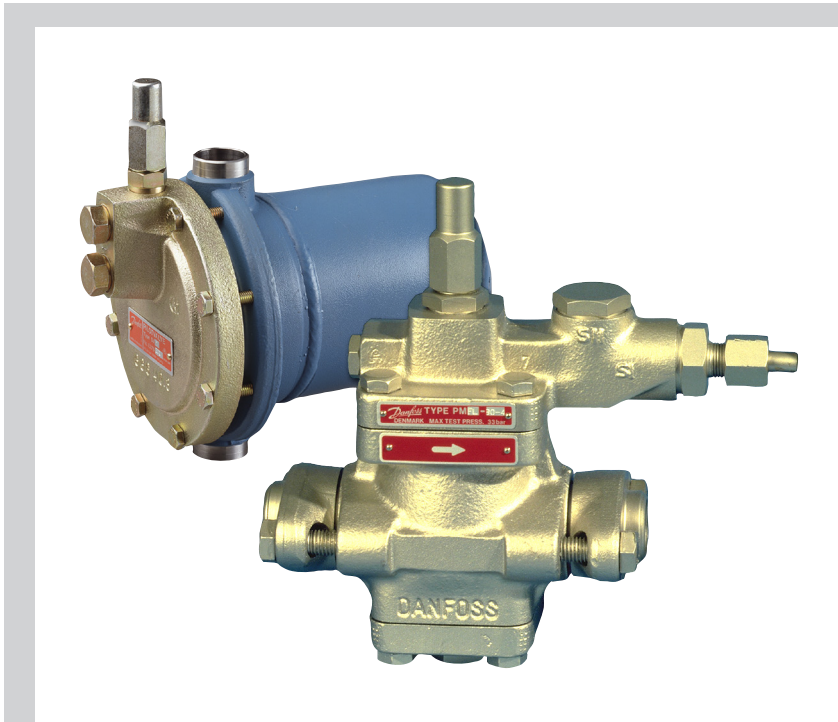

Technical brochure

Modulating liquid level regulators, servo-controlled PMFL / PMFH and SV



For modulating liquid level control in refrigeration, freezing and air conditioning plant, a system comprising a modulating servo-controlled main expansion valve type PMFL or PMFH, controlled by a pilot float valve type SV, is used.

PMFL and SV systems are used on the evaporator side. PMFH and SV systems are used on the condenser side. The system is suitable for use with ammonia or fluorinated refrigerants. The PMFL and PMFH can be used in liquid lines to or from

- evaporators
- separators
- intermediate coolers
- condensers
- receivers

Modulating liquid level regulation provides liquid injection that is proportional to the actual capacity. This gives a constant amount of flashgas, thus ensuring stable regulation and economic operation because variations in pressure and temperature are held to a minimum.

Features

- Applicable to HCFC, HFC and R717 (Ammonia).
- PMFL/PMFH are based on PM valve family housings
- Same flange programme as for PM valve series
- Valve housing in low temperature cast iron (spherical) - EN GJS 400-18-LT
- Manual operation possible
- Position indicator available
- Pressure gauge connection to monitor inlet pressure
- Simple installation
- Main valve top cover can be located in any position without affecting the function

Approvals

Pressure Equipment Directive (PED)
The PMFL / PMFH valves are approved and CE marked in accordance with Pressure Equipment

Directive - 97/23/EC.
For further details / restrictions - see Installation Instruction.



PMFL/PMFH-valves*			
Nominal bore	DN ≤ 25 (1 in.)	DN 32-125 mm (1 1/4 - 5 in.)	DN 150 mm (6 in.)
Classified for	Fluid group I		
Catagory	Article 3, paragraph 3	II	III

* CE is only applicable to the EN GJS 400-18-LT

Modulating liquid level regulators, servo-controlled, type PMFL / PMFH and SV

Technical data

Refrigerants

Applicable to HCFC, HFC and R717 (Ammonia).

Max. working pressure

PMFL / H: MWP = 28 bar

SV: MWP = 28 bar

Max. test pressure

PMFL / H: Max. test pressure = 42 bar

SV: Max. test pressure = 42 bar

Temperature of media:

-60°C to +120°C.

Note:

Max. working pressure is limited to MWP = 21 bar when media temperatures are: below -20°C for valves made of GGG-40.3 and below -10°C for valves made of GG-25.

Modulating liquid level regulators, servo-controlled, type PMFL / PMFH and SV

Design/Function

PMFL

- 6. Seal plug
- 10. Valve spindle
- 12. Valve seat
- 19. Valve body
- 19a. Channel in valve body
- 20. Bottom cover
- 23. Main spring
- 24. Servo piston
- 24a. Channel in servo piston
- 30. Top cover
- 30a.b.c. Channels in top cover
- 31. Valve cone
- 43. Supplementary spring
- 44. Manometer connection
- 53. Spindle cap
- 60. Setting spindle
- 73. Pilot connection

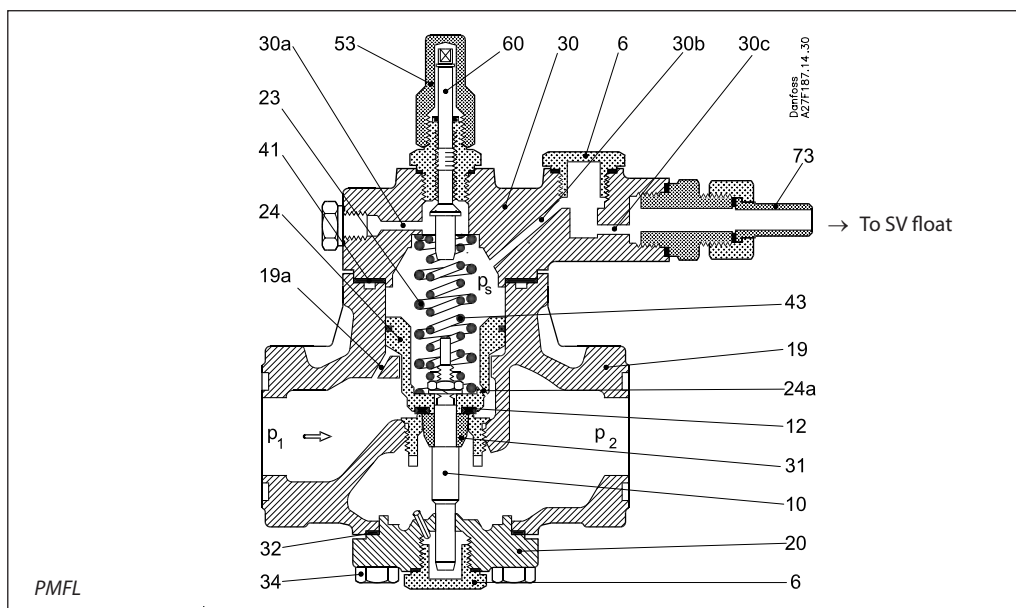

When the liquid level inside the float drops, the float orifice opens. This relieves the higher pressure, p_s , acting on the servo piston to the low pressure side causing the PMFL to open. Variations in liquid level will result in variations

in pressure over the piston and variation in the amount of liquid injected. It is important to choose the correct spring set when designing the plant. The spring set should be selected from the table below:

Subcooling		Pressure difference over main valve			
		bar	psi	bar	psi
K	F	4 - 15	58 - 218	1.2 - 4.0	17 - 58
0 - 8	0 - 14	Normal spring set		Weak spring set	
8 - 40	14 - 72	Strong spring set			

The setting spindle, pos. 60, has not been set from factory. It is imperative that the setting spindle is adjusted before the valve is put into operation. The outer spring, pos. 23, is preset and the inner spring, pos. 43, is adjusted when

turning the spindle. The following tables shows the adjustment of the inner spring in number of turns of the spindle as a function of valve size, spring type and pressure difference:

PMFL	C/w normal (factory mounted) spring set, subcooling 0-8 K ~ 0-14 F				
	Pressure difference (Δp) over PMFL in bar or psi				
	< 5 bar	5 - 8 bar	8 - 10 bar	10 - 12 bar	> 12 bar
	< 72 psi	72 - 116 psi	116 - 145 psi	145 - 174 psi	> 174 psi
80	No tension	2 - 3	3 - 4.5	4.5 - 6	ca. 7
125	No tension	3 - 5	5 - 7	7 - 9	ca. 10
200	No tension	3 - 5	5 - 7	7 - 9	ca. 10
300	No tension	4 - 6	6 - 9	9 - 12	ca. 14

PMFL	C/w strong spring set, subcooling 8-40 K ~ 14-72 F	
	Pressure difference (Δp) over PMFL in bar or psi	
	6 - 9 bar	> 9 bar
	87 - 131 psi	> 131 psi
80	4	Max. tension
125	6	Max. tension

PMFL	C/w strong spring set, subcooling 8-40 K ~ 14-72 F	
	Pressure difference (Δp) over PMFL in bar or psi	
	6 - 16 bar	
	87 - 232 psi	
200	Spring must always be set to max. tension	
300		

PMFL	C/w weak spring set, low pressure plants			
	Pressure difference (Δp) over PMFL in bar or psi			
	1.2 - 1.8 bar	1.8 - 2.5 bar	2.5 - 3 bar	3 - 4 bar
	17 - 26 psi	26 - 36 psi	36 - 43 psi	43 - 58 psi
80	No tension	3 - 4	4 - 6	Max. tension
125	No tension	4 - 6	6 - 8	Max. tension
200	No tension	4 - 6	6 - 8	Max. tension
300	No tension	5 - 7	5 - 7	Max. tension

Design/Function
(continued)

The values for spindle turns are an indication for an initial setting only. If a position indicator is used, a more precise modulation can be achieved when fine tuning the valve setting. If the PMFL is not opening fully, the spring tension must be reduced. If the PMFL is operating in a ON/OFF function, the spring tension should be increased. The condenser pressure will have an effect on the fine tuning and large variations in condensing pressure might call for readjustment. The subcooling is measured just before the PMFL and the pressure difference is for the valve only excluding piping and armatures.

The PMFL can be used together with SV 4 as a pilot valve.

The orifices determines the k_v (C_v) value of the pilot and the following table can be used as an initial selection guide:

PMFL	SV 4-6	
	Ø 2.5	Ø 3 (SV 4)
80	X	
125	X	
200	X	
300		X

The final choice of orifice may vary depending on refrigerant and pressure levels. Smaller pressure levels needs a bigger orifice. Pressure difference levels below 3 bar (43 psi) need SV 4-6 with Ø3 mm orifice.

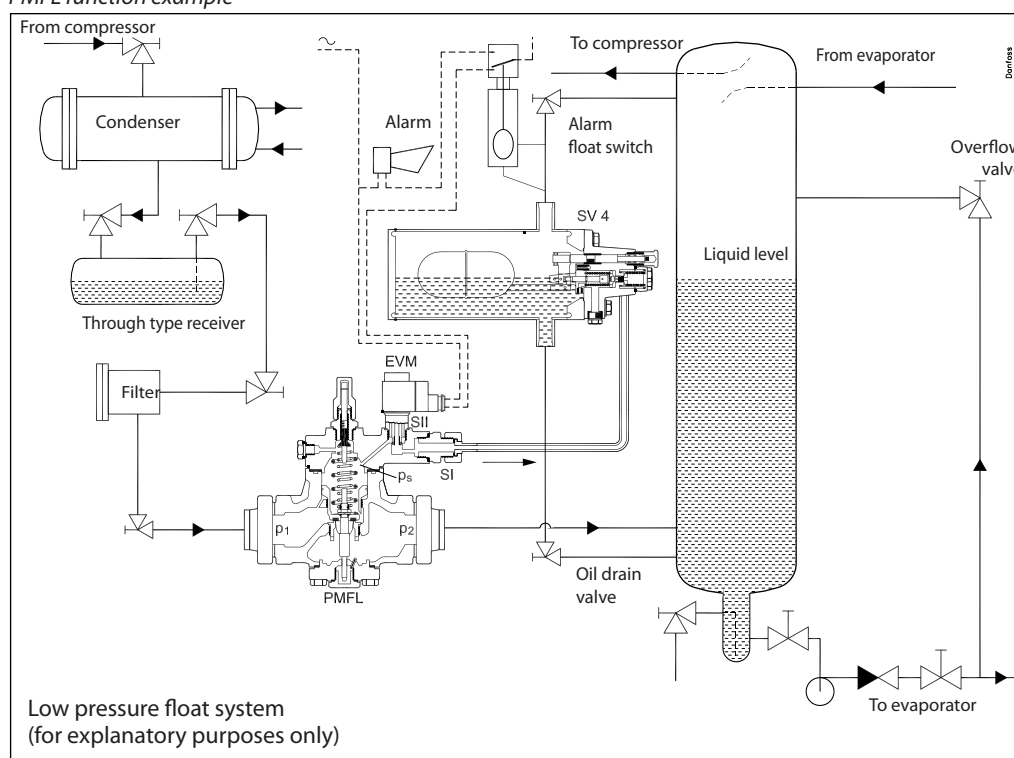
PMFL function example

SV floats for PMFL

SV 4 can be used for PMFL low pressure control system. the float must be connected as shown.

P-port:

When using the P-port, it is possible to force open the PMFL valve to a fully open position. This is practical for service purposes or to confirm if the float has sufficient capacity for the PMFL and the operating conditions. However, when P-port connection is used it is possible to overfill a system due to constant bleeding or unauthorised tampering. In this case, its advisable to introduce a shut off when the liquid level reaches a preset point. Shut off can be done via an electrical switch if an EVM valve is mounted in the SII port in the top of the PMFL. It is only advisable to use the P-port connection at low subcooling, < 8 K (< 14 F).

In general:

- If the float system is unstable, set a larger bleed.
- If the PMFL stays open when the float is closed, set a smaller bleed.

S-port:

The S-port offers the advantage of a preorifice which divides the pressure drop and any wear possibility due to cavitation. S-port connection must be used if the subcooling is higher than 8 K (14 F). The spindle should be opened 4 turns initially before adjustment. Adjustment should be done in steps of ¼ turn until the PMFL has a modulating function. The k_v (C_v) value of the SV is higher using P-port than using S-port. A higher P-band can thus be obtained.

Modulating liquid level regulators, servo-controlled, type PMFL / PMFH and SV

Design/Function

(Continued)

PMFH

- 3. Manometer connection
- 6. Seal plug
- 10. Valve spindle
- 19. Valve body
- 19a. Channel in valve body
- 20. Bottom cover
- 21a. Channel in servo piston
- 23. Main spring
- 24. Servo piston
- 30. Top cover
- 30a.b.c. Channels in top cover
- 31. Valve cone
- 53. Spindle cap
- 60. Manual opening
- 73. Pilot connection

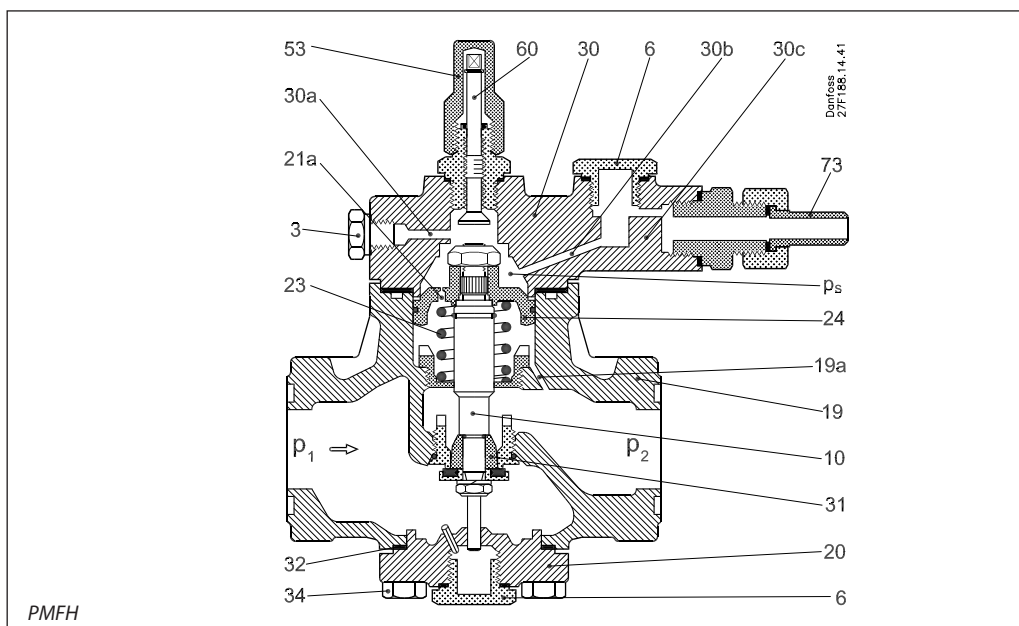

If the liquid level inside the SV float rises, the float orifice opens and relieves pressure through the pilot line to the top of the PMFH, increasing the pressure, p_s , moving the pushrod downwards and opening the PMFH. The pilot line is connected in the topcover at SI. Override of the pilot signal can be made by using an EVM valve at SII. It is important to choose the correct spring set when designing the plant. The spring set should be selected from the table below:

The PMFH can be used together with either SV 1 or 3 with the SV mounted with the bleed valve downwards, refer to the drawing below. This reverses the opening so that rising float opens the orifice.

Pressure difference over main valve			
bar	psi	bar	psi
0 - 4.5	0 - 65	> 4.5	> 65
Weak spring set		Normal spring set	

PMFH function example

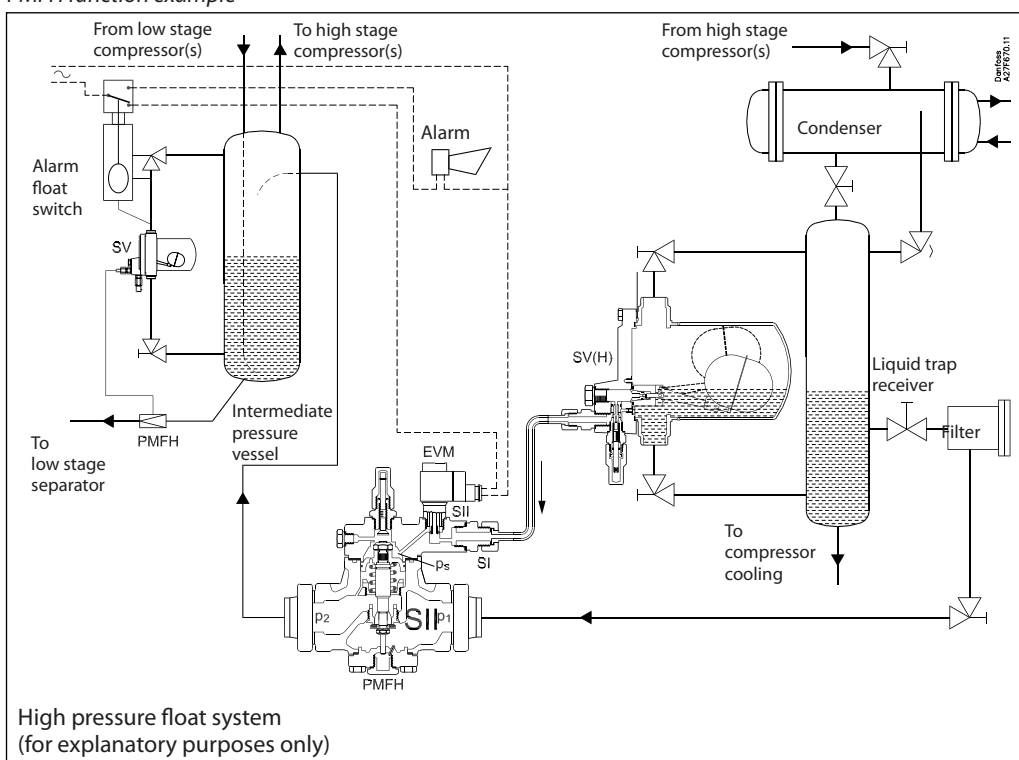

Modulating liquid level regulators, servo-controlled, type PMFL / PMFH and SV

Design/Function (Continued)

SV 1-3 float has 2 different pilot connections: S-port (series connection with PMFH) or P-port (parallel connection with the PMFH).

a preset point. Shut off can be done via an electrical switch if an EVM valve is mounted in the SII port in the top of the PMFH. It is only advisable to use the P-port at low pressure difference.

SV 1-3

P-port:

When using the P-port, it is possible to force open the PMFH valve to a fully open position. This is practical for service purposes or to confirm if the float has sufficient capacity for the PMFH and the operating conditions. However, when P-port connection is used it is possible to overfill a system due to constant bleeding or unauthorised tampering. In this case, it is advisable to introduce a shut off when the liquid level reaches

S-port:

The S-port offers the advantage of a preorifice which divides the pressure drop and any wear possibility due to cavitation. S-port connection must be used at high pressure differences, $dp > 10$ bar (145 psi). The k_v (C_v) value of the SV is higher using P-port than using S-port. A higher P-band can thus be obtained.

Sizing

Sizing example for PMFL

Refrigerant
R 717 (NH₃)

Evaporator capacity
 $Q_e = 600$ kW

Evaporating temperature
 $t_e = -10^\circ\text{C}$ ($\sim p_e = 2.9$ bar abs.)

Condensing temperature
 $t_c = +30^\circ\text{C}$ ($\sim p_c = 11.9$ bar abs.)

Liquid temperature ahead of valve
 $t_l = +20^\circ\text{C}$ at max. capacity

Subcooling
 $\Delta t_{\text{sub}} = t_c - t_l = 30^\circ\text{C} - 20^\circ\text{C} = 10$ K
Calculations do not take into account pressure loss in pipelines.

Pressure drop across valve
 $\Delta p = p_c - p_e = 11.9$ bar $- 2.9$ bar = 9 bar

Correction factor for 10 K subcooling
0.98

Corrected capacity
 600 kW $\times 0.98 = 588$ kW

The corrected capacity can be found in the capacity table. It will be seen from the table that valve type PMFL 80-4 should be chosen. Referring to "ordering table", code number **027F0053** can be found.

For details of flanges, accessories and pilot valve, see the ordering table.

Since $\Delta p = 9$ bar and $\Delta t_{\text{sub}} = 10$ K, it will be seen from the "C/w strong spring set" for PMFL that a "STRONG" spring set must be used. The pilot line is connected to SV at connection S. In the ordering table the code number for the spring set can be found: **027F0118**.

Sizing example for PMFH

Refrigerant
R 717 (NH₃)

Evaporator capacity
 $Q_e = 2200$ kW

Evaporating temperature
 $t_e = -10^\circ\text{C}$ ($\sim p_e = 2.9$ bar abs.)

Condensing temperature
 $t_c = +30^\circ\text{C}$ (~ 11.9 bar abs.)

Liquid temperature ahead of valve
 $t_l = +20^\circ\text{C}$

Subcooling
 $\Delta t_{\text{sub}} = t_c - t_l = 30^\circ\text{C} - 20^\circ\text{C} = 10$ K
Calculations do not take into account pressure loss in pipelines.

Pressure drop across valve
 $\Delta p = p_c - p_e = 11.9$ bar $- 2.9$ bar = 9 bar

Correction factor for 10 K subcooling
0.98

Corrected capacity
 2200 kW $\times 0.98 = 2156$ kW

The corrected capacity can be found in the capacity table. It will be seen from the table that valve type PMFH 80-7 should be chosen. In the ordering table the code number for the valve can be found: **027F3060** for CE-approved valve.

For details of flanges, accessories and pilot valve, see the ordering table.

Correction factors

When dimensioning, multiply the evaporator capacity by a correction factor k dependent on

the subcooling Δt_{sub} just ahead of the valve. The corrected capacity can then be found in the capacity table.

R 717 (NH₃)

Δt K	2	4	10	15	20	25	30	35	40	45	50
k	1.01	1.00	0.98	0.96	0.94	0.92	0.91	0.89	0.87	0.86	0.85

R 22

Δt K	2	4	10	15	20	25	30	35	40	45	50
k	1.01	1.00	0.96	0.93	0.90	0.87	0.85	0.83	0.80	0.78	0.77

Modulating liquid level regulators, servo-controlled, type PMFL / PMFH and SV
Capacity in kW

Type	Evaporating temperature t _e °C	Rated capacity in kW at pressure drop across valve Δp bar			
		0.8	1.2	1.6	2.0

R 717 (NH₃)

PMFL 80-1	+10	50	60	69	76
	0	51	62	71	79
	-10	53	64	73	81
	-20	54	65	74	82
	-30	55	66	75	83
	-40	56	67	79	86
-50	56	67	75	82	
PMFL 80-2	+10	80	97	111	123
	0	83	101	115	127
	-10	85	103	118	130
	-20	86	105	119	132
	-30	88	106	120	133
	-40	89	107	120	132
-50	90	106	119	131	
PMFL 80-3	+10	127	154	176	194
	0	131	159	182	201
	-10	134	163	186	205
	-20	137	164	188	207
	-30	139	167	188	207
	-40	140	166	187	205
-50	139	164	184	201	
PMFL 80-4	+10	206	250	286	316
	0	214	259	295	327
	-10	219	264	301	333
	-20	222	267	303	334
	-30	224	267	301	330
	-40	223	263	295	323
-50	219	257	288	315	
PMFL 80-5	+10	325	394	449	496
	0	336	406	463	511
	-10	344	413	470	518
	-20	347	414	468	514
	-30	345	407	458	502
	-40	338	396	444	486
-50	327	383	429	470	
PMFL 80-6	+10	565	682	773	851
	0	584	700	792	869
	-10	591	705	795	871
	-20	587	692	777	850
	-30	571	666	746	816
	-40	546	636	712	781
-50	520	608	684	751	
PMFL 80-7	+10	881	1060	1190	1300
	0	909	1080	1210	1310
	-10	910	1070	1190	1300
	-20	887	1030	1150	1250
	-30	844	975	1090	1190
	-40	794	921	1030	1130
-50	750	875	984	1080	
PMFL 125	+10	1400	1690	1910	2100
	0	1450	1730	1950	2140
	-10	1460	1740	1950	2140
	-20	1450	1700	1930	2080
	-30	1400	1630	1820	1990
	-40	1330	1550	1730	1900
-50	1260	1480	1660	1830	
PMFL 200	+10	2250	2710	3060	3360
	0	2320	2770	3120	3420
	-10	2340	2780	3120	3410
	-20	2310	2710	3030	3310
	-30	2220	2590	2890	3160
	-40	2110	2480	2750	3020
-50	2000	2340	2630	2900	
PMFL 300	+10	3420	4110	4650	4990
	0	3530	4210	4740	5180
	-10	3560	4210	4730	5170
	-20	3500	4100	4590	5010
	-30	3370	3910	4370	4780
	-40	3190	3710	4160	4560
-50	3030	3540	3980	4380	

Type	Evaporating temperature t _e °C	Rated capacity in kW at pressure drop across valve Δp bar			
		4.0	8.0	12.0	16.0

R 717 (NH₃)

PMFL 80-1	+10	104	140	161	
	0	107	142	165	176
	-10	110	143	166	178
	-20	111	143	166	179
	-30	111	143	165	179
	-40	111	142	162	177
-50	109	140	160	175	
PMFL 80-2 PMFH 80-2	+10	167	224	257	
	0	172	227	264	281
	-10	176	228	265	284
	-20	177	238	264	285
	-30	177	227	262	284
	-40	175	225	258	281
-50	173	222	253	277	
PMFL 80-3 PMFH 80-3	+10	264	353	404	
	0	271	356	414	440
	-10	276	357	416	444
	-20	278	356	413	445
	-30	276	353	407	443
	-40	272	349	400	438
-50	267	343	393	431	
PMFL 80-4 PMFH 80-4	+10	427	571	651	
	0	438	573	664	704
	-10	444	572	665	709
	-20	445	568	657	709
	-30	439	561	647	704
	-40	429	552	635	696
-50	420	543	624	685	
PMFL 80-5 PMFH 80-5	+10	667	887	1010	
	0	679	883	1020	1080
	-10	685	874	1020	1080
	-20	680	864	1000	1080
	-30	666	852	984	1070
	-40	649	837	966	1060
-50	632	823	948	1040	
PMFL 80-6 PMFH 80-6	+10	1130	1490	1670	
	0	1130	1460	1690	1780
	-10	1130	1430	1670	1780
	-20	1110	1410	1640	1770
	-30	1080	1380	1610	1760
	-40	1050	1360	1570	1730
-50	1020	1340	1540	1710	
PMFL 80-7 PMFH 80-7	+10	1690	2220	2480	
	0	1670	2150	2500	2610
	-10	1660	2090	2470	2610
	-20	1630	2050	2410	2610
	-30	1580	2010	2350	2590
	-40	1530	1970	2300	2550
-50	1490	1940	2250	2510	
PMFL 125 PMFH 125	+10	2770	3650	4100	
	0	2770	3570	4140	4350
	-10	2770	3500	4090	4350
	-20	2720	3430	4010	4340
	-30	2650	3370	3920	4300
	-40	2570	3320	3840	4240
-50	2490	3260	3770	4180	
PMFL 200 PMFH 200	+10	4410	5810	6530	
	0	4420	5680	6590	6920
	-10	4400	5550	6510	6920
	-20	4330	5450	6370	6900
	-30	4210	5360	6240	6830
	-40	4080	5260	6110	6740
-50	3960	5170	5990	6640	
PMFL 300 PMFH 300	+10	6690	8810	9880	
	0	6690	8600	9980	10500
	-10	6660	8400	9850	10500
	-20	6550	8240	9650	10400
	-30	6360	8100	9430	10300
	-40	6170	7960	9240	10200
-50	5990	7820	9050	10000	
PMFH 500	+10	10700	14100	15800	
	0	10700	13700	15900	16700
	-10	10600	13400	15700	16700
	-20	10400	13100	15400	16700
	-30	10100	12900	15000	16500
	-40	9830	12700	14700	16300
-50	9540	12400	14400	16000	

Modulating liquid level regulators, servo-controlled, type PMFL / PMFH and SV
Capacity in kW (continued)

Type	Evaporating temperature t_e °C	Rated capacity in kW at pressure drop across valve Δp bar			
		0.8	1.2	1.6	2.0

R 22

PMFL 80-1	+10	11	13	15	17
	0	12	14	16	18
	-10	12	15	17	18
	-20	12	15	17	19
	-30	13	15	17	19
	-40	13	16	18	19
-50	13	16	18	19	
PMFL 80-2	10	18	22	25	27
	0	19	23	26	29
	-10	20	24	27	30
	-20	20	24	28	30
	-30	21	25	28	31
	-40	21	25	28	31
-50	21	25	28	31	
PMFL 80-3	10	29	35	39	43
	0	30	36	41	46
	-10	31	37	43	47
	-20	32	39	44	48
	-30	33	39	44	48
	-40	34	40	45	49
-50	34	40	44	48	
PMFL 80-4	10	47	57	64	71
	0	49	59	67	74
	-10	51	61	70	77
	-20	52	63	71	78
	-30	54	64	72	78
	-40	54	64	72	78
-50	55	64	71	77	
PMFL 80-5	10	74	89	102	112
	0	78	94	107	117
	-10	80	96	110	121
	-20	83	99	112	122
	-30	84	99	112	122
	-40	84	99	110	120
-50	84	97	108	117	
PMFL 80-6	10	129	156	177	194
	0	135	162	184	202
	-10	140	167	188	206
	-20	142	168	189	205
	-30	143	167	186	202
	-40	141	163	181	196
-50	137	158	175	189	
PMFL 80-7	10	202	242	273	299
	0	211	251	283	308
	-10	216	256	286	311
	-20	218	255	283	307
	-30	215	249	275	298
	-40	209	240	265	286
-50	200	230	254	275	
PMFL 125	10	321	386	437	479
	0	336	402	455	498
	-10	346	412	464	507
	-20	352	415	464	505
	-30	352	410	455	494
	-40	346	399	442	478
-50	335	386	426	461	
PMFL 200	10	515	618	700	767
	0	538	645	728	796
	-10	555	660	742	810
	-20	563	663	740	805
	-30	561	653	725	786
	-40	550	635	702	760
-50	532	612	677	732	
PMFL 300	10	782	940	1060	1170
	0	819	980	1110	1210
	-10	843	1000	1130	1230
	-20	855	1010	1120	1220
	-30	851	990	1100	1190
	-40	833	961	1060	1150
-50	804	925	1020	1110	

Type	Evaporating temperature t_e °C	Rated capacity in kW at pressure drop across valve Δp bar			
		4.0	8.0	12.0	16.0

R 22

PMFL 80-1	+10	22	28	31	32
	0	23	29	32	33
	-10	24	30	32	34
	-20	25	30	32	34
	-30	25	30	32	33
	-40	25	30	32	32
-50	24	29	31	32	
PMFL 80-2 PMFH 80-2	10	36	46	51	52
	0	38	47	52	53
	-10	39	48	52	54
	-20	40	48	52	54
	-30	40	48	52	53
	-40	40	48	51	52
-50	39	47	49	51	
PMFL 80-3 PMFH 80-3	10	57	72	80	82
	0	60	74	82	84
	-10	62	76	82	85
	-20	63	76	82	85
	-30	63	76	81	83
	-40	62	75	79	81
-50	61	73	77	79	
PMFL 80-4 PMFH 80-4	10	94	118	130	133
	0	98	121	133	136
	-10	101	123	133	138
	-20	102	123	132	137
	-30	101	122	130	134
	-40	99	120	127	131
-50	97	117	124	127	
PMFL 80-5 PMFH 80-5	10	147	184	202	206
	0	153	188	205	211
	-10	157	190	205	212
	-20	157	189	203	210
	-30	156	187	199	206
	-40	152	184	195	200
-50	148	179	189	194	
PMFL 80-6 PMFH 80-6	10	251	310	341	345
	0	260	314	343	352
	-10	263	315	341	353
	-20	262	313	335	348
	-30	257	308	328	340
	-40	249	302	320	331
-50	241	294	312	321	
PMFL 80-7 PMFH 80-7	10	381	466	510	515
	0	390	467	510	524
	-10	393	465	504	523
	-20	389	461	495	516
	-30	378	454	483	503
	-40	366	444	471	489
-50	353	433	458	473	
PMFL 125 PMFH 125	10	620	763	837	847
	0	639	770	842	864
	-10	647	771	835	865
	-20	643	767	821	853
	-30	628	755	804	834
	-40	609	739	784	810
-50	589	720	762	785	
PMFL 200 PMFH 200	10	990	1220	1330	1350
	0	1020	1230	1340	1380
	-10	1030	1230	1330	1380
	-20	1020	1220	1310	1360
	-30	1000	1200	1280	1330
	-40	969	1170	1250	1290
-50	937	1150	1210	1250	
PMFL 300 PMFH 300	10	1500	1850	2020	2050
	0	1550	1860	2030	2080
	-10	1560	1860	2010	2090
	-20	1550	1850	1980	2060
	-30	1510	1820	1930	2010
	-40	1470	1780	1890	1950
-50	1420	1730	1830	1890	
PMFH 500	10	2410	2950	3240	3270
	0	2480	2970	3250	3330
	-10	2500	2970	3210	3330
	-20	2480	2950	3160	3290
	-30	2420	2900	3090	3210
	-40	2340	2840	3010	3120
-50	2260	2770	2930	3020	

Material specification

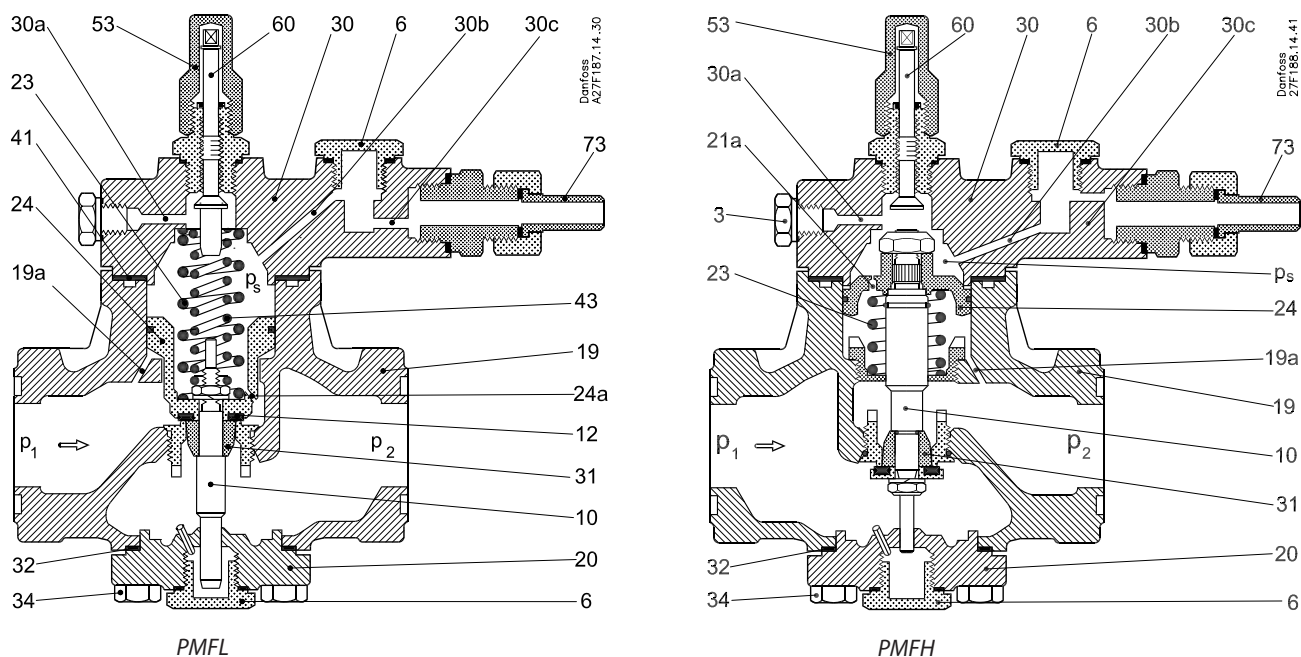

Material specification for PMFL/PMFH valves

No.	Part	Material	DIN/EN	ISO	ASTM
2	Gasket between body and flange	Non-metal Non-asbestos			
3	Bolts for flange	Stainless steel	A2-70	A2-70	Type 308
4	Flange PM 5 - 65	Steel	RSt. 37-2, 10025	Fe360 B, 630	Grade C, A 283
6	Plug	Steel	9SMn28 1651	Type 2 R683/9	1213 SAE J 403
10	Valve spindle	Steel	9SMn28 1651	Type 2 R683/9	1213 SAE J 403
12	Valve seat	Teflon [PTFE]			
19	Valve body	Low temperature cast iron (spherical)	EN-GJS-400-18-LT EN-1693		
20	Bottom cover	Low temperature cast iron (spherical)	EN-GJS-400-18-LT EN-1693		
23	Spring	Steel			
24	Servo piston	Cast iron	GG-25	Grade 250	Class 40B
30	Cover	Low temperature cast iron (spherical)	EN-GJS-400-18-LT EN-1693		
31	Trottle cone	Steel	9SMn28 1651	Type 2 R683/9	1213 SAE J 403
32	Gasket between body and bottom cover	Non-metal Non-asbestos			
34	Bolts for top and bottom cover	Stainless steel	A2-70	A2-70	Type 308
41	Gasket	Non-metal Non-asbestos			
43	Spring	Steel			
53	Spindle cap	Steel	9SMn28 1651	Type 2 R683/9	1213 SAE J 403
60	Setting / manual operating spindle	Steel	9SMn28 1651	Type 2 R683/9	1213 SAE J 403
73	Pilot connection	Steel	9SMn28 1651	Type 2 R683/9	1213 SAE J 403

Modulating liquid level regulators, servo-controlled, type PMFL / PMFH and SV

Ordering

Rated capacity in kW (1 kW = 0.284 TR)

Valve type	R 717	R 22	R 134a	R 404A	R 12	R 502
PMFL/H 80-1	139	27.8	22.1	33	17.4	30
PMFL/H 80-2	209	41.8	35.3	49.7	27.8	45.2
PMFL/H 80-3	348	70	53.1	82.7	41.8	75.2
PMFL/H 80-4	558	105	88.9	124	70	113
PMFL/H 80-5	835	174	133	207	105	188
PMFL/H 80-6	1395	278	221	330	174	300
PMFL/H 80-7	2080	435	353	569	278	470
PMFL/H 125	3480	700	552	831	435	755
PMFL/H 200	5580	1050	889	1243	700	1130
PMFL/H 300	8350	1740	1333	2068	1050	1880
PMFL/H 500	13900	2780	2210	3300	1740	3000

The rated capacity is given at evaporating temperature $t_e = +5^\circ\text{C}$, condensing temperature $t_c = +32^\circ\text{C}$ and liquid temperature $t_l = +28^\circ\text{C}$.

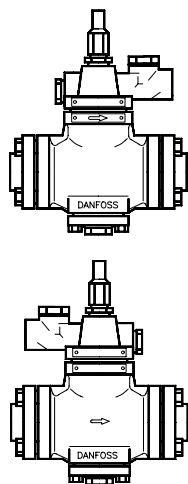

Main valve

Valve type	Code no.
	EN GJS 400-18-LT
PMFL 80-1	027F3054
PMFL 80-2	027F3055
PMFL 80-3	027F3056
PMFL 80-4	027F3057
PMFL 80-5	027F3058
PMFL 80-6	027F3059
PMFL 80-7	027F3060
PMFL 125	027F3061
PMFL 200	027F3062
PMFL 300	027F3063

Valve type	Code no.
	EN GJS 400-18-LT
PMFH 80-2	027F3065
PMFH 80-3	027F3066
PMFH 80-4	027F3067
PMFH 80-5	027F3068
PMFH 80-6	027F3069
PMFH 80-7	027F3070
PMFH 125	027F3071
PMFH 200	027F3072
PMFH 300	027F3073
PMFH 500	027F3074

The code nos. stated apply to main valves type PMFL or PMFH incl. flange gaskets, flange bolts, blanking plug and pilot connection with $\varnothing 6.5 / \varnothing 10$ mm weld nipple ($3/8$ in. flare connection can be supplied, code no. **027F0115**).

Spring set



DANFOSS
A27F205.10

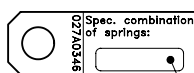

Weak/Strong

Special spring set for PMFL

Subcooling Δt_s K	Pressure drop Δp in PMFL		Pilot connection on SV 1-3 only	Pos.	Type PMFL	"WEAK"	"STRONG"
	4 → 15 bar	1.2 → 4 bar				Code no.	
	Spring set						
0-8	"STANDARD"	"WEAK"	P	23 + 43	80-1 → 80-7	027F0123	027F0118
8-40	"STRONG"		S		125	027F0124	027F0119
					200	027F0125	027F0120
					300	027F0126	027F0121

Special spring set for PMFH

Pressure drop in PMFH Δp bar	Type	"WEAK"
		Code no.
1 → 4	PMFH 80.1 → 7 PMFH 125 PMFH 200 PMFH 300	027F2190 027F2191 027F2192 027F2193

Modulating liquid level regulators, servo-controlled, type PMFL / PMFH and SV

Ordering (continued)

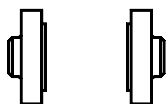

Flanges²⁾

Valve type	Flange type	Weld flanges		Solder flanges			
		in.	Code no. ¹⁾	in.	Code no. ¹⁾	mm	Code no. ¹⁾
PMFL 80 / PMFH 80	12	³ / ₄	027N1220	⁷ / ₈	027L1223	22	027L1222
		1	027N1225	¹ / ₈	027L1229	28	027L1228
		¹ / ₄	027N1230				
PMFL 125 / PMFH 125	23	¹ / ₄	027N2332	³ / ₈	027L2335	35	027L2335
		¹ / ₂	027N2340				
PMFL 200 / PMFH 200	24	¹ / ₂	027N2440	⁵ / ₈	027L2441	42	027L2442
		2	027N2450				
PMFL 300 / PMFH 300	25	2	027N2550	² / ₈	027L2554	54	027L2554
		² / ₂	027N2565				
PMFH 500	26	² / ₂	027N2665	² / ₈	027L2666	76	027L2676
		3	027N2680				

¹⁾ Code no. applies to one flange set consisting of one inlet and one outlet flange.

²⁾ Dimension sketch see spare part catalogue.

Stainless steel: flanges, bolts for flanges and top and bottom covers, see spare parts catalogue.

Pilot valves SV 1-3

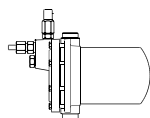

Type	Connection		Code no.	
Float pilot valve type SV	Balance tube liquid / vapour	Pilot line	SV 1: 027B2021	SV 3: 027B2023
	1 in. weld	Ø 6.5 / Ø 10 mm weld ¹⁾	027B2021CE ²⁾	027B2023CE ²⁾

¹⁾ ³/₈ in. flare connection can be supplied under code no. **027B2033**.

²⁾ Approved and CE-marked in accordance with Pressure Equipment Directive - 97/23/EC.

Pilot valves SV 4

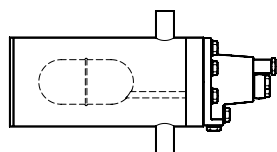

Valve type	Orifice diameter	Code no.	Code no. without housing ¹⁾
SV 4	Ø 3.0 mm	027B2024 ²⁾	027B2014 ²⁾

¹⁾ Flange for mounting without housing Code no. 027B2027.

²⁾ Approved and CE-marked in accordance with Pressure Equipment Directive - 97/23/EC.

The code nos. stated apply to liquid level regulators type SV 4, 5 and 6 with two 1" weld connections for balance tubes and two ½" weld joints for liquid and evaporator connections respectively.

Spare parts and accessories

Smaller orifices for the SV 4 are available as spare parts.

– Seal kit: **027B2070**

Special orifice code no. for SV 4

Orifice diameter	k _v	Code no. ¹⁾
Ø 1.0 mm	0,026	027B2080
Ø 1.5 mm	0,06	027B2081
Ø 2.0 mm	0,10	027B2082
Ø 2.5 mm	0,16	027B2083
Ø 2.8 mm	0,20	027B2084

¹⁾ The code no. includes orifice and all necessary gaskets

Pilot valve kits (EVM and coil)

Can be screwed on to the PMFL or PMFH instead of the blanking plug.



	a.c.: 027B1122xx where xx can be
Coils, 10 W a.c.	
110 V, 60 Hz	21
220 V, 50 Hz	31
220 V, 50/60 Hz	32
240 V, 50 Hz	33

Modulating liquid level regulators, servo-controlled, type PMFL / PMFH and SV

Ordering (continued)

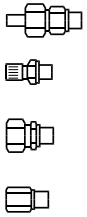

Optional accessories

Description		Code no.
Pressure gauge connection Ø 6.5 / Ø 10 mm weld / solder		027B2035
Pressure gauge connection 1/4 in. flare (self-closing) (Must not be used in ammonia plant)		027B2041
Pressure gauge connection Cutting ring connection	6 mm 10 mm	027B2063 027B2064
Pressure gauge connection	1/4 NPT	027B2062
Damping cylinder for PMFH 80 → 500		027F2195

Function indicator

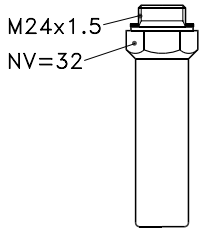

Description	Code no.
Function indicator Can be fitted in place of the main valve bottom plug. When the protective cap of the indicator is removed, the degree of opening of the PMFL-regulator can be observed in relation to the degree of opening of the SV pilot valve. Note: The function indicator must be considered as a very important tool for the accurate adjustment of the spring pressure.	027F0085
Manual operating unit for PMFL. Can be fitted in place of the regulator bottom plug	027F0128
3/8 in. flare pilot connection for PMFL and PMFH	027F0115
3/8 in. flare pilot connection for SV	027B2033

Dimensions and weights

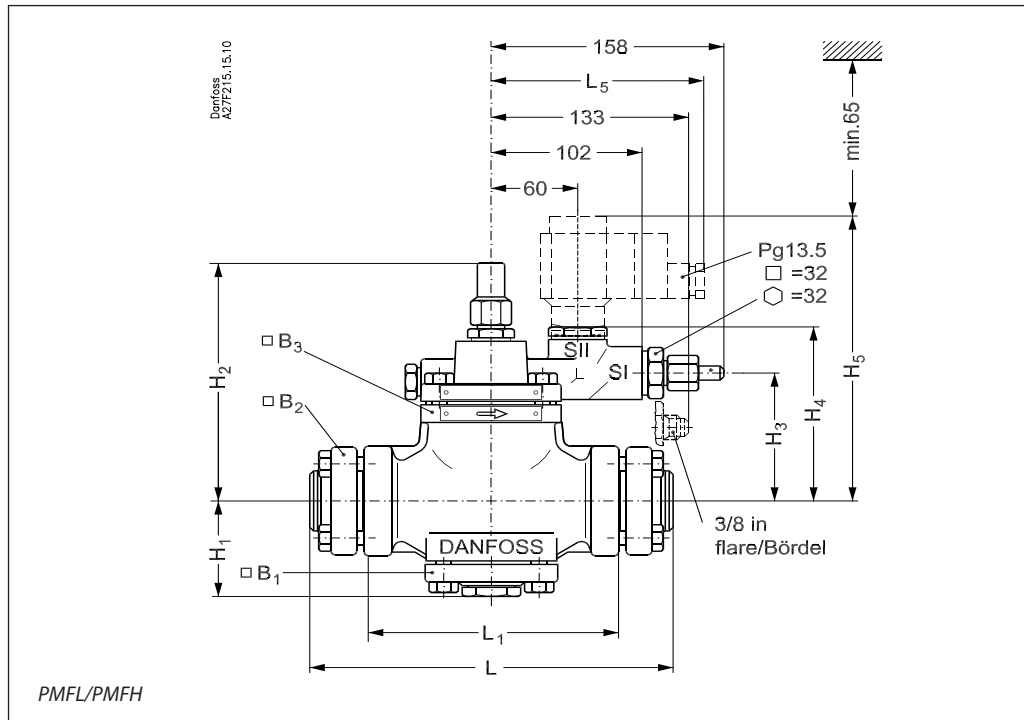

Type		H ₁ mm	H ₂ mm	H ₃ mm	H ₄ mm	H ₅ mm	L mm	L ₁ mm	L ₅ max.		B ₁ mm	B ₂ mm	B ₃ mm	Weight excl. solenoid valve kg
									10 W mm	20 W mm				
PMFL PMFH	80	66	162	79	113	176	177	106	130	140	75		87	7.0
	125	72	178	96	128	193	240	170	130	140	84	82	94	11.3
	200	79	187	105	138	202	254	170	130	140	94	89	102	14.2
	300	95	205	123	155	220	288	200	130	140	104	106	113	19.8
PMFH	500	109	227	146	176	242	342	250	130	140	127	113	135	28.3

www.danfoss.com/ir

Danfoss can accept no responsibility for possible errors in catalogues, brochures and other printed material. Danfoss reserves the right to alter its products without notice. This also applies to products already on order provided that such alterations can be made without consequential changes being necessary in specifications already agreed. All trademarks in this material are property of the respective companies. Danfoss and the Danfoss logotype are trademarks of Danfoss A/S. All rights reserved.