

ELECTRIC VALVE ACTUATOR TYPE CAR

FOR 3-WAY VALVES TYPE L3FM-T, M3FM-T, G3FM-T

4.11.08-E

GB-1



TECHNICAL DATA

Casing:	Watertight IP67, Nema 4 and 6
Ambient temp.:	-30°C to +70°C, 150°C/1 hr.
Power Supply:	120/230 VAC, 1-Phase (50Hz/60Hz) 380/400/440 VAC, 3-Phase (50Hz/60Hz) 24 VDC (CAR 015-028)
Torque switches:	Open/Close
Limit switches:	Open/Close, additional limit switches on request
Stall protection:	Built-in Thermal Protection Cut-off at 150°C ± 5°C / Reset at 97°C ± 15°C
Travel angle:	90° ± 5°
Indicator:	Continuous Position Indicator
Manual override:	AUTO Declutching Mechanism
Worm gear:	Permanently lubricated and Self-locking
Mechanical stops:	External Adjustable Limit Stops
Space heater:	20 W (115/230 VAC, 24 VDC) Anti-Condensation 2 x R 3/4"
Cabeling:	2 x R 3/4"
Lubrication:	Grease NLGI Grade 2 (EP-Type)
Materials:	Steel, Aluminium Alloy, Al Bronze
External coating:	Anodizing and Dry Powder Epoxy
Duty Cycle:	On-Off: 52 50% Modulating: 54 75%

RECOMMENDED ACTUATOR TYPES FOR G3FM-T VALVES

Valve size	Actuator type		
	DP 5 bar	DP 10 bar	DP 16 Bar
DN 150	CAR 019	CAR 028	CAR 028
DN 200			
DN 250	CAR 028	CAR 060	CAR 060
DN 300	CAR 060		CAR 100
DN 350		CAR 100	
DN 400	CAR 100		
DN 450			
DN 500	CAR 200	CAR 200	
DN 600			

APPLICATION

Electric valve actuator type CAR is specially designed to meet the demands of the powerful low frequency vibration environments in marine installations.

The main applications are cooling of freshwater, sea water and lubricating oil systems for main and auxiliary engines. The actuator is used for Clorius 3-way valves type L3FM-T, M3FM-T and G3FM-T.

MOUNTING

For mounting and starting up, the instructions delivered with the actuator must be followed carefully.

SERVICE

No special service is needed. It is recommended to check and grease the actuator at every docking or every three years.

SPECIFICATIONS

Type	Max. torque Nm	Operating time sek/90° (50/60 Hz)	Weight kg	No. of handle turns	Current draw max. A (1-phase 120V)	Current draw max. A (1-phase 230V)	Current draw max. A (3-ph 400V)	Current draw max. A (24 VDC)
CAR 019	186	17/20	13	10	1,5	0,7	0,28	-
CAR 028	274	24/20	17	12.5	2	0.7	0.3	7
CAR 060	588	29/24	22	14.5	3.1	1.18	0.5	-
CAR 100	981	29/24	25	14.5	4.5	2	0.87	-
CAR 150	1471	87/72	68	43.5	3.1	1.18	0.5	-
CAR 200	1962	87/72	70	43.5	4.5	1.8	0.8	-

ELECTRIC VALVE ACTUATOR TYPE CAR

FOR 3-WAY VALVES TYPE L3FM-T, M3FM-T, G3FM-T

4.11.08-E

GB-2

DIMENSION SKETCH

CAR 028 - 100

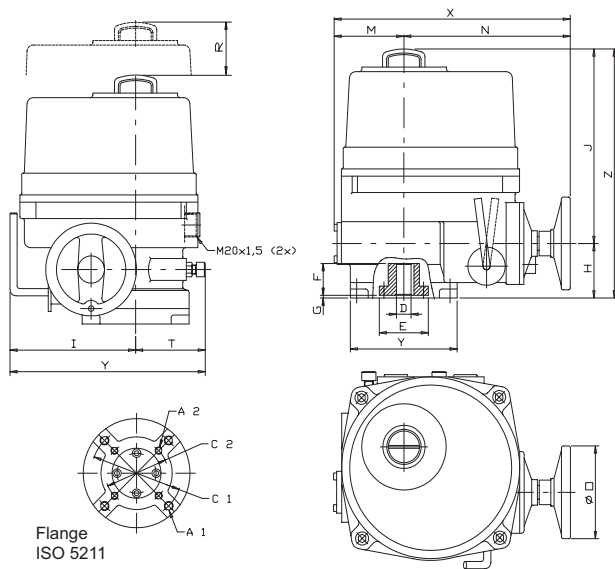

CAR 150 - 200

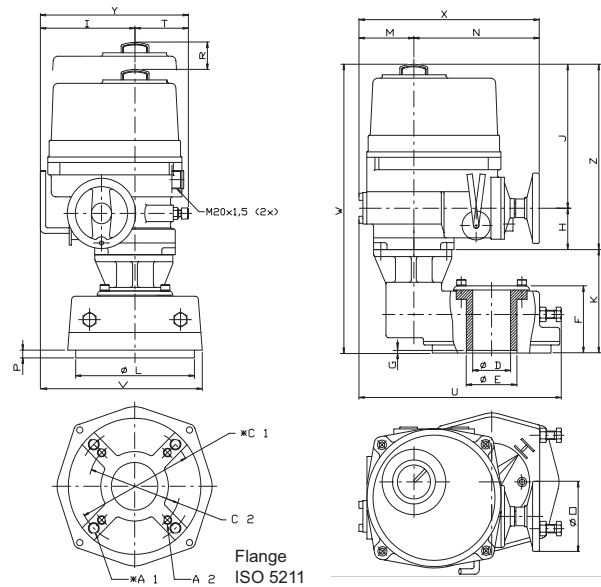

Type	CAR 019	CAR 028	CAR 060	CAR 100	CAR 150	CAR 200
Flange	F07, F10	F12, F10		F14, F12		F16, F14*
C1	102	125		140		165
C2	70	102		125		140*
A1	M10	M12		M16		M14*/M15*
A2	M8	M10		M12		M20
B	15	18		22		30
D(Max**)	22	32		42		75
E	57	75		85		100
F	43	52		59		126
G	2	2		2		7
H	60	70		78		78
I	139	159		191		191
J	213	250		283		283
K	-	-		-		195
L	120	145		175		266
M	77	83		99		99
N	184	202		226		226
O	102	125		170		170
P	-	-		-		16
R	108	130		178		178
T	85	99		116		116
U	-	-		-		388
V	-	-		-		318
W	-	-		-		556
X	261	285		325		325
Y	224	258		307		307
Z	273	320		361		361

* For optional alternative flanges
 ** Maximum dimension including keyway

ACCESSORIES

CAR PROPORTIONAL CONTROL UNIT PCU PB90

CAR 028-200

Command signal input	4-20 mA, nominal input impedance 150 Ohm, jumpers I1 and I2 0-10 V, nominal input impedance 260k Ohm, jumper V1
Analogue feedback signal	4-20 mA, self powered, can drive up to 300 Ohm
Fuse	3,15 AT 5x20 mm, mounted on the PB90 card
Resolution	Approx. 0,3%
Conversion	12 bit maximum. Normal range (4-20 mA) = 1/3200.

Position board. Characteristic of feedback element and actuator system response affect the true performance.

CLS : CLOSE LIMIT SWITCH (250VAC 15A)
 OLS : OPEN LIMIT SWITCH (250VAC 15A)
 CTS : CLOSE TORQUE SWITCH (250VAC 15A)
 OTS : OPEN TORQUE SWITCH (250VAC 15A)
 TP : THERMAL PROTECTOR (250VAC 15A)

	CLOSE	OPEN
CLS 1-2	_____	_____
CLS 1-3	_____	_____
OLS 1-2	_____	_____
OLS 1-3	_____	_____
CTS 1-3	* CLOSING TORQUE SWITCH INTERRUPTS CONTROL IF MECHANICAL OVERLOAD OCCURS DURING CLOSING CYCLE	
OTS 1-3	* OPENING TORQUE SWITCH INTERRUPTS CONTROL IF MECHANICAL OVERLOAD OCCURS DURING OPENING CYCLE	

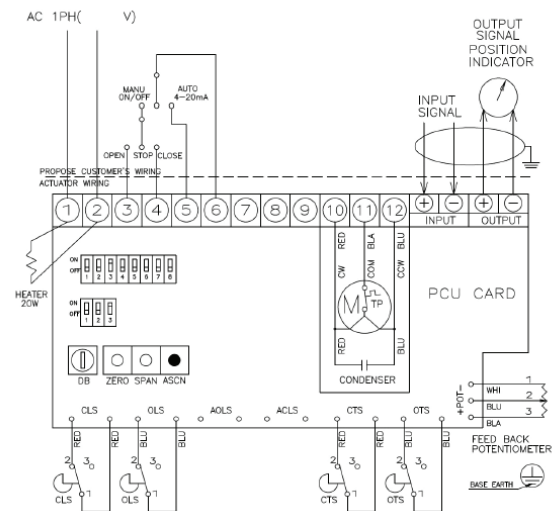

CAR 028-200

CAR CURRENT POSITION TRANSMITTER CPT

- For continuous, analogue feed back signal 4-20 mA
- R/I Transmitter
- The electronic components are protected against dirt and similar

CLS : CLOSE LIMIT SWITCH (250VAC 6A)
 OLS : OPEN LIMIT SWITCH (250VAC 6A)
 CTS : CLOSE TORQUE SWITCH (250VAC 6A)
 OTS : OPEN TORQUE SWITCH (250VAC 6A)
 TP : THERMAL PROTECTOR (250VAC 15A)

	CLOSE	OPEN
CLS 1-2	_____	_____
CLS 1-3	_____	_____
OLS 1-2	_____	_____
OLS 1-3	_____	_____
CTS 1-3	* CLOSING TORQUE SWITCH INTERRUPTS CONTROL IF MECHANICAL OVERLOAD OCCURS DURING CLOSING CYCLE	
OTS 1-3	* OPENING TORQUE SWITCH INTERRUPTS CONTROL IF MECHANICAL OVERLOAD OCCURS DURING OPENING CYCLE	

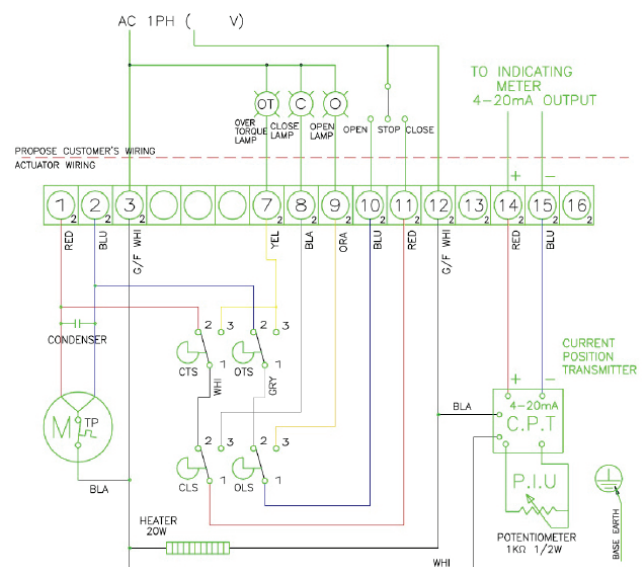

Subject to changes without notice.



ACCESSORIES

CAR 028-200

CAR POTENTIOMETER PIU

- For CAR 006 - CAR 250
- For continuous position feedback from 0° to 90°
- The whole unit is built into the actuator
- Potentiometer 1k Ohm, senses the actuator position during the whole turning movement
- Mounting details included
- Resistance 1k Ohm
- Resistance tolerance ±20%
- Linearity ±1%
- Max load 1W at +70 °C

CLS : CLOSE LIMIT SWITCH (250VAC 6A)
 OLS : OPEN LIMIT SWITCH (250VAC 6A)
 CTS : CLOSE TORQUE SWITCH (250VAC 6A)
 OTS : OPEN TORQUE SWITCH (250VAC 6A)
 TP : THERMAL PROTECTOR (250VAC 15A)

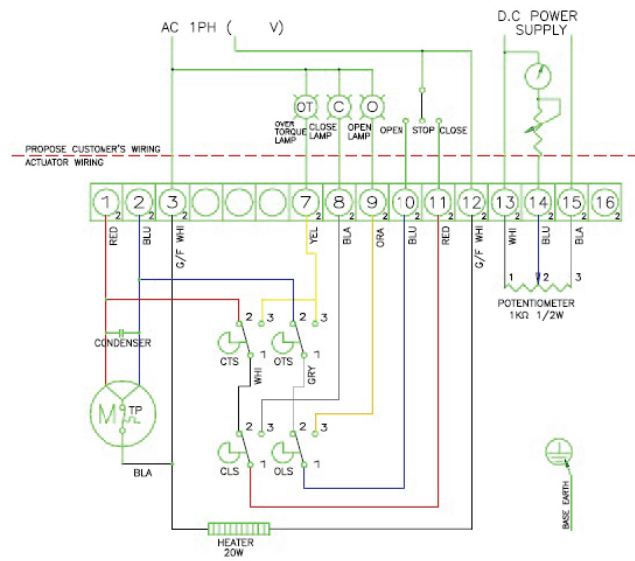
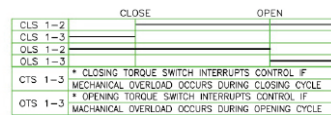

Subject to changes without notice.