

# Thermostats of stainless steel types V4.03 and V4.05

3.4.05-E

GB-1

## Characteristics

- Self-acting
- P-controller
- Completely sealed
- Excess temperature protection
- All parts made of stainless steel
- Non-magnetic

## Application

The thermostat is particularly suitable for installation in demanding environments such as tank installations, outdoor plants and where it must be non-magnetic, e.g. in submarines.

## Function

The adjusting cylinder of the thermostat is set at the temperature in °C for the required heated medium. The temperature is regulated by the thermostatically controlled valve reducing or increasing the flow of the heating medium. Together with the adjusting cylinder, the liquid-filled sensor and capillary tube constitute a closed system.

If the temperature of the medium to be heated is above the required level, the sensor liquid expands, causing the spindle of the thermostat to act upon the valve, thereby reducing the flow of the heating medium.

If the temperature is below the required level, the temperature of the liquid in the sensor decreases and the volume is reduced, thereby the valve spring opens the valve causing an increasing flow of the heating medium.

## Construction

The parts of the thermostat are made of stainless steel. The thermostat consists of a liquid-filled sensor, a capillary tube, and an adjusting cylinder.

The adjusting cylinder has O-ring sealings and is sealed with silicone glue at the top for hermetical closure. The thermostat is available with settings between -30°C and +280°C.

At flow temperatures above 170°C, a cooling unit must be installed between the valve and the thermostat. Please see datasheet no. 8.5.00.

## Neutral Zone

The neutral zone of the thermostat, which is less than 2°C, is the temperature difference which can occur at the sensor without the thermostat spindle being actuated.

## Sensor types

Rod or spiral sensors of stainless steel with pipe thread.

Sensors are also available with a pack-box on the capillary tube for applications where the sensor is to be lowered into a tank etc.

## Sensor liquid

Glycerine at a scale range between -30°C and 160°C.

Paraffin at a scale range between 140°C and 280°C.

## Capillary tube

The capillary tube is made of stainless steel and is available in lengths from 3 m up to 21 m.

## Valves

The thermostat may be used for valves up to DN 150 mm for heating and cooling plants.

See data sheet "Quick choice of temperature controller" no. 9.0.00 and data sheet for the particular valve.



## Technical data

Max. closing force	500 N
Standard settings:	
- Type V4.03	0-160 °C
- Type V4.05	0-120, 40-160 °C
Reinforcement (mm/°C):	
(Glycerine)	Type V4.03: 0.3 Type V4.05: 0.5
(Paraffin)	Type V4.03: 0.33 Type V4.05: 0.7
For valves with lifting height up to	21 mm
Sensor material	W. No. 1.4436
Time constant for rod sensor:	
- Type V4.03:	90 sec.
- Type V4.05:	100 sec.
Time constant for spiral sensor, sec.	20
Neutral zone	< 2°C
Excess temperature protection	40°C

Subject to change without notice.

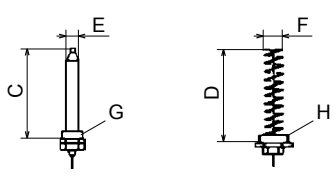
Sensors with pipe thread	Type V4.03	Type V4.05
	C 190 mm D 170 mm E 22 mm F 49 mm G* 1" H* 2"	380 mm 250 mm 22 mm 49 mm 1" 2"
Weight including G connection	2.4 kg	2.6 kg
Weight including H connection	2.9 kg	3.1 kg

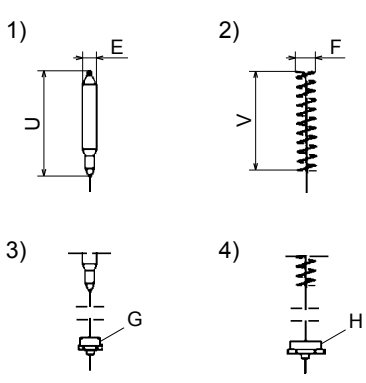
Sensors without connection Available with capillary packbox	Type V4.03	Type V4.05	
	E 22 mm F 49 mm U 230 mm V 220 mm G* 1" H* 2"	22 mm 49 mm 410 mm 310 mm 1" 2"	
Weight	1)	2.2 kg	2.3 kg
	2)	2.2 kg	2.4 kg
	3)	2.4 kg	2.6 kg
	4)	2.9 kg	3.1 kg

\* The measurements G and H are pipe threads according to ISO R7/1.

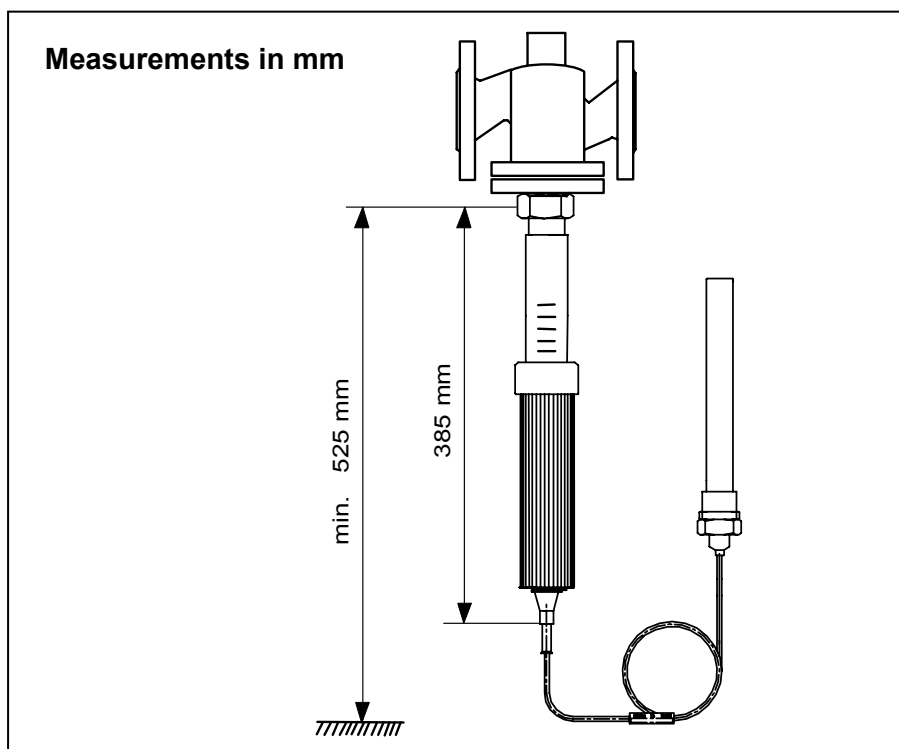

Subject to change without notice.