

Miniature resistance thermometer Explosion-protected version Model TR34, thread-mounted

WIKA data sheet TE 60.34



Applications

- Machine building, plant and vessel construction
- Propulsion technology, hydraulics

Special features

- Intrinsically safe Ex i version, very compact design, high vibration resistance and fast response time
- With direct sensor output (Pt100, Pt1000 in 2-, 3- or 4-wire connection) or integrated transmitter with 4 ... 20 mA output signal
- Integrated transmitter is individually parameterisable with free-of-charge WIKAsoft-TT PC configuration software
- Sensor element with accuracy class A in accordance with IEC 60751
- EMC conformity in accordance with NAMUR NE21

Description

Resistance thermometers of this series are used as universal thermometers for the measurement of liquid and gaseous media in the range -50 ... +250 °C (-58 ... +482 °F). The instruments are intrinsically safe and suitable for use in hazardous areas.

They can be used for pressures up to 140 bar with 3 mm sensor diameters and up to 270 bar with 6 mm sensor diameters, depending on the instrument version. All electrical components are protected against humidity (IP 67 or IP 69K) and designed to withstand vibration (20 g, depending on instrument version).

The resistance thermometer is available with direct sensor output or integrated transmitter, which can be configured individually via the PC configuration software WIKAsoft-TT. Measuring range, damping, fault signal per NAMUR NE43 and TAG no. can be adjusted.

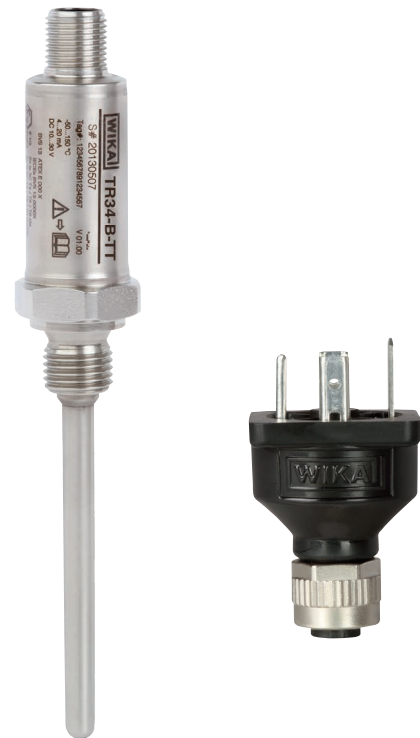

Fig. left: Resistance thermometer, model TR34
Fig. right: M12 x 1 adapter to DIN EN 175301-803 angular connector

Insertion length, process connection, sensor and connection method can each be selected for the respective application within the order information. The model TR34 resistance thermometer consists of a thermowell with a fixed process connection and is screwed directly into the process. The electrical connection is made via an M12 x 1 circular connector. An adapter for electrical connection with angular connector per DIN EN 175301-803 is optionally available (industrial property rights registered under No. 001370985).

Sensor

The sensor is located in the tip of the thermometer.

The resistance thermometers of the series TR34 are designed for direct installation into the process. Using it in an additional thermowell is not advisable.

Sensor diameter in mm	Process connection						
	G ¼ B	G ¾ B	G ½ B	¼ NPT	½ NPT	M12 x 1.5	M20 x 1.5
3	x	x	x	x	x	x	x
6	x	x	x	x	x	x	x

Sensor tube length										
Sensor diameter in mm	Insertion length U ₁ in mm									
	50	75	100	120	150	200	250	300	350	400
3	x	-	-	-	-	-	-	-	-	-
6	x	x	x	x	x	x	x	x	x	x

Further sensor tube lengths on request.

Specifications

Thermometer with transmitter and 4 ... 20 mA output signal (model TR34-x-TT)	
Temperature range	without neck tube -50 ... +150 °C (-58 ... +302 °F) with neck tube -50 ... +250 °C (-58 ... +482 °F) ¹⁾
Measuring element	Pt1000
Connection method	2-wire
Tolerance value of the measuring element per IEC 60751	Class A ²⁾
Measuring deviation of the transmitter per IEC 60770	±0.25 K
Total measuring deviation in accordance with IEC 60770	Measuring deviation of the measuring element + the transmitter
Measuring span	minimum 20 K, maximum 300 K
Basic configuration	Measuring range 0 ... 150 °C (32 ... 302 °F), other measuring ranges are adjustable
Analogue output	4 ... 20 mA, 2-wire
Linearisation	Linear to temperature per IEC 60751
Linearisation error	±0.1 % ³⁾
Switch-on delay, electrical (time before the first measured value)	max. 4 s
Warming-up period	After approx. 4 minutes, the instrument will function to the specifications (accuracy) given in the data sheet.
Current signal for fault signal	configurable in accordance with NAMUR NE43 downscale ≤ 3.6 mA upscale ≥ 21.0 mA
Sensor short-circuit	not configurable, in accordance with NAMUR NE43 downscale ≤ 3.6 mA
Sensor current	< 0.3 mA (self-heating can be ignored)
Load R _A	$R_A \leq (U_B - 10 V) / 23 \text{ mA}$ with R _A in Ω and U _B in V
Effect of load	±0.05 % / 100 Ω
Power supply U _B	DC 10 ... 30 V
Max. permissible residual ripple	10 % generated by U _B < 3 % ripple of the output current
Power supply input	protected against reverse polarity
Power supply effect (Depending on the power supply U _B)	±0.025 % / V
Influence of the ambient temperature	0.1 % of span / 10 K T _a
Electromagnetic compatibility (EMC) ⁵⁾	2004/108/EC, EN 61326 emission (group 1, class B) and interference immunity (industrial application) ⁴⁾ , configuration at 20 % of the full measuring range
Temperature units	configurable °C, °F, K
Info data	TAG No., description and user message can be stored in transmitter
Configuration and calibration data	permanently stored
Electrical connection	M12 x 1, 4-pin circular connector
Explosion protection	Intrinsically safe to Ex i (ATEX) gas/dust, per directive 94/9/EC (for further information see "Further specifications for explosion-protected version")

Readings in % refer to the measuring span

- 1) The temperature transmitter should therefore be protected from temperatures over 85 °C (185 °F).
- 2) Class accuracy A only valid in the temperature range -30 ... +150 °C (-22 ... +302 °F) or -30 ... +250 °C (-22 ... +482 °F), otherwise class B
- 3) ±0.2 % for measuring ranges with a lower limit less than 0 °C (32 °F)
- 4) Use resistance thermometers with shielded cable, and ground the shield on at least one end of the lead, if the lines are longer than 30 m or leave the building. The instrument must be operated grounded.
- 5) During transient interferences (e.g. burst, surge, ESD) take into account an increased measuring deviation of up to 2 %.

Thermometer with direct sensor output with Pt100 (model TR34-x-Px) and Pt1000 (model TR34-x-Sx)

Temperature range	without neck tube -50 ... +150 °C (-58 ... +302 °F) with neck tube -50 ... +250 °C (-58 ... +482 °F)
Temperature at the connector	max. 85 °C (185 °F)
Measuring element	■ Pt100 (measuring current: 0.1 ... 1.0 mA) ■ Pt1000 (measuring current: 0.1 ... 0.3 mA)
Connection method	■ 2-wire The lead resistance is recorded as an error in the measurement. ■ 3-wire With a cable length of 30 m or longer, measuring deviations can occur. ■ 4-wire The lead resistance can be ignored.
Tolerance value of the measuring element per IEC 60751	■ Class A ⁶⁾ ■ Class B at 2-wire
Electrical connection	M12 x 1, 4-pin circular connector
Explosion protection	Intrinsically safe to Ex i (ATEX) gas/dust, per directive 94/9/EC (for further information see "Further specifications for explosion-protected version")

For detailed specifications for Pt sensors, see Technical information IN 00.17 at www.wika.com.

Case

Material	Stainless steel
Ingress protection	
■ Case with connected connector	IP 67 and IP 69 per IEC 60529/EN 60529, IP 69K per ISO 20653 The stated ingress protection only applies when plugged in using mating connectors that have the appropriate ingress protection.
■ Coupler connector, not connected	IP 67 per IEC 60529/EN 60529
Weight in kg	approx. 0.2 ... 0.7 (depending on version)
Dimensions	see "Dimensions in mm"

Ambient conditions

Ambient temperature range	
■ Model TR34-x-TT	-40 ... +85 °C (-40 ... +185 °F)
■ Models TR34-x-Px, TR34-x-Sx	-50 ... +85 °C (-58 ... +185 °F)
Storage temperature range	-40 ... +85 °C (-40 ... +185 °F)
Climate class per IEC 60654-1	
■ Model TR34-x-TT	Cx (-40 ... +85 °C or -40 ... +185 °F, 5 ... 95 % r. h.)
■ Models TR34-x-Px, TR34-x-Sx	Cx (-50 ... +85 °C or -58 ... +185 °F, 5 ... 95 % r. h.)
Maximum permissible humidity per IEC 60068-2-30 var. 2	r. h. 100 %, condensation allowed
Maximum operating pressure ^{7) 8)}	140 bar with 3 mm sensor diameter 270 bar with 6 mm sensor diameter
Vibration per IEC 60751	10 ... 2,000 Hz, 20 g ⁷⁾
Shock	IEC 60068-2-27
Salt fog	IEC 60068-2-11

6) Class accuracy A only valid in the temperature range -30 ... +150 °C (-22 ... +302 °F) or -30 ... +250 °C (-22 ... +482 °F), otherwise class B

7) Dependent on the instrument version

8) Reduced operating pressure when using a compression fitting: Stainless steel: max. 100 bar
PTFE: max. 8 bar

Further specifications for explosion-protected version

■ Thermometer with transmitter and 4 ... 20 mA output signal (model TR34-x-TT)

Marking:

Hazardous gas atmosphere	Temperature class	Ambient temperature range (T_a)	Maximum surface temperature (T_{max}) at the sensor or thermowell tip
II 1 G Ex ia IIC T1 - T6 Ga	T6	-40 ... +45 °C	T_M (medium temperature) + self-heating (15 K)
II 1/2 G Ex ia IIC T1 - T6 Ga/Gb	T5	-40 ... +60 °C	Pay attention to the specific conditions for safe use.
II 2 G Ex ia IIC T1 - T6 Gb	T4	-40 ... +85 °C	
	T3	-40 ... +85 °C	
	T2	-40 ... +85 °C	
	T1	-40 ... +85 °C	

Hazardous dust atmosphere	Power P_i	Ambient temperature range (T_a)	Maximum surface temperature (T_{max}) at the sensor or thermowell tip
II 1 D Ex ia IIIC T135°C Da	750 mW	-40 ... +40 °C	T_M (medium temperature) + self-heating (15 K)
II 1/2 D Ex ia IIIC T135°C Da/Db	650 mW	-40 ... +70 °C	Pay attention to the specific conditions for safe use.
II 2 D Ex ia IIIC T135°C Db	550 mW	-40 ... +85 °C	

Safety-related maximum values for the current loop (+ and - connections):

Parameters	Hazardous gas atmosphere	Hazardous dust atmosphere
Terminals	+ / -	+ / -
Voltage U_i	DC 30 V	DC 30 V
Current I_i	120 mA	120 mA
Power P_i	800 mW	750/650/550 mW
Effective internal capacitance C_i	29.7 nF	29.7 nF
Effective internal inductance L_i	negligible	negligible
Maximum self-heating at the sensor or thermowell tip	15 K	15 K

■ Thermometer with direct sensor output with Pt100 (model TR34-x-Px) and Pt1000 (model TR34-x-Sx)

Marking:

Marking	Temperature class	Ambient temperature range (T_a)	Maximum surface temperature (T_{max}) at the sensor or thermowell tip
II 1 G Ex ia IIC T1 - T6 Ga	T6	-50 ... +80 °C	T_M (medium temperature) + self-heating Pay attention to the specific conditions for safe use (17).
II 1/2 G Ex ia IIC T1 - T6 Ga/Gb	T5	-50 ... +85 °C	
	T4	-50 ... +85 °C	
	T3	-50 ... +85 °C	
	T2	-50 ... +85 °C	
II 2 G Ex ia IIC T1 - T6 Gb	T1	-50 ... +85 °C	

Marking	Power P_i	Ambient temperature range (T_a)	Maximum surface temperature (T_{max}) at the sensor or thermowell tip
II 1 D Ex ia IIIC T135°C Da	750 mW	-50 ... +40 °C	T_M (medium temperature) + self-heating
II 1/2 D Ex ia IIIC T135°C Da/Db	650 mW	-50 ... +70 °C	Pay attention to the specific conditions for safe use (17).
II 2 D Ex ia IIIC T135°C Db	550 mW	-50 ... +85 °C	

Safety-related maximum values for the current loop (connections in accordance with pin assignment 1 - 4):

Parameters	Gas applications	Dust applications
Terminals	1 - 4	1 - 4
Voltage U_i	DC 30 V	DC 30 V
Current I_i	550 mA	250 mA
Power P_i	1,500 mW	750/650/550 mW
Effective internal capacitance C_i	negligible	negligible
Effective internal inductance L_i	negligible	negligible
Maximum self-heating at the sensor or thermowell tip	$(R_{th}) = 335 \text{ K/W}$	$(R_{th}) = 335 \text{ K/W}$

Dimensions in mm

Process connection with parallel threads (or without process connection)

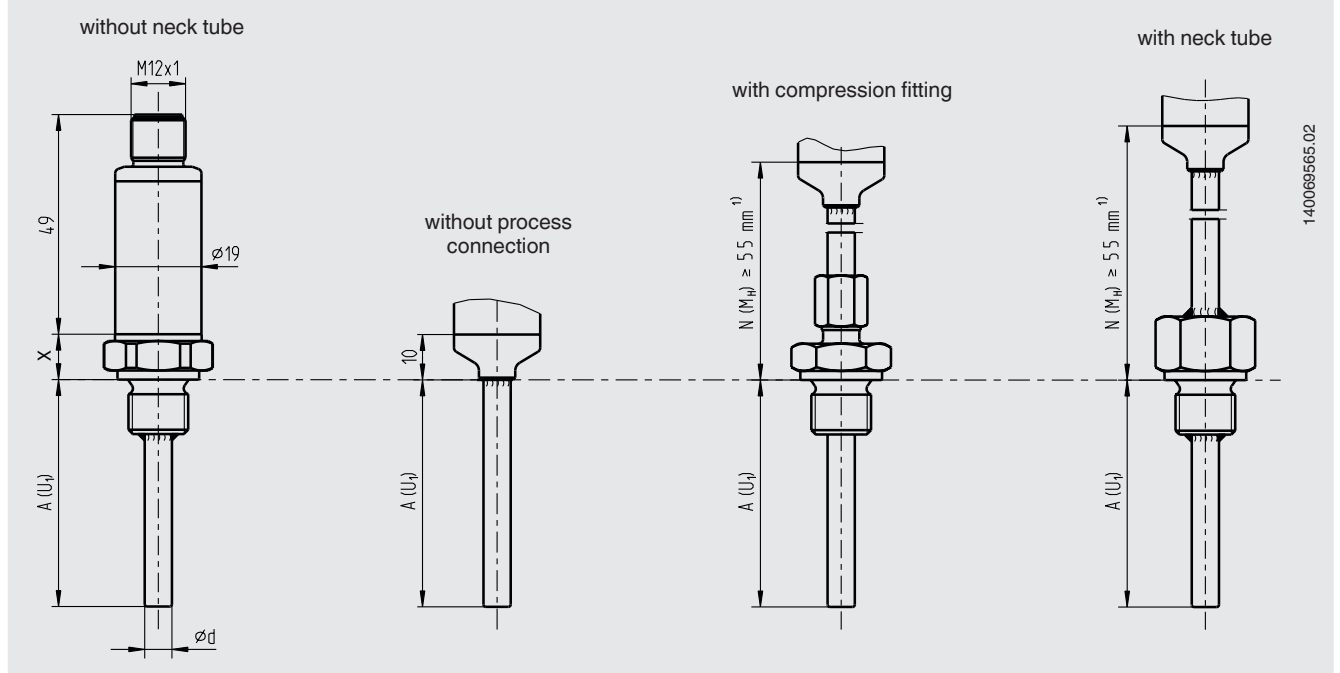

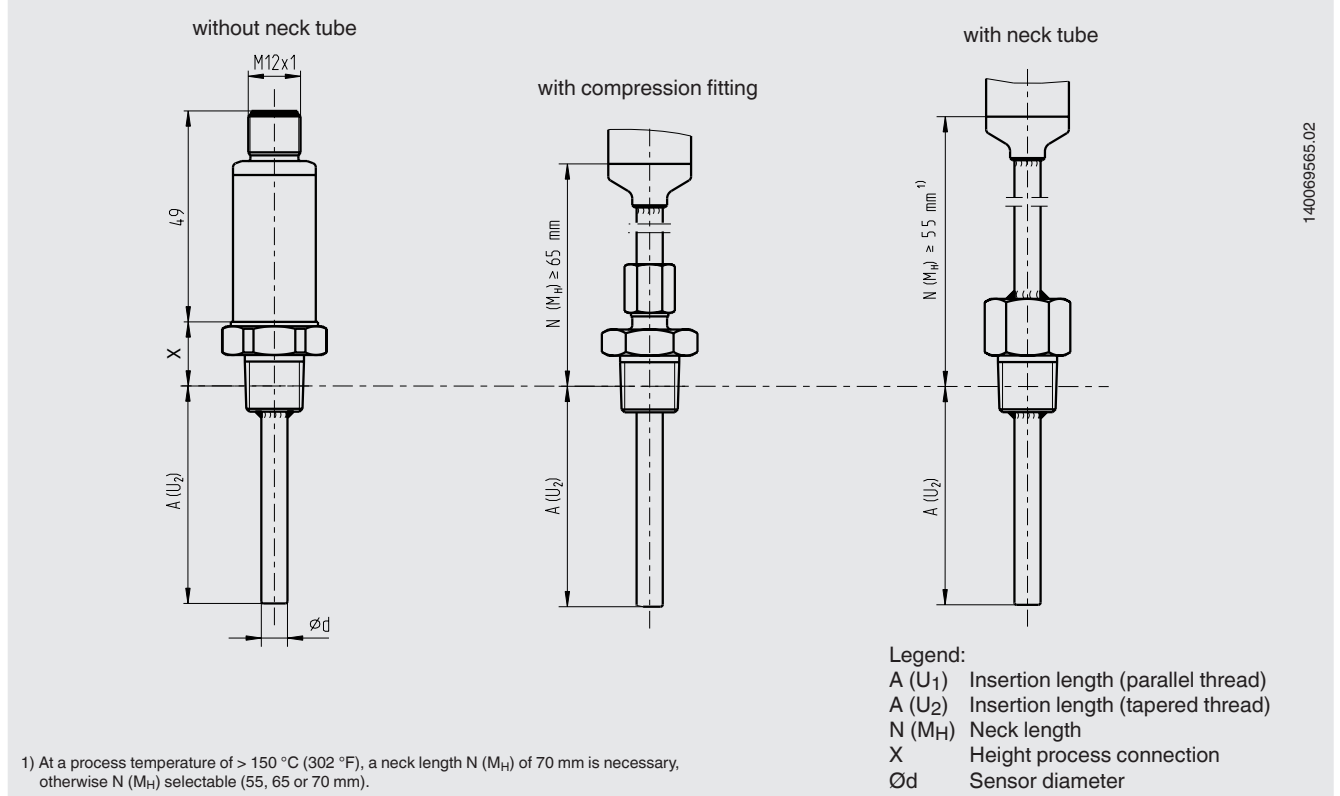

Process connection with tapered thread

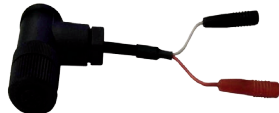
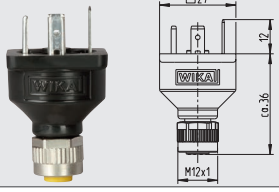
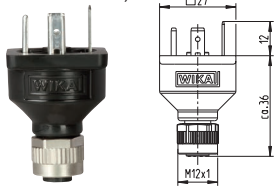

Thread	Height process connection X
G 1/2	11
G 3/8	11
G 1/4	10
1/4 NPT	15
1/2 NPT	19
M12	11
M20	11

Accessories

Model	Special features	Order no.
Programming unit Model PU-448 	<ul style="list-style-type: none"> ■ Easy to use ■ LED status/diagnostic displays ■ Compact design ■ No further voltage supply is needed for either the programming unit or for the transmitter 	11606304
Adapter cable M12 to PU-448 	Adapter cable for the connection of a model TR34 resistance thermometer to the model PU-448 programming unit	14003193
M12 x 1 transmitter adapter to angular connector DIN EN 175301-803 (yellow female connector element) 	Adapter for the connection of a resistance thermometer with a DIN EN 175301-803 form A angular connector with a 4 ... 20 mA output signal (data sheet AC 80.17) Case: PA Ambient temperature: -40 ... +115 °C Union nut: zinc diecast Contacts: copper-zinc alloy, tin-plated Dielectric strength: 500 V Ingress protection: IP 65	14069503
M12 x 1 Pt adapter to angular connector DIN EN 175301-803 (black female connector element) 	Adapter for the connection of the resistance thermometer with a DIN EN 175301-803 form A angular connector with direct resistance output signal (data sheet AC 80.17) Case: PA Ambient temperature: -40 ... +115 °C Union nut: zinc diecast Contacts: copper-zinc alloy, tin-plated Dielectric strength: 500 V Ingress protection: IP 65	14061115
Angular connector 	per DIN EN 175301-803 form A	11427567
Sealing for angular connector 	for use with angular connector DIN EN 175301-803-A EPDM, brown	11437902

Configuration software WIKAsoft-TT

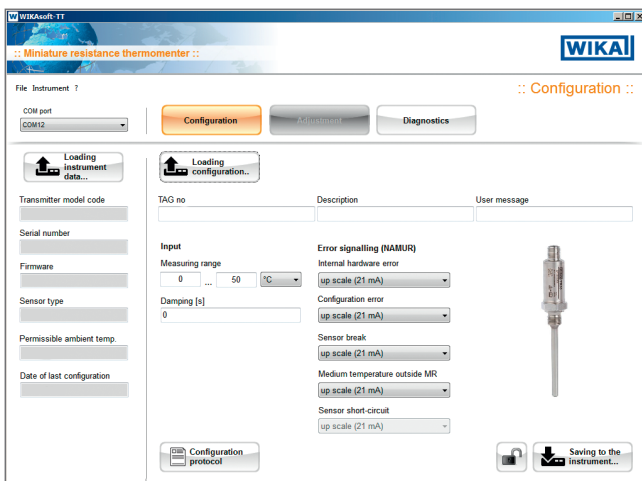

Configuration software (multilingual) as a download from www.wika.com

Connecting PU-448 programming unit

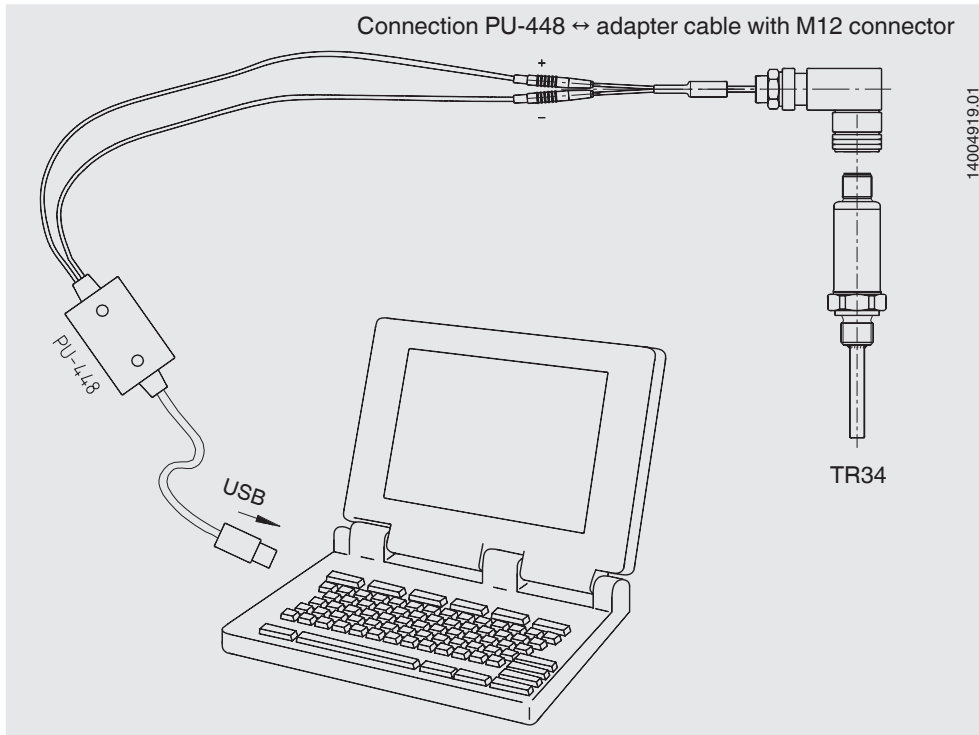

Electrical connection

Output signal 4 ... 20 mA
Circular connector M12 x 1, 4-pin

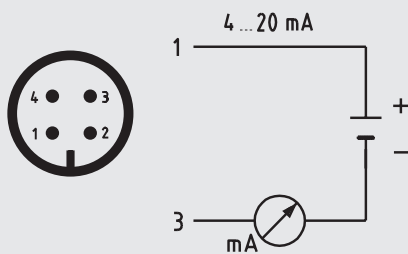

Pin	Signal	Description
1	L+	10 ... 30 V
2	VQ	not connected
3	L-	0 V
4	C	not connected

Output signal Pt100 or Pt1000 sensor
Circular connector M12 x 1, 4-pin

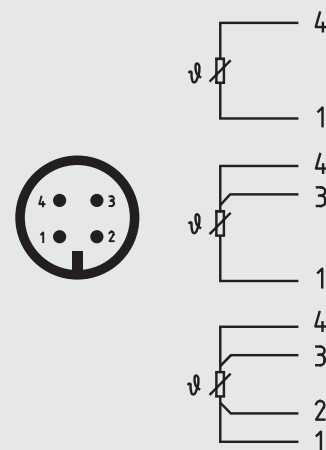

Load diagram

The permissible load depends on the loop supply voltage. For communication with the instrument with programming unit PU-448, a max. load of 350 Ω is admissible.

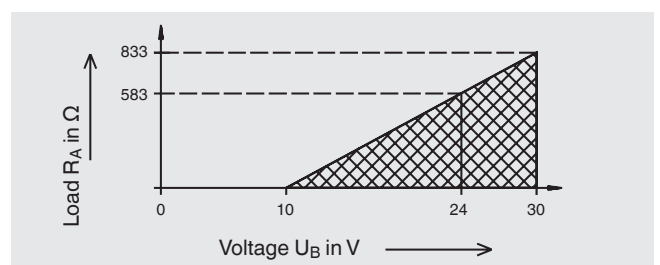

Explosion protection

Resistance thermometers of the TR34 series have an EC-type examination certificate for "intrinsically safe", Ex i, ignition protection.

These instruments comply with the requirements of 94/9/EC (ATEX) directive for gases and dusts.

The classification/suitability of the instrument (permissible power P_{max} as well as the permissible ambient temperature) for the respective category can be seen on the EC-type examination certificate and in the operating instructions.

CE conformity

EMC directive ¹⁾

2004/108/EC, EN 61326 emission (group 1, class B) and interference immunity (industrial application)

ATEX directive

94/9/EG, II 1G Ex ia IIC T1 - T6 Ga

II 1/2G Ex ia IIC T1 - T6 Ga/Gb

II 2G Ex ia IIC T1 - T6 Gb

II 1D Ex ia IIIC T135°C Da

II 1/2D Ex ia IIIC T135°C Da/Db

II 2D Ex ia IIIC T135°C Db

1) Only for built-in transmitter

Approvals (option)

- **IECEx**, ignition protection type "i" - intrinsic safety, ignition protection type "ID" - dust protection through intrinsic safety, international certification for the Ex area

Certificates (option)

Certification type	Measuring accuracy	Material certificate
2.2 test report	x	x
3.1 inspection certificate	x	x
DKD/DAkkS calibration certificate	x	-

The different certifications can be combined with each other.

Approvals and certificates, see website

Ordering information

Model / Explosion protection / Output signal / Transmitter temperature unit / Process temperature / Transmitter initial value / Transmitter end value / Process connection / Sensor diameter / Insertion length A (U₁) or A (U₂) / Neck length N (M_H) / Accessories / Certificates

© 2014 WIKA Alexander Wiegand SE & Co. KG, all rights reserved.
The specifications given in this document represent the state of engineering at the time of publishing.
We reserve the right to make modifications to the specifications and materials.

