

Hazardous Area Temperature and Pressure Switches

4250 Series

Overview

The 4250 Series is ideal for providing a quick action switch at set points on engine and compressor coolants systems, process control points, lubrication systems and alarm systems in hazardous duty locations. Well established and long proven pressure and temperature sensing methods enable precise and reliable operation largely unaffected by changes in ambient conditions. These units are inexpensive and easy to install since multifunction and dual switching types share common housings.

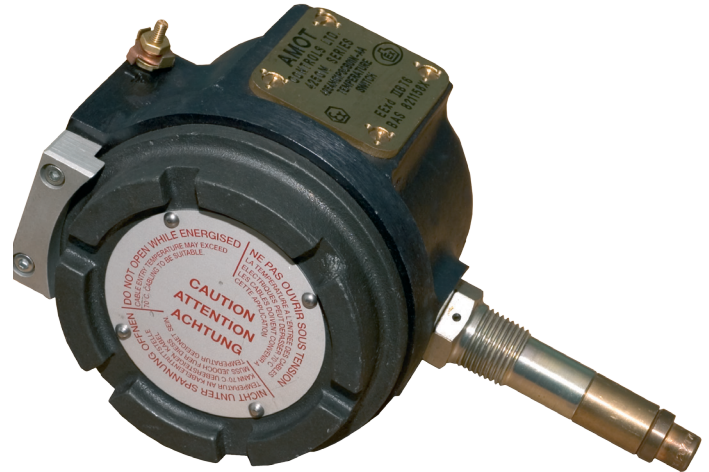

4250 Hazardous Area
Temperature and Pressure
Switch

Typical applications

Provides snap switch action at set points on:

- Engine coolant systems
- Process control points
- Alarm systems
- Compressor coolant systems
- Lubrication systems
- Hazardous area applications

Key features and benefits

- Flame proof protection - ATEX certified
-  II 2G Ex d IIB T6 Gb
II 2G Ex d IIB T5 Gb Ta -20°C to +55°C
II 2G Ex d IIB T4 Gb Ta -20°C to +80°C
- Single or dual pressure
- Single or dual temperature
- Snap acting

amot

www.amot.com

Hazardous Area Temperature and Pressure Switches - Series 4250

Operation

The 4250 Series is designed for use wherever explosion proof switches are needed to sense pressure or temperature. Several types are available for sensing dual temperatures, dual pressures or single pressure and temperature points. Pressure ranges from 0.34 - 17.2 bar (5-250 psi) and temperature ranges from

16-118°C (60-245 °F) are available. Well established and long proven pressure and temperature sensing methods enable precise and reliable operation largely unaffected by changes in ambient conditions. These units are easy to install since multi-function and dual switching types share common housings.

Model types

Model type	Description
4251	Pressure and temperature switch combination with two snap switches, one for the pressure set point and the other for temperature set point.
4252	Pressure switch with one switch for one pressure set point.
4253	Temperature switch with one switch for one temperature set point.
4254	Temperature switch with two switches, each independently adjustable, providing two temperature set points, within the limits of the chosen temperature range.
4255	Pressure switch with two switches, each independently adjustable, providing two pressure set points within the limits of the chosen pressure range.

Stainless steel well

Well part no.	Length mm	Code
3802L001	46.0	00
3802L003	65.0	01
3802L004	77.7	02
3802L005	90.4	03
3802L006	103.1	04
3802L007	115.8	05

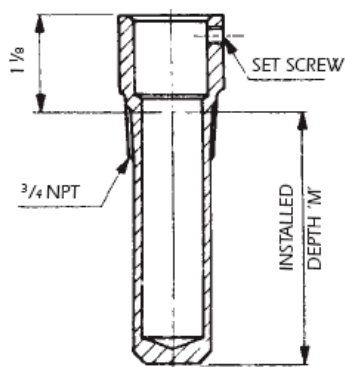

3802L steel well

A stainless steel well may be ordered with the type 4251, 4253 and 4254 switches as an option. The model 3802L well is usable for 340 bar (5000 psi) service and has a non-threaded bore with set screws for quick installation or removal of the switch. Wells and valves ordered at the same time will be assembled by AMOT using 40081 silicon heat transfer compound in the well. This is necessary to reduce the temperature lag experienced by controls when fitted to immersion wells. Lag will vary according to the fluid and flow conditions. Model 2766L well is also available for 681 bar (10,000 psi) service. Contact AMOT for details.

Hazardous Area Temperature and Pressure Switches - Series 4250

Specification

Housing material:	Cast aluminum	
Diaphragm:	Nitrile or Viton	
Maximum pressure on diaphragm:	24.1 Bar (350 psi)	
Maximum pressure on temperature element:	54.04 Bar (800 psi)	
Maximum case temp.:	40°C (T6)	104°F
	55°C (T5 - to special order)	131°F
	80°C (T4 - to special order)	176°F
Maximum net weight:	2.1 kg	4.6 lbs
Maximum shipping weight:	2.4 kg	5.4 lbs
EC type examination cert:	Baseefa03ATEX0633X, Baseefa03ATEX0633X/3	
ATEX Certification:	 The ATEX Directives detail equipment and work conditions allowable in an environment with an explosive atmosphere.	

Switch types, terminals and ratings

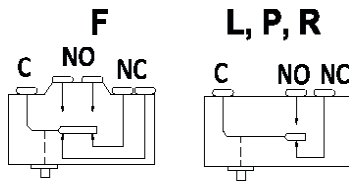

Voltage	AC		DC	
	Resistive	Inductive	Resistive	Inductive
15			15.0	10.0
30			5.0	5.0
50			1.25	1.25
75		15.0	0.25	0.30
125	15.0	15.0	0.75	0.05
250	15.0	5.0	0.50	0.03
380	15.0	4.0	0.25	
480	15.0			

Pressure range falling pressure in PSI	Pressure differential in PSI		
	Type R, F	Type P	Type L
5 - 25	4 ± 2	1.5 ± 1	6 ± 2
15 - 75	9 ± 3	4 ± 2	12 ± 3
45 - 125	13 ± 4	7 ± 3	16 ± 4

Pressure ranges shown indicate switch settings on falling pressure. For rising pressure, add the particular switch differential to the falling range limits shown.

Temp. range °C	Temperature differential in °C		
	Type R, F	Type P	Type L
15.6-35.0	1.62 ± 1	1 ± .5	2.16 ± 1
35.5-54.4	2.16 ± 1	1.62 ± .5	2.70 ± 1
55.0-71.1	2.90 ± 1	2.16 ± .5	3.24 ± 1
71.6-82.2	2.70 ± 1	2.16 ± .5	3.24 ± 1
82.7-98.9	2.70 ± 1	2.16 ± .5	3.24 ± 1
101.7-107.2	2.16 ± 1	1.62 ± .5	2.78 ± .5
107.7-118.3	2.70 ± 1	N/A	3.24 ± .5

Temp. range °F	Temperature differential in °F		
	Type R, F	Type P	Type L
60 - 95	3 ± 2	2 ± 2	4 ± 2
96 - 130	4 ± 2	3 ± 1	5 ± 2
131 - 160	5 ± 2	4 ± 1	6 ± 2
161 - 180	5 ± 2	4 ± 1	6 ± 2
181 - 210	5 ± 2	4 ± 1	6 ± 2
215 - 225	4 ± 2	3 ± 1	5 ± 1
226 - 245	5 ± 1	4 ± 1	6 ± 1

Temperature ranges shown indicate settings on rising temperature. For falling temperatures subtract the particular switch differential from the given range. Temperature differentials are generally greater at the low end of a range.

Hazardous Area Temperature and Pressure Switches - Series 4250

Dimensions

Pressure/temperature model 4251

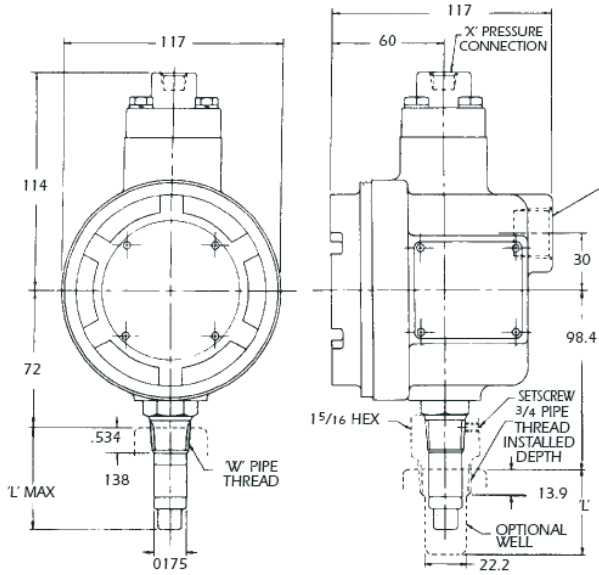

Temperature model 4253, 4254

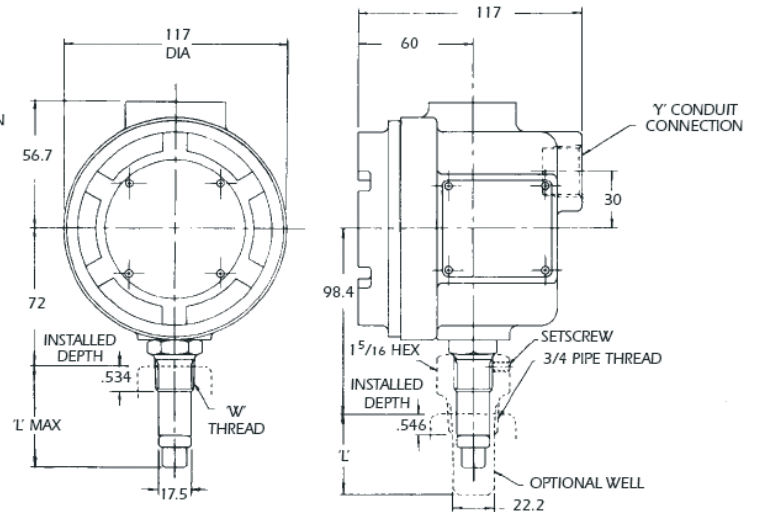

Pressure model 4252, 4255

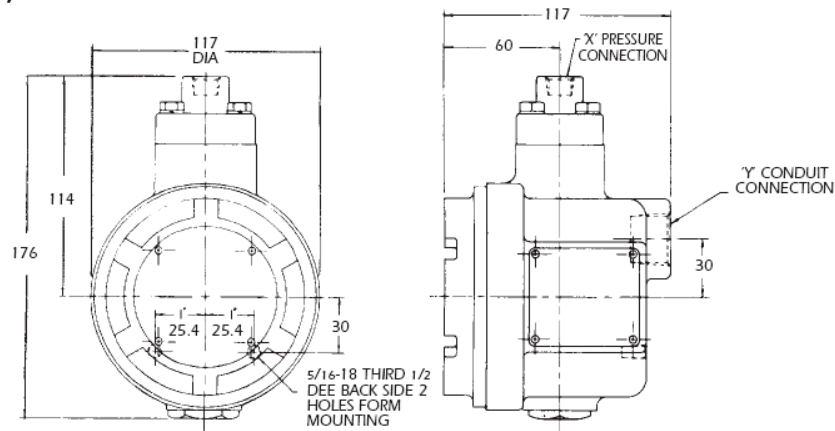

Dimensions in mm

Connections for all models		
'W' pipe thread	'X' pressure connection	'Y' conduit connection
1/2 NPT	1/4 NPT	3/4 NPT
1/2 BSP taper	1/4 BSP PL	M20 x 2.5
DIN 2999 R1/2 (1/2 BSP taper)	DIN 2999 R1/4 (1/4 BSP PL)	DIN 40 430 PG 13.5
DIN 2999 R1/2 (1/2 BSP taper)	DIN 2999 R1/4 (1/4 BSP PL)	DIN 40 430 PG 16

Hazardous Area Temperature and Pressure Switches - Series 4250

How to order

Use the tables below to select the unique specification of your Model 4250 Temperature and Pressure Switch:

Example: **A** **B** **C** **D** **E** **F** **G** **HH** **K** **LL**

Example: 4251M 2 2 L 6 C D 99 V - AA

A	Base Model
4251M	Pressure/Temperature (Pressure ranges 1-3 only)
4252M	Single Pressure
4253M	Single Temperature
4254M	Dual Temperature
4255M	Dual Pressure

B	Pressure Range	
	Bar	PSI
1	0.34 - 1.72	5 - 25
2	1.03 - 5.17	15 - 75
3	3.10 - 8.62	45 - 125
4	5.52 - 17.24	80 - 250
0	Non-Pressure version	

C	Seal Material
1	Buna N
2	Viton

D	Microswitch Type
F	Split Contact - Temperatures 1 - 6
L	High DC current - Temperatures 1 - 6
P	As "R", High Temp - Temperatures 1 - 7
Q	Double break low differential - Temperatures 1 - 7
R	Standard - Temperatures 1 - 6 only

E	Temperature			
	Without Well		With Well	
	°C	°F	°C	°F
1	15-35	60-95	21-40	70-105
2	35-54	96-130	41-60	106-140
3	55-71	131-160	60-76	141-170
4	71-82	161-180	77-88	171-190
5	83-99	181-210	88-104	191-220
6	101-107	215-225	107-113	225-235
7	108-118	226-245	113-124	236-255
0	Non-Temperature Version			

F	Thread Finish
A	NPT Standard Finish
B	NPT Gulfproof (Anodized + epoxy paint) Finish
C	BSP* Standard Finish
D	BSP* Gulfproof (Anodized + epoxy paint) Finish

*Note: BSP gives parallel thread on pressure bonnet, taper thread on temperature extension.

G	Conduit Thread
A	NPT
B	M20
C	PG 13.5
D	PG 16

HH	Temperature Element Extension	
	mm	inches
00	55.56	2 3/16
01	77.78	3 1/16
02	84.14	3 5/16
03	96.84	3 13/16
04	109.54	4 5/16
05	122.24	4 13/16
06	134.94	5 5/16
07	147.64	5 13/16
08	239.70	9 7/16
99	Non-Temperature Version	

K	Calibration Option
V	Calibrated for use with thermowell
N	Pressure version (Not thermowell calibrated)

LL	Customer Special Options
AA	Standard
***	Contact factory for any special requirements

Americas

AMOT USA
8824 Fallbrook Dr
Houston
TX 77064
USA

Tel: +1 (281) 940 1800
Fax +1 (713) 559 9419
Email sales@amotusa.com

Asia Pacific

AMOT Shanghai
Rm 4102 - 4104 United Plaza
1468 Nanjing Road West
Shanghai 200040
China

Tel +86 (0) 21 6279 7700
Fax +86 (0) 21 5237 8560
Email shanghai@amot.com

AMOT Singapore
10 Eunos Road 8 #12-06
Singapore Post Centre
Singapore 408600

Tel +65 6408 6265
Fax +65 6293 3307
Email singapore@amot.com

Europe and Africa

AMOT
Western Way
Bury St Edmunds
Suffolk, IP33 3SZ
England

Tel +44 (0) 1284 762222
Fax +44 (0) 1284 760256
Email info@amot.com

AMOT Controls GmbH
Rondenbarg 25
22525 Hamburg
Germany

Tel +49 (0) 40 8537 1298
Fax +49 (0) 40 8537 1331
Email germany@amot.com