

Threaded thermocouple Model TC10-C, with fabricated thermowell model TW35

WIKA data sheet TE 65.03



Applications

- Machine building, plant and vessel construction
- Energy and power plant technology
- Chemical industry
- Food and beverage industry
- Sanitary, heating and air-conditioning technology

Special features

- Application ranges from 0 ... 1,200 °C
- Model TW35 fabricated thermowell included
- Spring-loaded measuring insert (replaceable)
- Explosion-protected versions Ex i and NAMUR NE24

Description

Thermocouples of this series are designed for screw-fitting directly into the process, mainly in vessels and pipelines. These thermometers are suitable for liquid and gaseous media under moderate mechanical load and normal chemical conditions.

The thermowell model TW35 made of stainless steel is all welded and screwed into the connection head. The interchangeable measuring insert can be removed without taking out the complete probe from the plant. This enables inspection, verification of the measuring chain and, when servicing is necessary, replacement during operation and while the plant is running. The choice of standard lengths assists with short delivery times and the possibility of stocking spare parts.



Threaded thermocouple, model TC10-C with fabricated thermowell, model TW35

Insertion length, process connection, thermowell design, connection head, type and number of sensors, accuracy and method of connection can each be selected to suit the respective application.

Optionally we can fit analogue or digital transmitters from the WIKA range into the connection head of the TC10-C.

Sensor

Sensor types

Model	Recommended max. operating temperature
K	1,200 °C
J	800 °C
E	800 °C
T	400 °C
N	1,200 °C

Thermocouple Model	Class	DIN EN 60584 part 2	ASTM 14.03 E230
K	1 and 2		Standard, special
J	1 and 2		Standard, special
N	1 and 2		-
E	1 and 2		-
T	1 and 2		-

Tolerance value

For the tolerance value of thermocouples, a cold junction temperature of 0 °C has been taken as the basis.

For detailed specifications for thermocouples, see Technical information IN 00.23 at www.wika.com.

Listed models are available both as single or dual thermocouples. The thermocouple will be delivered with an insulated measuring point, unless explicitly specified otherwise.

The actual application range of these thermometers is limited both by the permissible maximum temperature of the thermocouple and the sheath material as well as by the permissible maximum temperature of the thermowell material.

Standard measuring insert lengths

Measuring insert Ø in mm	Standard measuring insert lengths in mm										
3	275	315	375	435							
6	275	315	345	375	405	435	525	555	585	655	735
8	275	315	345	375	405	435	525	555	585	655	735

The lengths specified in this table correspond to the standard lengths. Intermediate lengths or greater lengths are possible without any difficulty.

Measuring insert

The measuring insert is made of a vibration-resistant, sheathed, mineral-insulated cable (MI cable).

The diameter of the measuring insert should be approx. 1 mm smaller than the bore diameter of the thermowell.

Gaps of more than 0.5 mm between thermowell and the measuring insert will have a negative effect on the heat transfer, and they will result in unfavourable response behaviour from the thermometer.

In order to ensure that the measuring insert is firmly pressed down onto the bottom of the thermowell, the insert must be spring-loaded (spring travel: max 10 mm).

The standard material used for the measuring insert sheath is stainless steel. Other materials on request.

Components model TC10-C

Fig. with parallel thread, for tapered thread see "Dimensions in mm"

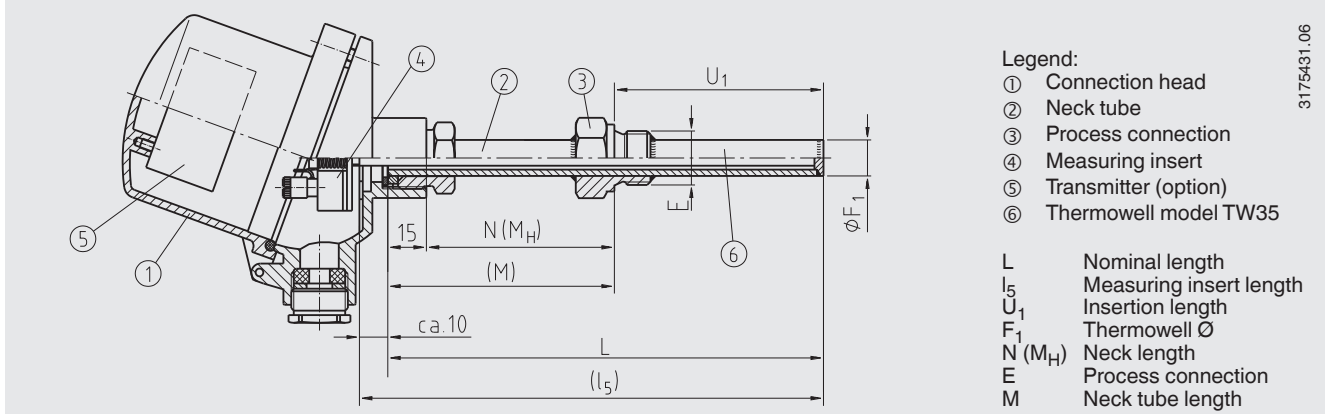

Thermowell model TW35

The thermowell is made of drawn tube with a welded bottom and is screwed into the connection head. The cable outlet can be aligned by rotating the connection head.

The process connection, in accordance with the customer specification, is welded onto the thermowell in the factory, which also fixes the insertion length. Insertion lengths to DIN standards are preferable.

Designs to DIN standards and also special designs (e.g., with tapered thermowell, reinforced neck tube, etc.) are available in 1.4571 stainless steel or special materials on request.

For further technical specifications on the thermowell please see WIKA data sheet TW 95.35.

Design of thermowell model TW35

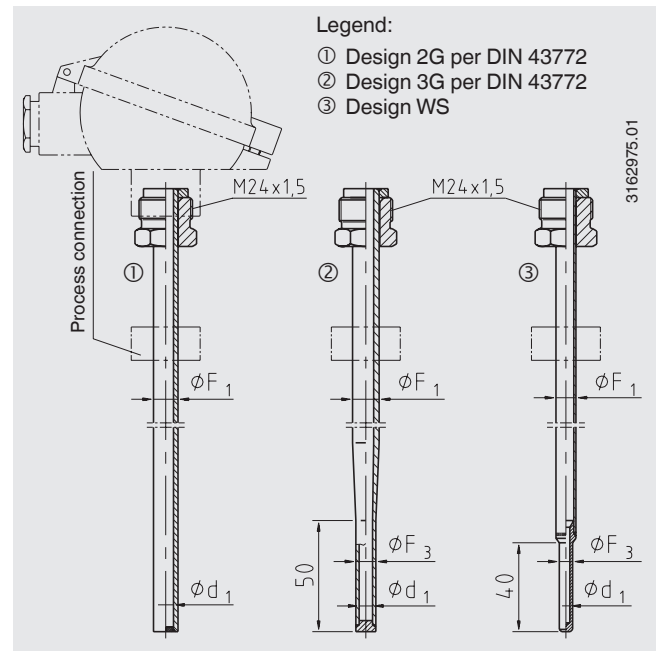

Versions per DIN 43772

Design	Insertion length	Process connection	Thermowell outer ϕF_1	Thermowell outer ϕ at tip F_3	Thermowell inner ϕ at tip d_1	Neck length N
Design 2G	160	G 1/2 B, G 1 B	9, 11, 12, 14	-	-	130
Design 2G	250	G 1/2 B, G 1 B	9, 11, 12, 14	-	-	130
Design 2G	400	G 1/2 B, G 1 B	9, 11, 12, 14	-	-	130
Design 3G	160	G 1/2 B, G 1 B	12	9 + 0.2	6 + 0.1 / - 0.05	132
Design 3G	220	G 1/2 B, G 1 B	12	9 + 0.2	6 + 0.1 / - 0.05	132
Design 3G	280	G 1/2 B, G 1 B	12	9 + 0.2	6 + 0.1 / - 0.05	132
Design 3G	160	G 1/2 B, G 1 B	14	11 + 0.2	8 + 0.1 / - 0.05	132
Design 3G	220	G 1/2 B, G 1 B	14	11 + 0.2	8 + 0.1 / - 0.05	132
Design 3G	280	G 1/2 B, G 1 B	14	11 + 0.2	8 + 0.1 / - 0.05	132

Above designs are also available with 1/2 NPT process connections. In this case, however, these will not conform to DIN 43772.

Versions not to standards

Design	Insertion length	Process connection	Thermowell outer ϕF_1	Thermowell outer ϕ at tip F_3	Thermowell inner ϕ at tip d_1	Neck length N
Design WS	160	G 1/2 B, G 1 B, 1/2 NPT	9, 11, 12	6	3.5	130
Design WS	220	G 1/2 B, G 1 B, 1/2 NPT	9, 11, 12	6	3.5	130
Design WS	250	G 1/2 B, G 1 B, 1/2 NPT	9, 11, 12	6	3.5	130
Design WS	280	G 1/2 B, G 1 B, 1/2 NPT	9, 11, 12	6	3.5	130
Design WS	400	G 1/2 B, G 1 B, 1/2 NPT	9, 11, 12	6	3.5	130

Process connection

Screw type:

- Male thread, welded with thermowell
- Compression fitting, primarily with 12 mm diameter thermowells
(Compression fittings allow simple adjustment to the required insertion length at the installation point. After tightening, the compression fitting can no longer be moved along the thermowell.)

Dimensions in mm

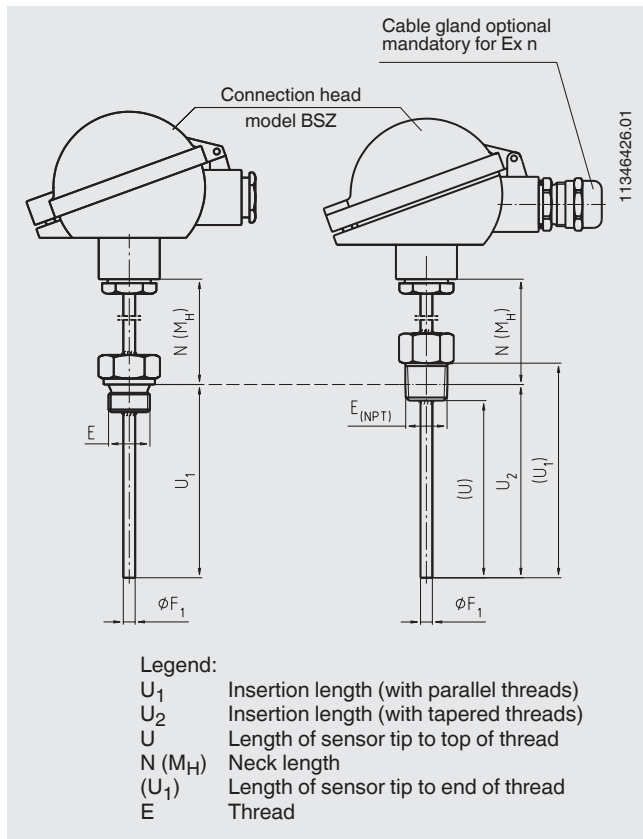

Thermowell diameter	9 mm	11 mm	12 mm	14 mm
Threaded connection				
G 1/2 B	G 1/2 B	G 1/2 B	G 1/2 B	G 1/2 B
-	G 1 B	G 1 B	G 1 B	G 1 B
1/2 NPT	1/2 NPT	1/2 NPT	1/2 NPT	1/2 NPT
M20 x 1.5	M20 x 1.5	M20 x 1.5	M20 x 1.5	M20 x 1.5
Compression fitting				
-	-	G 1/2 B	-	-
-	-	1/2 NPT	-	-

Connection head

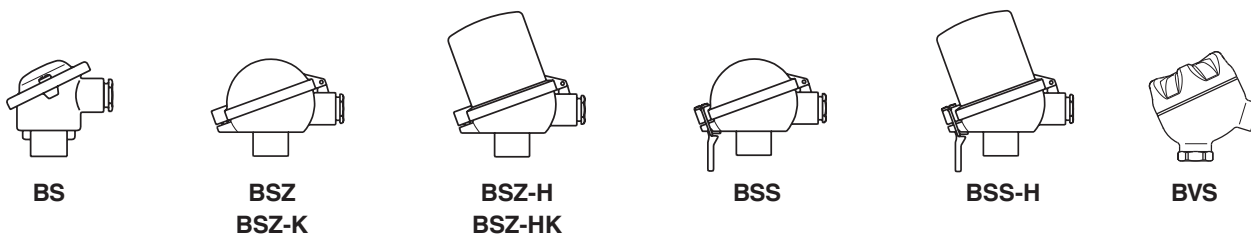

Model	Material	Cable outlet	Ingress protection	Cap	Surface
BS	Aluminium	M20 x 1.5 ¹⁾	IP 65	Cap with 2 screws	Blue, lacquered ²⁾
BSZ	Aluminium	M20 x 1.5 ¹⁾	IP 65	Hinged cover with cylinder head screw	Blue, lacquered ²⁾
BSZ-K	Plastic	M20 x 1.5 ¹⁾	IP 65	Hinged cover with cylinder head screw	Black
BSZ-H	Aluminium	M20 x 1.5 ¹⁾	IP 65	Hinged cover with cylinder head screw	Blue, lacquered ²⁾
BSZ-HK	Plastic	M20 x 1.5 ¹⁾	IP 65	Hinged cover with cylinder head screw	Black
BSS	Aluminium	M20 x 1.5 ¹⁾	IP 65	Hinged cover with clip	Blue, lacquered ²⁾
BSS-H	Aluminium	M20 x 1.5 ¹⁾	IP 65	Hinged cover with clip	Blue, lacquered ²⁾
BVS	Stainless steel	M20 x 1.5 ¹⁾	IP 65	Screw cover	Precision casting, electropolished

1) Standard
2) RAL 5022

Connection head with digital indicator (option)

As an alternative to the standard connection head the thermometer can be fitted with an optional DIH10 digital indicator. The connection head used for this is similar to the model BSZ-H head. For operation, a 4 ... 20 mA transmitter is needed, which is mounted to the measuring insert. The indication range is configured identically to the measuring range of the transmitter.

Designs with ignition protection type "intrinsically safe", Ex i, are also available.



Connection head with digital indicator, model DIH10

Transmitter (option)

Depending on the connection head used, a transmitter can be mounted within the thermometer.

- Mounted instead of terminal block
- Mounted within the cap of the connection head
- Mounting not possible

Connection head	Transmitter model		
	T12	T32	T53
BS	-	-	○
BSZ / BSZ-K	○	○	○
BSZ-H / BSZ-HK	●	●	●
BSS	○	○	○
BSS-H	●	●	●
BVS	○	○	○

Mounting of 2 transmitters on request.

Model	Description	Explosion protection	Data sheet
T12	Digital transmitter, PC configurable	Optional	TE 12.03
T32	Digital transmitter, HART® protocol	Optional	TE 32.04
T53	Digital transmitter FOUNDATION™ Fieldbus and PROFIBUS® PA	Standard	TE 53.01

Electrical connection

Single thermocouple

Dual thermocouple

The colour coding at the positive poles of the instrument decides the correlation of polarity and connection terminal.

For the electrical connections of built-in temperature transmitters see the corresponding data sheets or operating instructions.

Explosion protection (optional)

Thermocouples of the TC10-C series with model TW35 thermowell are available with an EC-type examination certificate for "intrinsically safe", Ex i, ignition protection. These instruments comply with the requirements of 94/9/EC (ATEX) directive for gas and dust. Versions in accordance with NAMUR NE24 are also possible.

The classification/suitability of the instrument (permissible power P_{max} as well as the permissible ambient temperature) for the respective category can be seen on the EC-type examination certificate and in the operating instructions.

Built-in transmitters have their own EC-type examination certificate. The permissible ambient temperature ranges of the built-in transmitters can be taken from the corresponding transmitter approval.

CE conformity

EMC directive ¹⁾

2004/108/EC, EN 61326 emission (group 1, class B) and interference immunity (industrial application)

ATEX directive (option)

94/9/EC, EN 60079-0, EN 60079-11, EN 60079-26, EN 61241-11

1) Only for built-in transmitter

Approvals (option)

- **IECEX**, ignition protection type "i" - intrinsic safety, ignition protection type "iD" - dust protection through intrinsic safety, international certification for the Ex area
- **NEPSI**, ignition protection type "i" - intrinsic safety, ignition protection type "iD" - dust protection through intrinsic safety, ignition protection type "n", China
- **GOST-R**, import certificate, ignition protection type "i" - intrinsic safety, ignition protection type "iD" - dust protection through intrinsic safety, Russia
- **KOSHA**, ignition protection type "i" - intrinsic safety, ignition protection type "iD" - dust protection through intrinsic safety, South Korea
- **PESO (CCOE)**, ignition protection type "i" - intrinsic safety, ignition protection type "iD" - dust protection through intrinsic safety, India

Certificates (option)

Certification type	Measuring accuracy	Material certificate
2.2 test report	x	x
3.1 inspection certificate	x	x
DKD/DAkkS calibration certificate	x	-

The different certifications can be combined with each other.

Approvals and certificates, see website

Ordering information

Model / Explosion protection / Sensor / Class accuracy / Connection head / Transmitter / Thermowell / Process connection / Wetted-parts materials / Neck length N(M_H) / Certificates / Options

© 2003 WIKA Alexander Wiegand SE & Co. KG, all rights reserved.
The specifications given in this document represent the state of engineering at the time of publishing.
We reserve the right to make modifications to the specifications and materials.

