

Technical brochure

# Product temperature sensor type AK-HS 1000



Pt 1000 product temperature sensor.

The sensor is developed for temperature monitoring and data logging in HACCP system. It has been designed to simulate a product placed in a refrigeration application. Hereby a realistic HACCP report is achieved.

Together with an ADAP-KOOL® appliance control the HACCP tolerance requirement of  $\pm 1$  K in the whole area is complied with in the whole range of  $-30^{\circ}\text{C}$  to  $+15^{\circ}\text{C}$ .

## Temperature sensor type AK-HS 1000

### Technical data

Nominal resistance	1000 ohm at 0°C
Measuring accuracy	EN 60751 Class B
Temperature range	-30 to 50°C
Cable material	PVC 2 × 0.25 mm <sup>2</sup>
Sensor cover Sensor bottom	ABS PC (polycarbonate)
Enclosure	IP 54
Time constant in air	T90 = 3-15 min.

R (Typ.) Ohm	Temp. °C	Temp. °F
1117	30	86
1078	20	68
1039	10	50
1000	0	32
961	-10	14
922	-20	-4
882	-30	-22

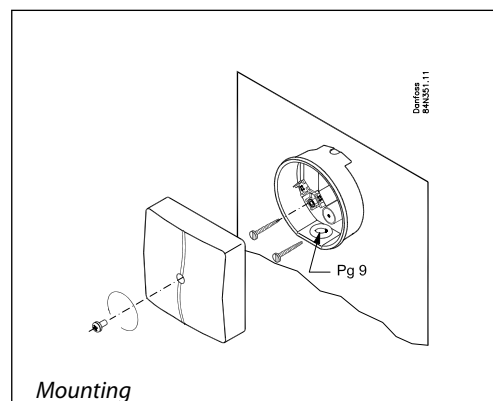
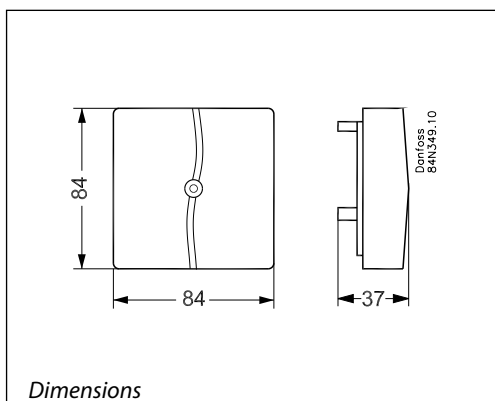

### Ordering

Type	Cable length	Weight approx.	Number	Code no.
AK-HS 1000	5.5 m	200 g	1 pcs.	084N1007
				084N1022*

\* This type is certified for controllers with non-galvanic separated power supply

If the cabled is lengthened, length and cable square must match so that the overall HACCP requirements of  $\pm 1$  K are complied with.

