



SERVICE BULLETIN

Model E Service Kit

When performance is on the line, rely on AMOT parts!

Valve Overview:

AMOT Model E Thermostatic Valves are 3-way, fully automatic fluid temperature controllers. These valves are suitable for process control and industrial applications where fluids must be mixed or diverted depending on their temperatures. They are used for reliable, automatic control of fluid temperatures in turbines, compressors and engine jacket water and lubricating oil cooling systems, as well as cogeneration systems.

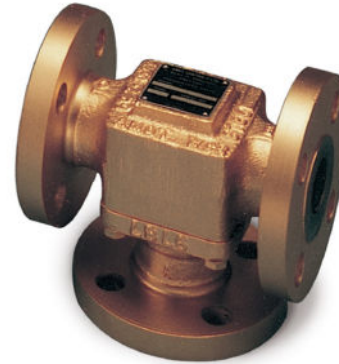

Maintenance & Servicing:

When properly applied and installed, AMOT Model E Thermostatic Valves require minimal maintenance. Field adjustments are not required as the operating temperature of each valve is permanently set at the factory by trained technicians. Once installed, this valve will provide years of trouble-free service.

Over time, exposure to foreign chemicals and particulate matter as well as prolonged operation at extreme temperatures, pressures and flows may reduce the effectiveness of your control valve. At such time, AMOT thermostatic valves can be restored to original performance simply by installing an AMOT Thermostatic Valve Service Kit. Service Kits include all new thermostatic elements and seals and can be easily installed by unbolting the valve housing.

AMOT recommends servicing of thermostatic control valves with each regularly scheduled major overhaul of your turbine, engine, compressor or other associated equipment.

Thermostatic Service Kits may also be used for adapting valves to new service temperatures.

Service Kit Identification:

AMOT Thermostatic Valve Service Kit model numbers closely follow the valve model numbers for which they are associated.

First, identify your valve model, located on the valve nameplate. An example is shown below for a valve with model number 1 1/2ELCT16003A-RRZ

Example Valve:

A	B	C	D	E	F	G	-H
1 1/2	EL	C	T	160	03	A	-RRZ

- A – Size
- B – Configuration
- C – Body Material
- D – Connection Type
- E – Temp (°F)
- F – Element/Seal Material
- G – Leak Hole
- H – Special (only as req'd)

For the corresponding Model E Service Kit, use the valve model, except omit the Size (A), and replace the Body Material (C) and Connection (D) with “KIT-“. The corresponding service kit becomes:

A	B	C	D	E	F	G	-H
	EL	KIT-		160	03	A	-RRZ

In addition, some AMOT valves will contain “-00-AA” or “-0-AA” in the suffix location (H). These two suffixes should be omitted from the Service Kit number.

Additional Examples as follows:

Valve Model	Corresponding Service Kit
1 1/2EFCF11001-RBA	EFKIT-11001-RBA
1 1/2EMSH14008D	EMKIT-14008D
1 1/2ELCT11001-RFZ	ELKIT-11001-RFZ
1 1/2EFSJ11004	EFKIT-11004
1 1/2ELCT19003-B7	ELKIT-19003-B7
1 1/2EOBT09510-00-AA	EOKIT-09510

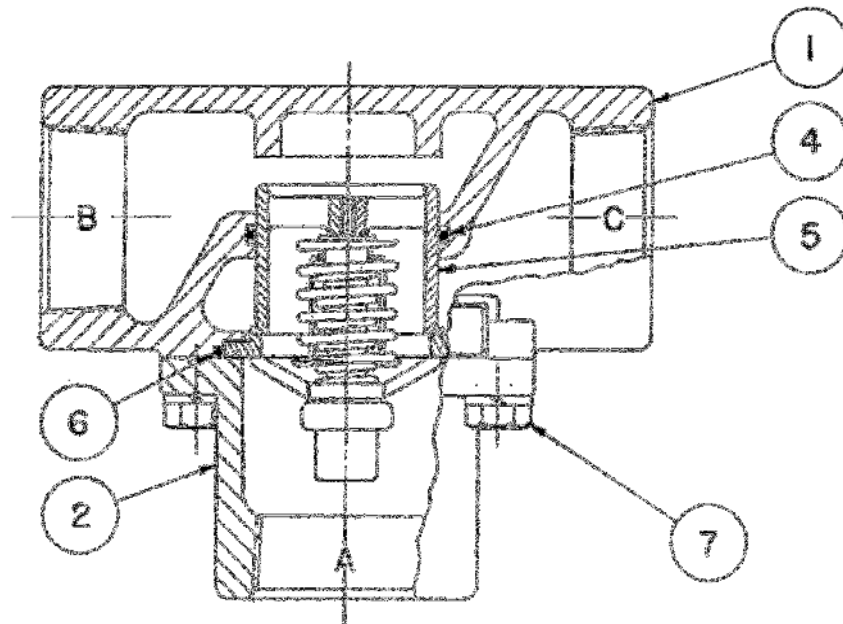

Model E Service Kit Installation:

The following instructions are for servicing a valve which has already been removed from service, cleaned and prepped. Consult the Primary Equipment OEM's Operation and Maintenance Manual for instructions on lock-out equipment, isolation and removal of the thermostatic control valve.

- 1) Remove Bolts ⑦ and separate the upper and lower housings.
- 2) Remove Element Assembly ⑤ and Element O-Ring Seal ④.
- 3) Remove Housing O-Ring (Gasket* in earlier versions) and clean any foreign material from sealing surfaces.
- 4) Lubricate new Element O-Ring Seal ④ with a good grade of petroleum grease and insert in the grooved sleeve in the Upper Housing ①.
- 5) Insert Element Assembly ⑤ through Element Seal ④ with a twisting motion.
- 6) Install housing seal O-Ring ⑥, or Housing Gasket, around the Element Assembly Flange
- 7) Bolt on Lower Housing ②.

***NOTE:** Some Service Kits are supplied with BOTH Housing **O-Rings** and Housing **Gaskets**. Replace your original housing seal using only the same style seal, and discard the extra component. Do NOT attempt to install both the O-Ring AND the gasket, or the seal will fail. If your valve was originally supplied with a gasket, do NOT attempt to use an O-Ring, as the seal will leak without a groove to accept the O-Ring.

Americas

AMOT Americas
 8824 Fallbrook Dr
 Houston, TX 77064 USA
 Tel +1 (281) 940 1800
 Fax +1 (713) 559 9419
 Email: sales@amotusa.com

Asia Pacific

AMOT Asia Pacific
 RM 4102 - 4104 United Plaza
 1468 Nanjing Road West
 Shanghai 200040 China
 Tel: +86 (0) 21 6279 7700
 shanghai@amot.com

Europe, Middle East & Africa

AMOT UK
 Western Way
 Bury St Edmunds
 Suffolk, IP33 3SZ, United Kingdom
 Tel: +44 (0) 1284 762222
 info@amot.com