

TW welded thermowell for general industrial applications.

APPLICATIONS

- For direct installation into the process.
- Machine building
- Pipelines and vessels
- Any other application where temperature instrumentation needs to be protected from the medium.

SPECIFICATIONS

Type

Welded thermowell

Available lengths

Any reasonable length with a minimum of 40 mm, measured from the start of the process connection.⁽¹⁾

Material

Stainless steel

Process connection and instrument connection

1/2" BSP standard, other connections on request.

⁽¹⁾See drawings for more info on lengths.



DESCRIPTION

Thermowells are particularly suitable for applications in which the measuring instrument is to be mounted directly into bored holes (e.g. in machine components) or directly into the process but there is a chemically aggressive medium or abrasion present in the process.

The thermowell will protect the measuring instrument from the aggressiveness or abrasion and therefore ensure a longer lifetime for the instrument. Another main advantage of using a thermowell is that in case of a failing sensor or thermometer, the instrument can be removed without interrupting the process. This decreases downtime and increases overall efficiency in the process.

These thermowells are made in Rotterdam. The close proximity to the port and our flexibility makes us a great option when speed, flexibility and quality are required. Thermowells made by TUVO are also an economical option, as we always keep innovating our production facility to ensure low prices.

FEATURES

- Mainly used for thermometers and temperature sensors.
- For insertion, screw-in with multiple process connection options.
- Threaded or sliding instrument connection.

DIAMETER COMBINATIONS						
Outside diameter (D)	6 mm	8 mm	10 mm	12 mm	15 mm	16 mm
Inside diameter	4 mm	6 mm	7 mm	8 mm	11 mm	13 mm
Wall thickness	1 mm	1 mm	1.5 mm	2 mm	1.5 mm	1.5 mm

VERSIONS

Model TW1 : Fixed thread connection

Model TW2: Sliding connection

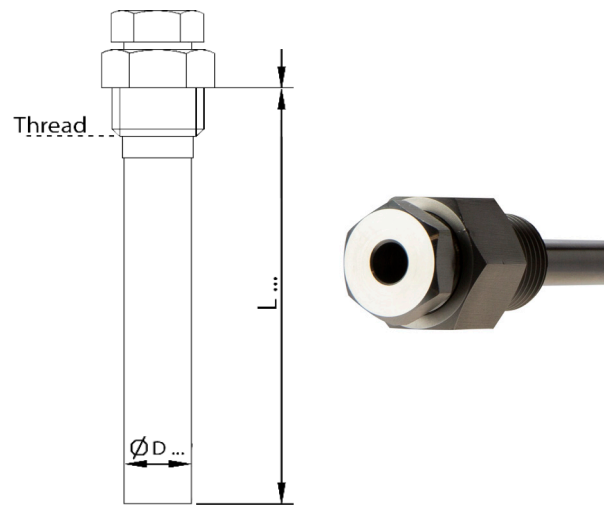
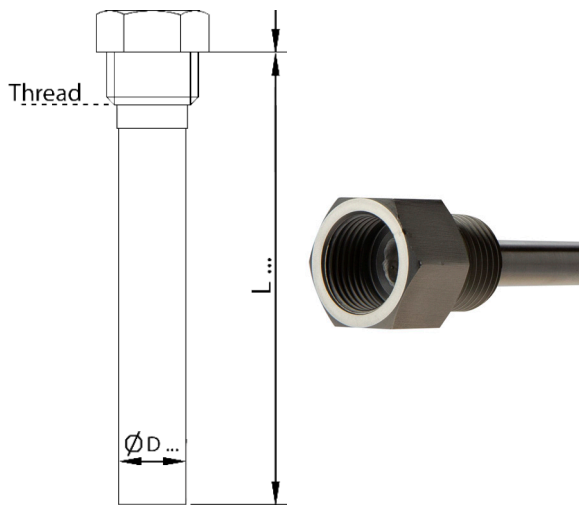

ORDER SHEET

Item	Code	Notes	XXX-	XXXX-	XXX	X
Instrument connection Fixed thread connection Sliding connection	TW1 TW2	G1/2" , others on request				
Outside diameter 6 mm 8 mm 10 mm 12 mm 15 mm 16 mm	64 86 107 128 1511 1613	4 mm inside diameter 6 mm inside diameter 7 mm inside diameter 8 mm inside diameter 11 mm inside diameter 13 mm inside diameter				
Insert length - L Specify length in mm (3 digits)	xxx					
Process connection G 1/2" 1/2" NPT M20 x 1,5 M27 x 2 G3/4" Other connection	X A B C D E Z	For Outside diameters; all diameters 6, 8, 12 mm 12 mm only 12 mm only 12 and 15 mm (Please specify!)				