

Field case for temperature transmitter Model TIF11

WIKA data sheet TE 62.02



Applications

- Plant construction
- Process engineering
- General industrial applications
- Energy and power plant technology
- Chemical industry, oil and gas

Special features

- Robust case designs
- Numerous connection options
- Large selection of temperature transmitters can be fitted
- Explosion-protected versions



Fig. left: Field case, round, with screw-on lid
Fig. right: Field case, rectangular

Description

Field cases of this series are available in various case variants. Plastic, stainless steel and aluminium versions can be specified. They can be combined with a large number of temperature transmitters.

Direct wall mounting is the standard fixing method for these field cases. An optional pipe mounting kit is also available for fitting to pipes with a diameter of 1 ... 2".

Explosion protection (option)

- TIF11-S (without explosion protection)
- TIF11-I (Ex i, intrinsically safe)
- TIF11-F (Ex d, with flameproof enclosure)

Cable entry	Explosion protection			
	without	Ex i (gas) Zone 0, 1, 2	Ex i (dust) Zone 20, 21, 22	Ex db (gas) Zone 1
Plastic cable gland	x	x	-	-
Plastic cable gland, Ex e (blue)	x	x	x	-
Plastic cable gland, Ex e (black)	x	x	x	-
Brass cable gland, nickel-plated	x	x	x	-
Brass cable gland, nickel-plated, Ex e	x	x	x	-
Stainless steel cable gland	x	x	x	-
Stainless steel cable gland, Ex e	x	x	x	-
Stainless steel cable gland, Ex d	-	-	-	x
Plain threaded	x	x	x ²⁾	x ²⁾
Junction box, M12 x 1 (4-pin)	x	x ¹⁾	x ¹⁾	-
Plug screw	x	x	x	x
Sealing plugs for transport	not applicable, transport protection			

For arrangement/suitability of cable glands to the cases, see page 9

Model	Approvals	Permissible ambient/storage temperature (in accordance with the relevant temperature classes)		
		With fitting of T15 and T16	With fitting of T32	With fitting of T53
TIF11-S	without	{-50} -40 ... +85 {+105} °C	{-60} ³⁾ / -40 ... +85 °C	-40 ... +85 °C
TIF11-F	Flameproof enclosure BVS 10 ATEX E 158 IECEX BVS 10.0103 II 2G Ex db IIC T4/T5/T6 Gb Ex db IIC T4/T5/T6 Gb	{-50} -40 ... +85 {+105} °C	T4: -40 ... +85 °C T5: -40 ... +75 °C T6: -40 ... +60 °C	T4: -40 ... +85 °C T5: -40 ... +60 °C T6: -40 ... +45 °C
TIF11-F	Flameproof enclosure TC RU C-DE.AЯ45.B.00010/18 1 Ex d IIC T6 ... T4 Gb X	T4: -40 ... +85 °C T5: -40 ... +70 °C T6: -40 ... +40 °C	T4: -60 ³⁾ / -40 ... +85 °C T5: -60 ³⁾ / -40 ... +75 °C T6: -60 ³⁾ / -40 ... +60 °C	T4: -40 ... +85 °C T5: -40 ... +75 °C T6: -40 ... +60 °C
TIF11-I	Intrinsically safe equipment ⁴⁾ BVS 16 ATEX E 112 X IECEX BVS 16.0075X II 2(1)G Ex ia [ia Ga] IIC T* Gb II 2(1)D Ex ia [ia Da] IIIC T135 °C Db	T4: -40 ... +85 °C (P _i = 800 mW) T5: -40 ... +70 °C (P _i = 800 mW) T6: -40 ... +55 °C (P _i = 800 mW) -40 ... +40 °C (P _i = 750 mW) -40 ... +75 °C (P _i = 650 mW) -40 ... +85 °C (P _i = 550 mW)	T4: -40 ... +85 °C (P _i = 800 mW) T5: -40 ... +70 °C (P _i = 800 mW) T6: -40 ... +55 °C (P _i = 800 mW) -40 ... +40 °C (P _i = 680 mW) -40 ... +70 °C (P _i = 650 mW)	T4: -40 ... +85 °C (P _i = 750 mW) T5: -40 ... +70 °C (P _i = 650 mW) T6: -40 ... +40 °C (P _i = 550 mW)

1) With appropriate mating connector connected

2) Suitable cable gland required for operation

3) Special version on request (only available without explosion protection or with specific approvals)

4) The installation conditions for the transmitters and displays must be considered for the final application.

Continued on next page

Model	Approvals	Permissible ambient/storage temperature (in accordance with the relevant temperature classes)		
		With fitting of T15 and T16	With fitting of T32	With fitting of T53
TIF11-I	Intrinsically safe equipment ⁴⁾ TC RU C-DE.AЯ45.B.00918 0 Ex ia IIC T4/T5/T6 Ga X 1 Ex ia IIC T4/T5/T6 Gb X Ex ia IIIC T80 ... T135 °C Da X Ex ia IIIC T80 ... T135 °C Db X	T4: -40 ... +85 °C (P _i = 750 mW) T5: -40 ... +70 °C (P _i = 650 mW) T6: -40 ... +40 °C (P _i = 550 mW)	T4: -60 ³⁾ / -40 ... +85 °C T5: -60 ³⁾ / -40 ... +70 °C T6: -60 ³⁾ / -40 ... +55 °C -60 ³⁾ / -40 ... +40 °C (P _i = 680 mW) -60 ³⁾ / -40 ... +70 °C (P _i = 650 mW)	T4: -40 ... +85 °C T5: -40 ... +75 °C T6: -40 ... +60 °C

³⁾ Special version on request (only available without explosion protection or with specific approvals)

⁴⁾ The installation conditions for the transmitters and displays must be considered for the final application.

With the installation of third-party products and/or transmitters with bus protocol:
 → see “Safety-related characteristics” for the respective transmitter

For ATEX/IECEx: third-party transmitter with own, suitable approval possible

GOST metrology for model TIF11 only applies when using a WIKA transmitter!

Safety-related characteristics (explosion-protected version) with built-in temperature transmitters

■ Model T15.x-AI

Intrinsically safe connection values for the current loop (4 ... 20 mA)

Protection level Ex ia IIC/IIB/IIA, Ex ia IIIC

Parameters	Model T15.x-AI	Model T15.x-AI
	Gas hazardous application	Dust hazardous application
Terminals	+ / -	+ / -
Voltage U_i	DC 30 V	DC 30 V
Current I_i	130 mA	130 mA
Power P_i	800 mW	750/650/550 mW
Effective internal capacitance C_i	18.4 nF	18.4 nF
Effective internal inductance L_i	20 μ H	20 μ H

Sensor circuit

Parameters		Model T15.x-AI
		Ex ia IIC/IIB/IIA Ex ia IIIC
Terminals		1 - 4
Voltage U_o		DC 30 V
Current I_o		6.1 mA
Power P_o		46 mW
Max. external capacitance C_o	IIC	30 nF ¹⁾
	IIB IIIC	0.520 μ F ¹⁾
	IIA	1.70 μ F ¹⁾
Max. external inductance L_o	IIC	1 mH
	IIB IIIC	1 mH
	IIA	1 mH
Characteristics		Linear

Ambient temperature range

Application	Ambient temperature range	Temperature class	Power P_i
Group II	$-40\text{ °C } (-40\text{ °F}) \leq T_a \leq +85\text{ °C } (+185\text{ °F})$	T4	800 mW
	$-40\text{ °C } (-40\text{ °F}) \leq T_a \leq +70\text{ °C } (+158\text{ °F})$	T5	800 mW
	$-40\text{ °C } (-40\text{ °F}) \leq T_a \leq +55\text{ °C } (+131\text{ °F})$	T6	800 mW
Group IIIC	$-40\text{ °C } (-40\text{ °F}) \leq T_a \leq +40\text{ °C } (+104\text{ °F})$	N / A	750 mW
	$-40\text{ °C } (-40\text{ °F}) \leq T_a \leq +75\text{ °C } (+167\text{ °F})$	N / A	650 mW
	$-40\text{ °C } (-40\text{ °F}) \leq T_a \leq +85\text{ °C } (+185\text{ °F})$	N / A	550 mW

N / A = not applicable

¹⁾ Internal L and C have already been considered

Comments:

U_o : Maximum voltage of any conductor against the other three conductors

I_o : Maximum output current for the least favourable connection of the internal current limiting resistors

P_o : $U_o \times I_o$ divided by 4 (linear characteristic)

■ Model T16.x-AI

Intrinsically safe connection values for the current loop (4 ... 20 mA)

Protection level Ex ia IIC/IIB/IIA, Ex ia IIIC

Parameters	Model T16.x-AI	Model T16.x-AI
	Gas hazardous application	Dust hazardous application
Terminals	+ / -	+ / -
Voltage U_i	DC 30 V	DC 30 V
Current I_i	130 mA	130 mA
Power P_i	800 mW	750/650/550 mW
Effective internal capacitance C_i	18.4 nF	18.4 nF
Effective internal inductance L_i	800 μ H	800 μ H

Sensor circuit

Parameters	Model T16.x-AI
	Ex ia IIC/IIB/IIA Ex ia IIIC
Terminals	1 - 2
Voltage U_o	DC 6.6 V
Current I_o	4 mA
Power P_o	10 mW
Characteristics	Linear

Due to distance requirements of the applied standards, the IS power and signal circuit as well as the IS sensor circuit shall be considered as being galvanically connected to each other.

Ambient temperature range

Application	Ambient temperature range	Temperature class	Power P_i
Group II	$-40\text{ °C } (-40\text{ °F}) \leq T_a \leq +85\text{ °C } (+185\text{ °F})$	T4	800 mW
	$-40\text{ °C } (-40\text{ °F}) \leq T_a \leq +70\text{ °C } (+158\text{ °F})$	T5	800 mW
	$-40\text{ °C } (-40\text{ °F}) \leq T_a \leq +55\text{ °C } (+131\text{ °F})$	T6	800 mW
Group IIIC	$-40\text{ °C } (-40\text{ °F}) \leq T_a \leq +40\text{ °C } (+104\text{ °F})$	N / A	750 mW
	$-40\text{ °C } (-40\text{ °F}) \leq T_a \leq +75\text{ °C } (+167\text{ °F})$	N / A	650 mW
	$-40\text{ °C } (-40\text{ °F}) \leq T_a \leq +85\text{ °C } (+185\text{ °F})$	N / A	550 mW

N / A = not applicable

Comments:

U_o : Maximum voltage of any conductor against the other three conductors

I_o : Maximum output current for the least favourable connection of the internal current limiting resistors

P_o : $U_o \times I_o$ divided by 4 (linear characteristic)

■ Model T32.xS

Explosion protection, power supply					
Model	Approvals	Permissible ambient/storage temperature (in accordance with the relevant temperature classes)	Safety-related maximum values for		Power supply U_B (DC) ³⁾
			Sensor (Connections 1 - 4)	Current loop (Connections ±)	
T32.xS.000	without	-60 ¹⁾ / -50 ²⁾ / -40 ... +85 °C	-	-	10.5 ... 42 V
T32.1S.0IS, T32.3S.0IS	EC-type examination certificate: BVS 08 ATEX E 019 X and IECEx certificate BVS 08.0018X ■ T32.1S Zones 0, 1: II 1G Ex ia IIC T4/T5/T6 Ga Zones 20, 21: II 1D Ex ia IIIC T120 °C Da Intrinsically safe in accordance with ATEX directive and IECEx scheme ■ T32.3S Zones 0, 1: II 2(1) G Ex ia [ia Ga] IIC T4/T5/T6 Gb Zones 20, 21: II 2(1) D Ex ia [ia Da] IIIC T120 °C Db Intrinsically safe in accordance with ATEX directive and IECEx scheme	Gas, category 1 and 2 -50 ²⁾ / -40 ... +85 °C (T4) -50 ²⁾ / -40 ... +75 °C (T5) -50 ²⁾ / -40 ... +60 °C (T6) Dust, category 1 + 2 -50 ²⁾ / -40 ... +40 °C ($P_i < 750$ mW) -50 ²⁾ / -40 ... +75 °C ($P_i < 650$ mW) -50 ²⁾ / -40 ... +100 °C ($P_i < 550$ mW)	$U_o = DC 6.5 V$ $I_o = 9.3 mA$ $P_o = 15.2 mW$ $C_i = 208 nF$ $L_i = negligible$ Gas, category 1 and 2 IIC: $C_o = 24 \mu F$ ⁴⁾ $L_o = 365 mH$ $L_o/R_o = 1.44 mH/\Omega$ IIA: $C_o = 1,000 \mu F$ ⁴⁾ $L_o = 3,288 mH$ $L_o/R_o = 11.5 \mu H/\Omega$ Category 1 and 2, gas IIB, dust IIIC $C_o = 570 mH$ ⁴⁾ $L_o = 1,644 mH$ $L_o/R_o = 5.75 mH/\Omega$	Gas, category 1 + 2 $U_i = DC 30 V$ $I_i = 130 mA$ $P_i = 800 mW$ $C_i = 7.8 nF$ $L_i = 100 \mu H$ Dust, category 1 + 2 $U_i = DC 30 V$ $I_i = 130 mA$ $P_i = 750/650/550 mW$ $C_i = 7.8 nF$ $L_i = 100 \mu H$	10.5 ... 30 V
T32.1S.0IS, T32.3S.0IS	Intrinsically safe equipment RU C-DE.Г508.B.02485 0 Ex ia IIC T4/T5/T6 1 Ex ib IIC T4/T5/T6 2 Ex ic IIC T4/T5/T6 Ex nA II T4/T5/T6 DIP A20 Ta 120 °C DIP A21 Ta 120 °C	-60 ¹⁾ / -50 ²⁾ / -40 ... +85 °C (T4) -60 ¹⁾ / -50 ²⁾ / -40 ... +75 °C (T5) -60 ¹⁾ / -50 ²⁾ / -40 ... +60 °C (T6)	$V_{oc} = 6.5 V$ $I_{sc} = 9.3 mA$ $P_{max} = 15.2 mW$ $C_a = 24 \mu F$ $L_a = 365 \mu H$	$V_{max} = DC 30 V$ $I_{max} = 130 mA$ $P_i = 800 mW$ $C_i = 7.8 nF$ $L_i = 100 \mu H$	10.5 ... 30 V

1) Special version on request (only available with specific approvals), not for rail mounting version T32.3S

2) Special version, not for rail mounting version T32.3S

3) Power supply input protected against reverse polarity; Load $R_A \leq (U_B - 10.5 V) / 0.023 A$ with R_A in Ω and U_B in V (without HART®)

On switching on, an increase in the power supply of 2 V/s is needed; otherwise the temperature transmitter will remain in a safe condition at 3.5 mA.

4) C_i already considered

■ Model T53.10

Explosion protection, power supply						
Model	Approvals	Permissible ambient/ storage temperature (in accordance with the relevant temperature classes)	Safety-related maximum values for			Power supply $U_B^{2)}$ / current consumption
			Current loop (connections 1 + 2)		Sensor (connections 3 - 6)	
T53.10.OIS	EC-type examination certificate: KEMA 06ATEX0148 Zone 0,1: II 1G Ex ia IIC T4/T5/T6 Zone 0,1: II 1D Ex iaD	-40 ... +85 °C (T4)	$U_i = DC 30 V$	$C_i = 2 nF$	$U_o = 5.7 V$ $I_o = 8.4 mA$ $P_o = 12 mW$ $C_o = 40 \mu F$ $L_o = 200 mH$	DC 9 ... 32 V/ < 11 mA
		-40 ... +75 °C (T5)	$I_i = 120 mA$	$L_i = 1 \mu H$		
		-40 ... +60 °C (T6)	$P_i = 0.84 W$			
		-40 ... +75 °C (T4)	$U_i = DC 30 V$	$C_i = 2 nF$		
		-40 ... +65 °C (T5)	$I_i = 300 mA$	$L_i = 1 \mu H$		
		-40 ... +45 °C (T6)	$P_i = 1.3 W$			
		-40 ... +85 °C (T1 ... T4)	$U_i = DC 17.5 V$	$C_i = 2 nF$		
		-40 ... +60 °C (T5)	(FISCO)	$L_i = 1 \mu H$		
		-40 ... +45 °C (T6)	$I_i = 250 mA$			
			$P_i = 2.0 W$			
		-40 ... +85 °C (T1 ... T4)	$U_i = DC 15 V$	$C_i = 2 nF$		
		-40 ... +60 °C (T5)	$I_i = 900 mA$	$L_i = 1 \mu H$		
		-40 ... +45 °C (T6)	$P_i = 5.32 W$			
T53.10.OIS	EC-type examination certificate: KEMA 06ATEX0148X Zone 0,1: II 2G (1)G Ex ib [ia] IIC T4/T5/T6	-40 ... +85 °C (T1 ... T4)	Linear barrier	$C_i = 2 nF$		
		-40 ... +65 °C (T5)	$U_i = 30 V$	$L_i = 1 \mu H$		
		-40 ... +45 °C (T6)	$I_i = 120 mA$			
			$P_i = 0.84 W$			
		-40 ... +85 °C (T1 ... T4)	Trapezoid barrier	$C_i = 2 nF$		
		-40 ... +75 °C (T5)	$U_i = 30 V$	$L_i = 1 \mu H$		
		-40 ... +60 °C (T6)	$I_i = 300 mA$			
			$P_i = 1.3 W$			

1) Depending on the safety-relevant maximum values for the current loop circuit (for this, also see the type examination certificate).

Instrument versions



Specifications	Case	
	Round, with screw-on lid (head 5/6000 F, 5/6000 S)	Rectangular
Material	<ul style="list-style-type: none"> ■ Aluminium ■ Stainless steel 	<ul style="list-style-type: none"> ■ Polyester ■ Aluminium ■ Stainless steel
Surface	Aluminium: Blue, lacquered (RAL 5022) Stainless steel: Natural finish	Blank
Cable outlet thread size	<ul style="list-style-type: none"> ■ M20 x 1.5 ■ ½ NPT 	M20 x 1.5 others on request
IP ingress protection (max.)	IP66	IP66
Explosion protection	Ex i, Ex d	Ex i

Dimensions in mm

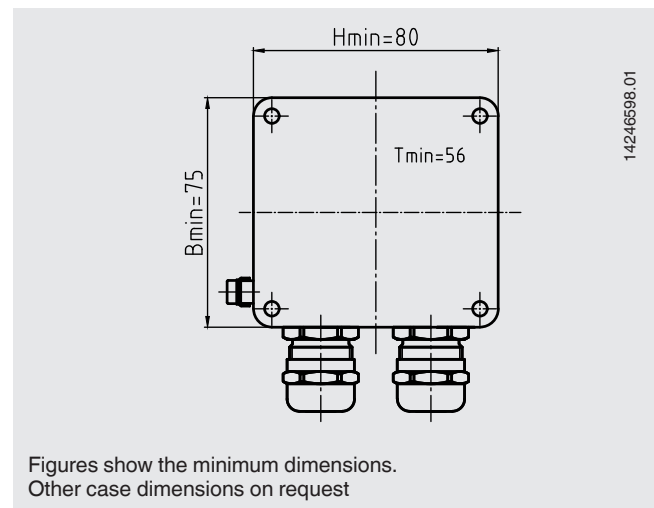
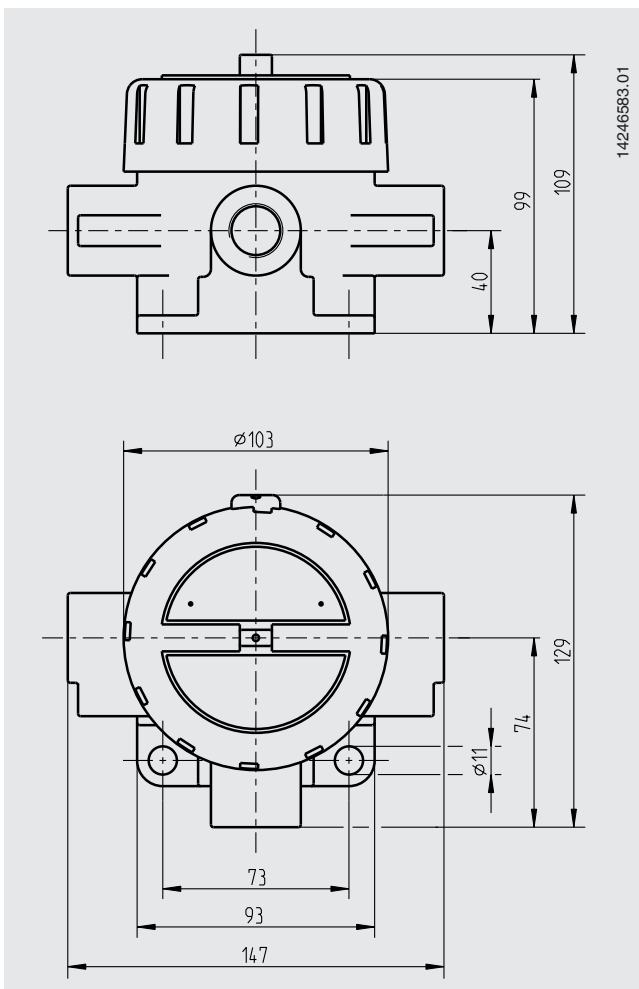

Cable entry



Cable entry	For cable Ø	Thread size	Colour	Ingress protection (max.)	Min./max. ambient temperature
Plastic cable gland	6 ... 10 mm	M20 x 1.5	Black or grey	IP66	-40 ... +80 °C
Plastic cable gland, Ex e	6 ... 10 mm	M20 x 1.5	Light blue	IP66	-20 ... +80 °C (standard) -40 ... +70 °C (option)
Plastic cable gland, Ex e	6 ... 10 mm	M20 x 1.5	Black	IP66	-20 ... +80 °C (standard) -40 ... +70 °C (option)
Brass cable gland, nickel-plated	6 ... 12 mm	M20 x 1.5 or ½ NPT	Blank	IP66	-60 ¹⁾ / -40 ... +80 °C
Brass cable gland, nickel-plated, Ex e	6 ... 12 mm	M20 x 1.5 or ½ NPT	Blank	IP66	-60 ¹⁾ / -40 ... +80 °C
Stainless steel cable gland	7 ... 12 mm	M20 x 1.5 or ½ NPT	Blank	IP66	-60 ¹⁾ / -40 ... +80 °C
Stainless steel cable gland, Ex e	7 ... 12 mm	M20 x 1.5 or ½ NPT	Blank	IP66	-60 ¹⁾ / -40 ... +80 °C
Stainless steel cable gland, Ex d	7 ... 12 mm	M20 x 1.5 or ½ NPT	Blank	IP66	-60 ¹⁾ / -40 ... +80 °C
Plain threaded	-	M20 x 1.5 or ½ NPT	-	IP00	-
Junction box, M12 x 1 (4-pin)	-	M20 x 1.5	-	IP65	-40 ... +80 °C
Plug screw	-	M20 x 1.5 or ½ NPT	Blank	IP66	-60 ... +80 °C
Sealing plugs for transport	-	M20 x 1.5 or ½ NPT	Transparent	-	-40 ... +80 °C



Cable entry	For cable Ø	Thread size	Colour	Ingress protection (max.)	Min./max. ambient temperature
Plastic cable gland	6 ... 10 mm	M20 x 1.5	Black or grey	IP66	-40 ... +80 °C
Plastic cable gland, Ex e	6 ... 10 mm	M20 x 1.5	Light blue	IP66	-20 ... +80 °C (standard) -40 ... +70 °C (option)
Plastic cable gland, Ex e	6 ... 10 mm	M20 x 1.5	Black	IP66	-20 ... +80 °C (standard) -40 ... +70 °C (option)
Brass cable gland, nickel-plated	6 ... 12 mm	M20 x 1.5	Blank	IP66	-60 ¹⁾ / -40 ... +80 °C
Brass cable gland, nickel-plated, Ex e	6 ... 12 mm	M20 x 1.5	Blank	IP66	-60 ¹⁾ / -40 ... +80 °C
Stainless steel cable gland	7 ... 12 mm	M20 x 1.5	Blank	IP66	-60 ¹⁾ / -40 ... +80 °C
Stainless steel cable gland, Ex e	7 ... 12 mm	M20 x 1.5	Blank	IP66	-60 ¹⁾ / -40 ... +80 °C
Plain threaded	-	M20 x 1.5	-	IP00	-
Junction box, M12 x 1 (4-pin)	-	M20 x 1.5	-	IP65	-40 ... +80 °C
Plug screw	-	M20 x 1.5	Blank	IP66	-60 ... +80 °C
Sealing plugs for transport	-	M20 x 1.5	Transparent	-	-40 ... +80 °C

1) Special version on request (only available without explosion protection or with specific approvals). other temperatures on request

Number and position of cable inlets / cable glands after consultation

Transmitter



Output signal 4 ... 20 mA, HART® protocol, FOUNDATION™ Fieldbus and PROFIBUS® PA				
Transmitter (selectable versions)	Model T15 (for RTD)	Model T16 (for TC)	Model T32	Model T53
Data sheet	TE 15.01	TE 16.01	TE 32.04	TE 53.01
Output				
■ 4 ... 20 mA	x	x	x	
■ HART® protocol			x	
■ FOUNDATION™ Fieldbus and PROFIBUS® PA				x
Explosion protection	Optional	Optional	Optional	Standard

For detailed specifications see respective transmitter data sheet

Mounting of two or more transmitters only possible without explosion protection.

Fitting of third-party products possible.

Mounting position, number of transmitters and their fixing method on request.

Functional safety (option) with temperature transmitter model T32



In safety-critical applications, the entire measuring chain must be taken into consideration in terms of the safety parameters. The SIL classification allows the assessment of the risk reduction achieved by the safety installations.

Selected TIF11 field cases, in combination with a suitable temperature transmitter (e.g. model T32.1S, TÜV certified SIL version for protection systems developed in accordance with IEC 61508), are suitable as sensors for safety functions to SIL 2.

Operating conditions

Ambient and storage temperature



-60 ¹⁾ / -40 ... +80 °C

1) Special version on request (only available with specific approvals)





Other ambient and storage temperatures on request

Accessories



■ Models T15 and T16

Model	Description	Order number
Programming unit Model PU-548 	<ul style="list-style-type: none"> ■ Easy to use ■ LED status display ■ Compact design ■ No further voltage supply needed, neither for the programming unit nor for the transmitter ■ Incl. 1 model magWIK magnetic quick connector 	14231581
Magnetic quick connector magWIK 	<ul style="list-style-type: none"> ■ Replacement for crocodile clips and HART® terminals ■ Fast, safe and tight electrical connection ■ For all configuration and calibration processes 	14026893

■ Model T32.xS

Model	Description	Order number
Programming unit, model PU-H		
VIATOR® HART® USB 	HART® modem for USB interface	11025166
VIATOR® HART® USB PowerXpress™ 	HART® modem for USB interface	14133234
VIATOR® HART® RS-232 	HART® modem for RS-232 interface	7957522
VIATOR® HART® Bluetooth® Ex 	HART® modem for Bluetooth interface, Ex	11364254
Magnetic quick connector magWIK 	<ul style="list-style-type: none"> ■ Replacement for crocodile clips and HART® terminals ■ Fast, safe and tight electrical connection ■ For all configuration and calibration processes 	14026893

■ Common accessories

Model	Description	Order number
Adapter 	<ul style="list-style-type: none"> ■ Suitable for TS 35 per DIN EN 60715 (DIN EN 50022) or TS 32 per DIN EN 50035 for mounting on a DIN rail ■ Material: Plastic / stainless steel ■ Dimensions: 60 x 20 x 41.6 mm 	3593789
Adapter 	<ul style="list-style-type: none"> ■ Suitable for TS 35 per DIN EN 60715 (DIN EN 50022) for mounting on a DIN rail (2 adapters required per transmitter) ■ Material: Steel, tin-plated ■ Dimensions: 49 x 8 x 14 mm 	3619851

Configuration software

■ WIKAsoft-TT (for T15 and T16)

■ WIK_A_T32

Manufacturer's information and certificates

Logo	Description
-	China RoHS directive

Certificates

- 2.2 test report
- 3.1 inspection certificate
- DKD/DAkkS calibration certificate

Approvals and certificates, see website

Ordering information

Model / Explosion protection / Case material / Transmitter / Cable bushings / Threaded connection for cable bushing / Certificates / Options

© 01/2018 WIKA Alexander Wiegand SE & Co. KG, all rights reserved.
The specifications given in this document represent the state of engineering at the time of publishing.
We reserve the right to make modifications to the specifications and materials.

