

Compact temperature switch Ex protection Ex-d, IP 65 Model TCA



WIKA data sheet TV 31.65



Applications

- Temperature monitoring and direct switching of electrical loads
- Control and regulation of industrial processes
- Universally suitable for machine building, plant, vessel, apparatus construction and food industry, chemical industry, petrochemical industry
- For measuring points with limited space
- Ignition protection type GAS Ex-d Dust Ex-tD Gr. II Cat. 2 GD

Special features

- Case aluminium, epoxy resin coated
- Ingress protection IP 65, NEMA 4
- Ambient temperature -40 ... +85 °C
- 1 switch point, SPDT or DPDT with a high contact rating of up to 15 A/AC 220 V
- Capillary up to 10 m



Fig. left: Temperature switch model TCA-C
Fig. right: Temperature switch model TCA-B

Description

These high-quality and robust temperature switches have been developed especially for safety-critical applications. The high quality and the manufacturing of the product ensures reliable monitoring of your plant. The manufacturer, Cella, is certified to ISO 9001. In production, the switch is monitored, step by step, through quality control software, and is subsequently 100 % tested.

All wetted parts materials are from stainless steel. Each switch family is available in IP 65, Ex-ia or Ex-d versions.

In order to ensure as flexible operation as possible, the temperature switches are fitted with micro switches, which enable the switching of an electrical load of up to 15 A/ AC 220 V directly. For smaller contact ratings, such as for PLC applications, Argon gas-filled micro switches with gold-plated contacts can be selected as an option.

With its flexible AISI 316 spiral protection hose, the model TCA temperature switch is extremely robust and guarantees optimal operating characteristics for applications requiring particularly high corrosion protection.

Standard version

Case

Aluminium, epoxy resin coated, case cover with screw-type cover, due to anti-twist device secured against unauthorised intervention

Ingress protection

IP 65 per EN 60529 / IEC 529

Permissible ambient temperature

-40 ... +85 °C

Connection to thermowell

Stainless steel, connection thread ½ NPT

Sensor

AISI 316

Diameter: 9.5 mm

Length: see table "Sensor length X and immersion depth Y"

Measuring system

Gas actuated temperature system

dependent on the temperature range, SAMA class II C or class II A

Capillary length

Length	Code
Direct assembly	B
2 m	C
5 m	Q 1)
10 m	R 1)

1) Capillaries to SAMA II A: The maximum permitted height difference between sensor and housing is 2 m.

Immersion depth

The maximum immersion depth Y (see dimensional drawing) can be calculated as per the following equation:

Capillary length in metre x 145 mm

Example:

Capillary length 2 m

=> 2 x 145 mm = 290 mm = max. immersion depth

The length K is reduced accordingly.

Switch contacts

Code	Type	Design	Electrical rating (resistive load) 2)	
			AC	DC
1	SPDT	Silver contacts	<u>15 A, 220 V</u>	2 A, 24 V 0.5 A, 125 V 0.25 A, 220 V
2 3)	DPDT	Silver contacts	<u>5 A, 220 V</u>	0.5 A, 24 V
3	SPDT	Silver contacts inert gas filled T _{amb} : -30 ... +70 °C	<u>15 A, 220 V</u>	2 A, 24 V 0.5 A, 220 V
4 3)	DPDT	Silver contacts hermetically sealed in air	<u>5 A, 220 V</u>	0.5 A, 24 V
5	SPDT	Gold-plated contacts inert gas filled T _{amb} : -30 ... +70 °C	<u>1 A, 125 V</u>	0.5 A, 24 V

2) Only the underlined data are shown on the product label

3) Simultaneous triggering within 2 % of the full temperature range

Repeatability

≤ 1 % of the full temperature range

Setting ranges, max. test temperature, max. switch hysteresis

Setting range	Working range	Test temperature	Max. switch hysteresis			
			Contact code 1, 3, 5	Contact code 2	Contact code 4	SAMA class
-30 ... +10 °C	-40 ... +60 °C	+90 °C	2 °C	2 °C	8 °C	II C
-15 ... +40 °C	-40 ... +60 °C	+90 °C	1.5 °C	2 °C	8 °C	II C
10 ... 70 °C	-40 ... +70 °C	+90 °C	1.5 °C	2 °C	8 °C	II C
40 ... 100 °C	-40 ... +120 °C	+140 °C	1.5 °C	2 °C	8 °C	II C
70 ... 120 °C 4)	-40 ... +170 °C	+180 °C	1.5 °C	4 °C	16 °C	II A
90 ... 160 °C	-40 ... +170 °C	+180 °C	2 °C	4 °C	16 °C	II A
130 ... 190 °C	-40 ... +190 °C	+210 °C	2.5 °C	4 °C	16 °C	II A
160 ... 250 °C	-40 ... +280 °C	+300 °C	2.5 °C	4 °C	16 °C	II A

4) Ambient temperature max. +70 °C

Switch points

After unscrewing the case cover, **switch point adjustment** can be made using the adjustment screw. The switch point is settable within the entire measuring range with the **following rules**:

- Define the value $A = 2 \times \text{repeatability} + \text{switch hysteresis}$
- If the temperature is rising, the switch point should be set between (min. + value A) up to max. of the setting range
- If the temperature is falling, the switch point should be set between min. up to (max. - value A) of the setting range

Example:

Setting range: 40 ... 100 °C with one switch contact

Repeatability: 1 % of 100 °C = 1 °C

Switch hysteresis = 1.5 °C (see table setting ranges)

Value $A = 2 \times 1 \text{ °C} + 1.5 \text{ °C} = 3.5 \text{ °C}$

If the temperature is rising, the switch point should be set between 43.5 °C and 100 °C.

If the temperature is falling, the switch point should be set between 40 °C and 96.5 °C ($96.5 \text{ °C} = 100 \text{ °C} - 3.5 \text{ °C}$).

For optimal performance we suggest the switch point lies between 25 % and 75 % of the setting range.

Electrical connection

½ NPT female, cable connection using internal terminal block, protective conductor connection using internal and external screw, max. earth cable cross-section 4 mm²

Temperature switch certified per:

Low voltage directive 73/23 EEC and 93/68 EEC

Dielectric strength

Safety class I (EN 61298-2: 1997-06)

Mounting

Direct or wall mounting

The preferred connection location of the temperature switch should be below. Alternatively the instrument can be installed so that internal access is from the front of the enclosure and the electrical connection is located on the side.

Weight

approx. 1 kg

Options

- Other connection to thermowell
- Electrical connection ¼ NPT, G ½ or M20 x 1.5 (female)
- Cable gland on request
- Switch point adjustment to customer specification
- 2" pipe mounting set
- Case made of AISI 316
- Helical bulb for measuring ranges -15 ... +40 °C and +10 ... +70 °C
- Version for offshore ⁵⁾, geothermal ⁵⁾ or tropicalised application ⁵⁾
- Version for applications to NACE ⁵⁾
- Version for ammonia applications ⁵⁾
- Accessories:
Thermowells

Approvals and certificates

- SIL-2 version ⁶⁾
- GOST-R certificate
- Test certificate *CA* (confirmation of the switching accuracy)
- Test report *CP* (3-time listing of the switch point, requires switch point specification)
- Material certificate 3.1 per EN 10204

⁵⁾ Contacts code 3, 4, or 5 required

⁶⁾ Contacts code 3 or 5 required

Dimensions in mm

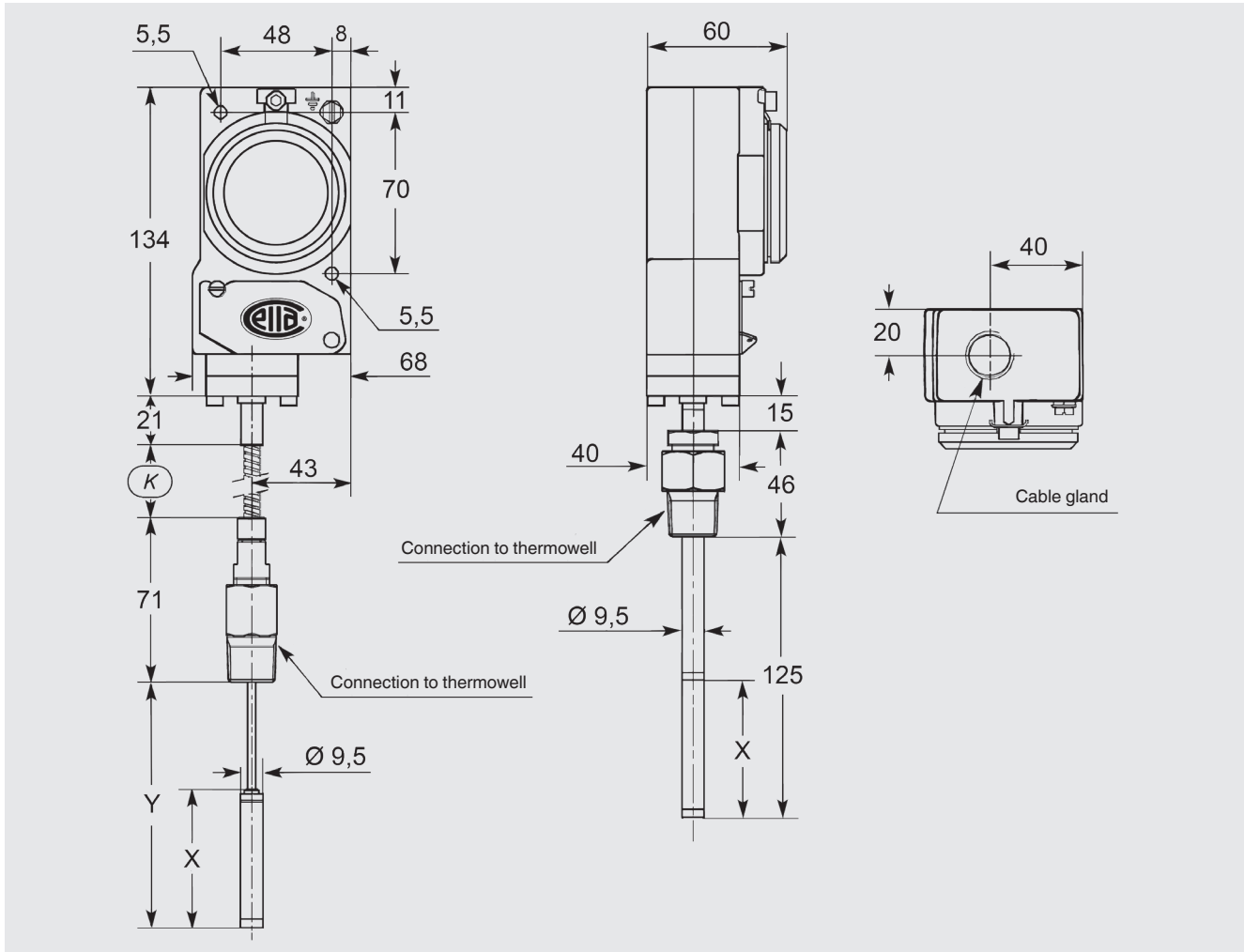

Sensor length X and immersion depth Y

Capillary length	Code	Dimensions in mm SAMA II C			SAMA II A		
		X	Y	Y _{max}	X	Y	Y _{max}
Direct assembly	B	65	125	125	55	125	125
2 m	C	71	100	350	55	100	350
5 m	Q ⁷⁾	84	130	900	55	100	900
10 m	R ⁷⁾	124	170	1800	55	100	1800

⁷⁾ Capillaries to SAMA II A: The maximum permissible height difference between sensor and housing is 2 m.

Ordering information

Model / Capillary length / Switch contacts / Setting range / Connection to thermowell / Electrical connection / Switch point(s) / Switch direction(s) / Options

Example: TCA - B3 - 40/100 °C - 1/2" NPT-M - 1/2 NPT-F

© 2012 WIKA Alexander Wiegand SE & Co. KG, all rights reserved.
The specifications given in this document represent the state of engineering at the time of publishing.
We reserve the right to make modifications to the specifications and materials.



WIKAI Alexander Wiegand SE & Co. KG
Alexander-Wiegand-Straße 30
63911 Klingenberg/Germany
Tel. (+49) 9372/132-0
Fax (+49) 9372/132-406
E-mail info@wika.de
www.wika.de