

PRODUCT

The **Hoppe Electronic Inclinometer** is capable of measuring the actual heel angle and determining the amplitude of the rolling oscillation of the ship over a range of $\pm 90^\circ$. Furthermore it is capable of measuring the time between the maximum values of the rolling oscillation and determining the roll period over a specific range. It provides all data with sufficient accuracy for a proper assessment of the ship's dynamic situation.

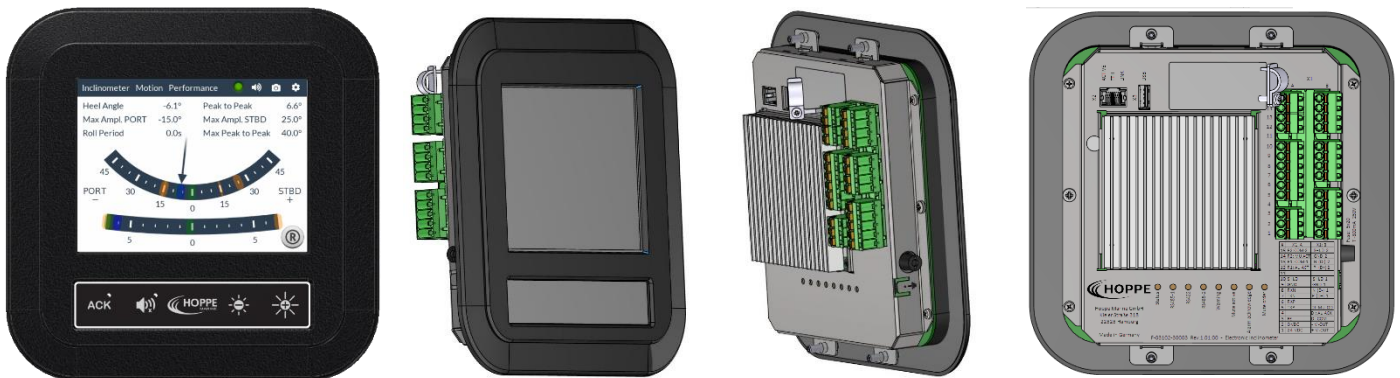

TECHNICAL FEATURES

- Supporting the decision-making process on board in order to avoid dangerous situations.
- Assisting in and facilitating maritime casualty investigations by providing information about the roll period and the heel angle of the ship.
- Determination of actual heel and pitch angle of the ship.
- Determination of roll amplitude, as well as roll and pitch period of the ship.
- Presentation of all relevant information on a single display.
- Indication of active warnings.
- Peak value reset function.
- Alarm management in accordance with IEC 61924-2.
- Observation of safety relevant parameters.
- Interfaces to VDR (Heel/Roll-Measurement via NMEA telegram \$--HRM).
- Open RS485 with motion data to automation.
- Display Dimming Control (DDC) via NMEA telegrams.

SIGNALS

- | | |
|---|-----------------------|
| • Actual heel angle, list angle, pitch angle and trim angle | • Peak to peak angle |
| • Max. amplitude PORT | • Max. amplitude STBD |
| • Roll period and pitch period | • Max. peak to peak |
| • GM est. | • Period ratio |
| • Roll acceleration | • Comfort level |

MEASUREMENT SPECIFICATIONS

PARAMETER	RANGE	TYPICAL ACCURACY
Roll angle	$\pm 90^\circ$	$0.11^\circ \text{ RMS}_{2\sigma}^{1)}$ or 5% of reading (whichever is greater)
Pitch angle	$\pm 45^\circ$	$0.11^\circ \text{ RMS}_{2\sigma}^{1)}$ or 5% of reading (whichever is greater)
List/Trim angle (5 min. average)	$\pm 45^\circ/\pm 90^\circ$	$0.09^\circ \text{ RMS}_{2\sigma}^{1)}$ or 5% of reading (whichever is greater)
Roll period	4 – 40 sec.	0.1 sec. $\text{RMS}_{2\sigma}$
Pitch period	4 – 40 sec.	0.1 sec. $\text{RMS}_{2\sigma}$
Angular acceleration	$\pm 50^\circ/\text{sec.}^2$	$1^\circ/\text{sec.}^2 \text{ RMS}_{2\sigma}^{1)}$

^{2σ)} Approx. 95 % of all measurement results will be in between the bound.

¹⁾ When subjected to two hours of continuous inharmonic wave motion in severe weather conditions with max. 10° amplitude with the device mounted 9m away from the roll center at reference conditions according to DIN 43751-1:1987, $T_{\text{ref.}} = +20^\circ\text{C}$.

MEASUREMENT CONDITIONS

Operating temperature	-15°C to $+70^\circ\text{C}$
Storage temperature	-20°C to $+85^\circ\text{C}$
Reference temperature	$+20^\circ\text{C}$
Linear temperature influence (angles)	$\pm 0.02^\circ/\text{C}$
Temperature hysteresis (angles)	0.15° over full operating temperature range
Relative humidity (when housing open)	10 % to 85 %, not condensing

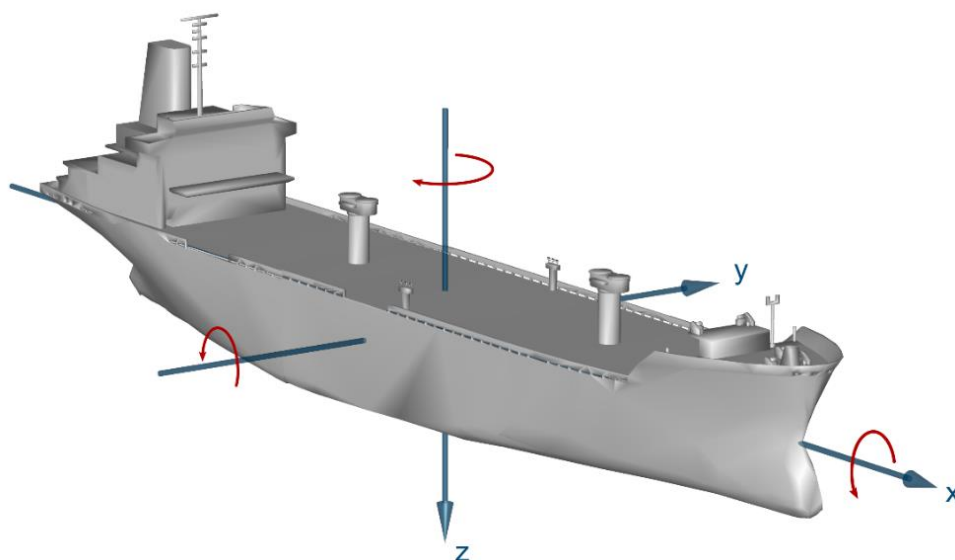
ORIENTATION

ELECTRICAL SPECIFICATIONS

Interface types & transfer rates	1x RS 422 (Baud 4800, no parity, 8 data bits, 1 stop bit) 2x RS 485 (Baud 4800/38400, no parity, 8 data bits, 1 stop bit) 1x Ethernet 100 Mbit, Auto-MDIX 1x Universal Serial Bus (USB, max. 50mA)
Protocol	NMEA, HTTP, UDP (optional)
Power supply (S-Line or UPS)	24 VDC (+30% / -25% = 18 V – 31.2 V), max. 36 VDC input voltage 48 VDC with Power over Ethernet (IEEE 802.3) 800 mA miniature fuse, time-lag, 5x20 mm
Digital Inputs	DI-#1 Warning acknowledged, DI-#2 Mute order max. 24 VDC, ON-voltage 12V, OFF-voltage 8V;
Relay Outputs	K-1 Warning active, K-2 Mute active potential-free contacts max. 1A at max. 30VDC or max. 0.3A at max. 125 VAC
Power consumption	12 W

PIN #	X1: A	
15	COM-2	MUTE
14	K-2	ACTIVE
13	COM-1	WARNING
12	K-1	ACTIVE
11		
10	SHLD	RS422
9	SGND	
8	RXN	
7	TXN	
6	RXP	
5	TXP	
4		
3	FE	POWER IN (12 W)
2	0 VDC	
1	24 VDC	

PIN #	X1: B	
15	SHLD	RS485-2
14	SGND	
13	N (D-)	
12	P (D+)	
11		
10	SHLD	RS485-1
9	SGND	
8	N (D-)	
7	P (D+)	
6		
5	DI-#2	MUTE ORDER
4	DI-#1	WARNING ACKN.
3	DI-0V	DIG. INPUTS COM
2	-V-OUT	24 VDC for
1	+V-OUT	DI (max. 40 mA)

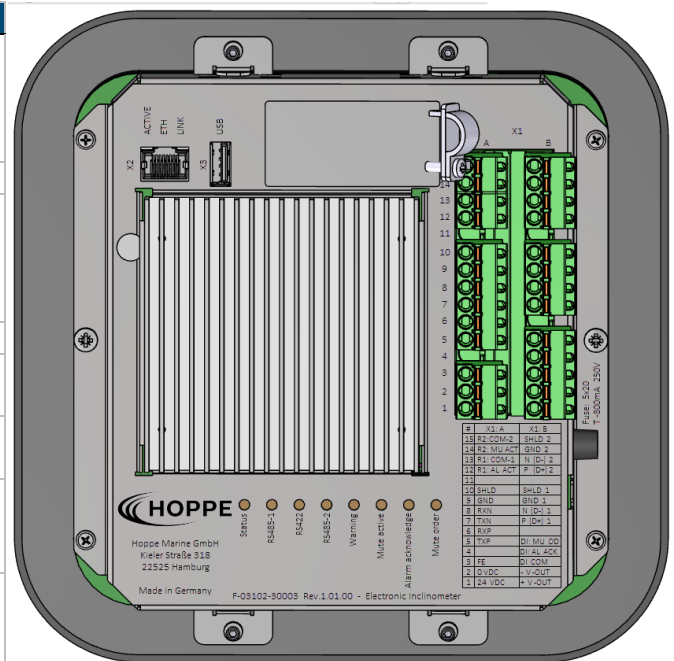

COMMUNICATIONS

BAMS Serial Data Interface (RS 422)	IEC 61162, IEC 61924-2 4800 Baud Output sentences: \$--ALC; \$--ALF Input sentences: \$--HBT; \$--ACN; \$--TXT
VDR Serial Data Interface (RS 485-1)	IEC 61162-1,-2 Output sentences: \$--HRM; 38400 Baud
Global Dimming Interface (RS 485-2)	IEC 61162-1 Input/Output sentences: \$--DDC; 4800 Baud
Alert State Transition Diagram	acc. IEC 61924-2

GENERAL SPECIFICATIONS

Cutout-Dimensions & Weight	159x159 mm; 65 mm minimum space behind cutout, 0.85 kg
Computer data	Processor: ARM Cortex A9 Dual Core, 800 MHz, 32 bit; 1GB RAM; Root file system: FLASH 4 GB;
Protection class	IP44, for bridge installation (protected area);
Rules & Regulations	General Performance Standard ISO 19697:2014; Performance Standards Resolution MSC.191(79); Performance Standards Resolution MSC 363(92); IEC 61162:2010; IEC 60945:2002; BSH Display Standard; Bridge Alert Management; Alert State Diagram; NMEA Sentences Requirements

DIMENSIONS

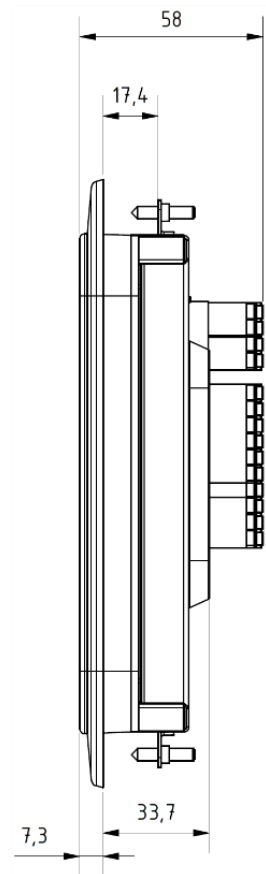
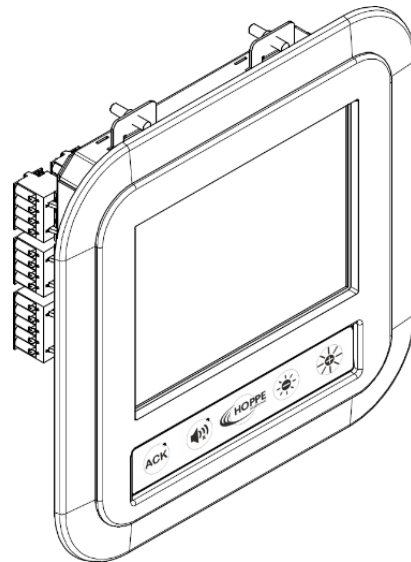
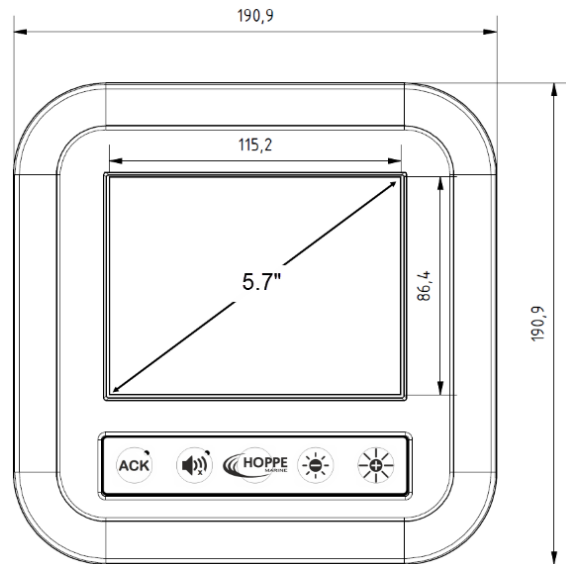

CERTIFIED PRODUCT

