

# ELECTRIC VALVE ACTUATOR TYPE CAR

FOR 2 & 3-WAY VALVES TYPE G/L/M/S 2FM-T & G/L/M/S 3FM-T

O-4.11.08-J

Page 1 of 4



## APPLICATIONS

Electric valve actuator type CAR is specially designed to meet the demands of the powerful low frequency vibration environments in marine installations.

The main applications are cooling of fresh water, sea water and lubricating oil systems for main and auxiliary engines. The actuator is used for Clorius 2 or 3-way valves type L3FM-T, M3FM-T, G3FM-T and S3FM-T.

## MOUNTING

For mounting and starting up, the instructions delivered with the actuator must be followed carefully.

## SERVICE

No special service is needed. It is recommended to check and grease the actuator at every docking or every three years.

## TECHNICAL DATA

<b>Casing:</b>	Watertight IP67, Nema 4 and 6
<b>Ambient temp.:</b>	-30°C to +70°C, 150°C/1 hr.
<b>Power Supply:</b>	120/230 VAC, 1-Phase (50Hz/60Hz), 380/400/440 VAC, 3-Phase (50Hz/60Hz) 24 VDC (CAR 015-028)
<b>Torque switches:</b>	Open/Close
<b>Limit switches:</b>	Open/Close, additional limit switches on request
<b>Stall protection:</b>	Built-in Thermal Protection Cut-off at 150°C ± 5°C / Reset at 97°C ± 15°C
<b>Travel angle:</b>	90° ± 5°
<b>Indicator:</b>	Continuous Position Indicator
<b>Manual override:</b>	AUTO Declutching Mechanism
<b>Worm gear:</b>	Permanently lubricated and Self-locking
<b>Mechanical stops:</b>	External Adjustable Limit Stops
<b>Space heater:</b>	20 W (115/230 VAC, 24 VDC) Anti-Condensation
<b>Cabeling:</b>	2 x R 3/4"
<b>Lubrication:</b>	Grease NLGI Grade 2 (EP-Type)
<b>Materials:</b>	Steel, Aluminium Alloy, Al Bronze
<b>External coating:</b>	Anodizing and Dry Powder Epoxy
<b>Duty Cycle:</b>	Please see specification

## FEATURES

- Robust design
- Maintenance free
- Reliable even in rough environments
- Easy installation
- User friendly

## SPECIFICATIONS

Type	Max. torque Nm	Operating time sek/90° (50/60 Hz)	Weight kg	No. of handle turns	Current draw max. A (1-phase 120V)	Current draw max. A (1-phase 230V)	Current draw max. A (3-ph 400V)	Current draw max. A (24 VOC)	Duty cycle S4(%)
CAR 009	90	17/14	11	8.5	1.2	0.6	0.18	2.2	50
CAR 019	186	17/20	13	10	1.5	0.7	0.28		50
CAR 028	274	24/20	17	12.5	2	0.7	0.3	7	50
CAR 060	588	29/24	22	14.5	3.1	1.18	0.5		25
CAR 100	981	29/24	25	14.5	4.5	2	0.87		25
CAR 150	1471	87/72	68	43.5	3.1	1.18	0.5		25
CAR 200	1962	87/72	70	43.5	4.5	1.8	0.8		25

Subject to change without notice

SEP 2020

[www.cloriuscontrols.com](http://www.cloriuscontrols.com)

**DIMENSION SKETCH**

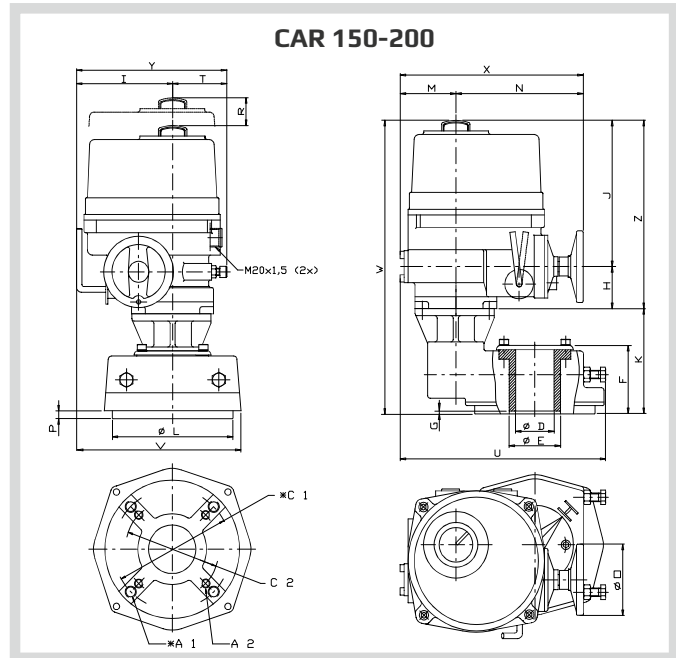
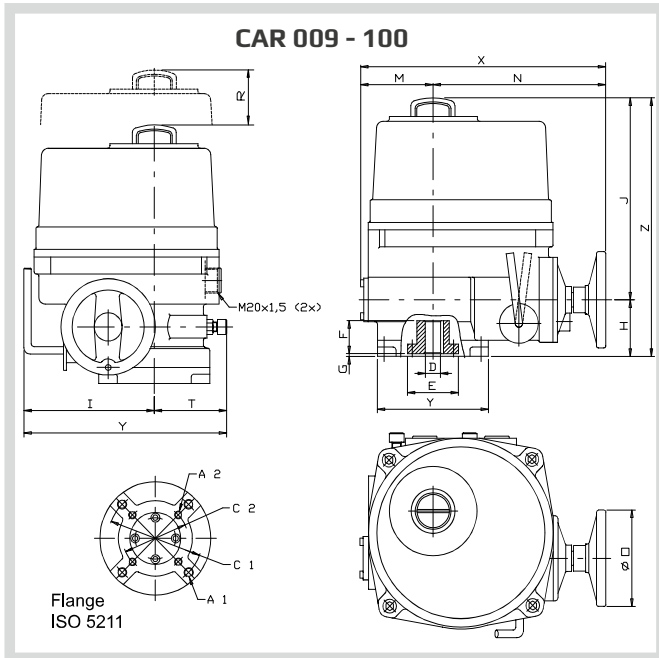

3

Type	CAR 009	CAR 019	CAR 028	CAR 060	CAR 100	CAR 150	CAR 200
Flange	F07	F07, F10	F12, F10	F14, F12		F16, F14*	
C1		102	125	140		165	
C2	82	70	102	125		140*	
A1		M10	M12	M16		M14*/M16*	
A2	M8	M8	M10	M12		M20	
B	12	15	18	22		30	
<b>D(Max**)</b>	<b>22</b>	<b>22</b>	<b>32</b>	<b>42</b>		<b>75</b>	
E	55	57	75	85		100	
F	43	43	52	59		126	
G	2	2	2	2		7	
H	60	60	70	78		78	
I	113	139	159	191		191	
J	213	213	250	283		283	
K						195	
L	102	120	145	175		266	
M	56	77	83	99		99	
N	175	184	202	226		226	
O	102	102	125	170		170	
P						16	
R	108	108	130	178		178	
T	68	85	99	116		116	
U						388	
V						318	
W						556	
X	231	261	285	325		325	
Y	181	224	258	307		307	
Z	273	273	320	361		361	

\* For optional alternative flanges

\*\* Maximum dimension including keyway

# ELECTRIC VALVE ACTUATOR TYPE CAR

For 2 & 3-way valves type G/L/M/S 2FM-T & G/L/M/S 3FM-T

0-4.11.08-J

## ACCESSORIES

### CAR PROPORTIONAL CONTROL UNIT PCU PB90

CAR 009-200

<b>Command signal input</b>	4-20 mA, nominal input impedance 150 Ohm, jumpers I1 and I2 0-10 V, nominal input impedance 260k Ohm, jumper V1
<b>Analogue feedback signal</b>	4-20 mA, self powered, can drive up to 300 Ohm
<b>Fuse</b>	3,15 AT 5x20 mm, mounted on the PB90 card
<b>Resolution</b>	Approx. 0,3%
<b>Conversion</b>	12 bit maximum. Normal range (4-20 mA) = 1/3200
Position board. Characteristic of feedback element and actuator system response affect the true performance.	

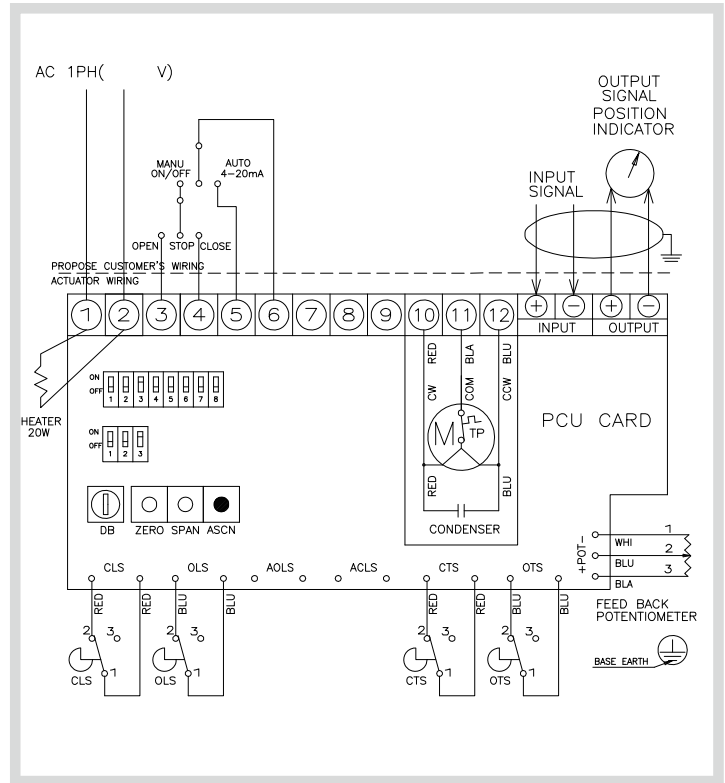

- CLS: Close Limit Switch (250VAC 15A)
- OLS: Open Limit Switch (250VAC 15A)
- CTS: Close Torque Switch (250VAC 15A)
- OTS: Open Torque Switch (250VAC 15A)
- TP: Thermal Protector (250VAC 15A)

CAR 009-200

### CAR CURRENT POSITION TRANSMITTER CPT

- For continuous, analogue feed back signal 4-20 mA
- R/I Transmitter
- The electronic components are protected against dirt and similar

- CLS: Close Limit Switch (250VAC 6A)
- OLS: Open Limit Switch (250VAC 6A)
- CTS: Close Torque Switch (250VAC 6A)
- OTS: Open Torque Switch (250VAC 6A)
- TP: Thermal Protector (250VAC 15A)

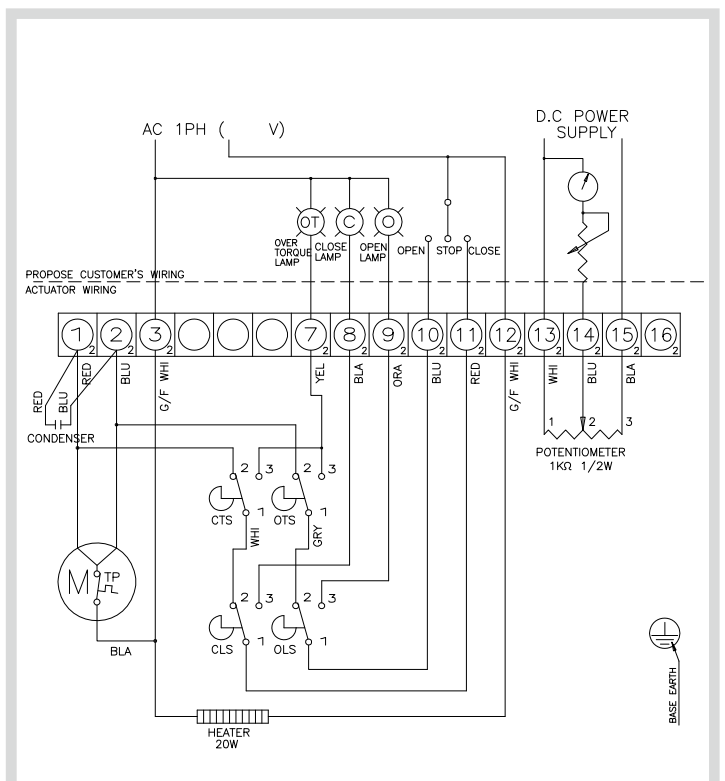

## ACCESSORIES

### CAR POTENTIOMETER PIU

- For CAR 009 - CAR 250
- For continuous position feedback from 0° to 90°
- The whole unit is built into the actuator
- Potentiometer 1k Ohm, senses the actuator position during the whole turning movement
- Mounting details included
- Resistance 1k Ohm
- Resistance tolerance ±20%
- Linearity ±1%
- Max load 1W at +70 °C

- CLS: Close Limit Switch (250VAC 15A)  
 OLS: Open Limit Switch (250VAC 15A)  
 CTS: Close Torque Switch (250VAC 15A)  
 OTS: Open Torque Switch (250VAC 15A)  
 ACLS: Aux. Close Limit Switch (250VAC 15A)  
 AOLS: Aux. Open Limit Switch (250VAC 15A)  
 TP: Thermal Protector (250VAC 15A)

CAR 009-200

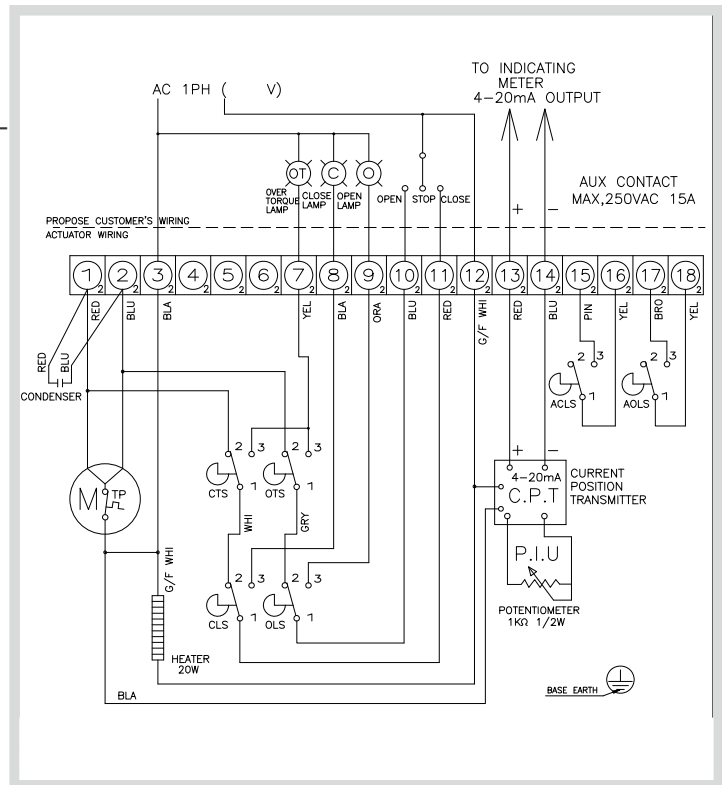

3

### RECOMMENDED ACTUATOR TYPES FOR G2/G3FM-TR and G2/G3FM-TL VALVES

Valve size	Actuator type CAR			
	P1≤5bar	P1≤10bar	P1≤16bar	P1≤25bar
DN 65	009	009	009	009
DN 80	009	009	009	009
DN 100	009	009	019	019
DN 125	019	019	028	028
DN 150	019	028	028	-
DN 200	028	060	060	-
DN 250	060	060	060	-
DN 300	060	100	100	-
DN 350	100	200	-	-
DN 400	100	200	-	-
DN 450	200	200	-	-
DN 500	200	250	-	-
DN 550	200	250	-	-
DN 600	200	300	-	-
DN 800	-	-	-	-

### RECOMMENDED ACTUATOR TYPES FOR G3FM-TM VALVES

Valve size	Actuator type CAR			
	P1≤5bar	P1≤10bar	P1≤16bar	P1≤25bar
DN 65	009	009	009	009
DN 80	009	009	009	009
DN 100	009	019	019	019
DN 125	019	019	028	028
DN 150	019	028	028	-
DN 200	060	060	060	-
DN 250	060	060	100	-
DN 300	100	100	100	-
DN 350	100	200	-	-
DN 450	200	250	-	-