

Two-stroke combustion sensor TCS-01CA®

for application on two-stroke diesel engines

Two-stroke combustion sensor for continuous measurement of cylinder pressure on two-stroke diesel engines (24h per day / 365 days per year).

Characteristics

- Sensor designed for 2-stroke application
- Digital electronic with event storing
- Very good thermodynamic performance
- Marine classification

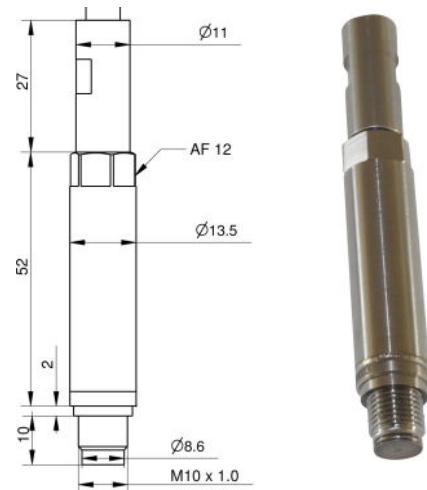

Application:

Permanent installation on two-stroke marine diesel engines for cylinder balancing and performance evaluation.

Technical Data

Measuring range pressure	0...300 bar
Over pressure static	400 bar
Frequency range	10 kHz
Thermal shock 1500 RPM pmi=9bar	< +/- 0,5 bar
Accuracy	≤ 1% Full scale
Temperature range of SCU	-40 °C ... 75 °C
Supply voltage	18...32 VDC @100 Ω load: min. 18.0 VDC @250 Ω load: min. 20.0 VDC @500 Ω load: min. 24.8 VDC
SCU current consumption	≤ 50 mA (continuous operation); 250 mA (switch-on peak)
Output signal range	4...20 mA
Electrical connector	MIL-C-26482
Thread	M10 x 1
Dimension sensor	36,5 mm , Ø 13,5 mm
Dimension electronic	38 mm x Ø 18 mm
Tightening torque	15 Nm
Weight incl. electronic	252 g

General specifications

Degree of protection	IP 67 (EN 60529)
CE approval	2004/1008/EG EN 60000-6-2 EN 60000-6-4 EN 60326-1
Marine qualification	
Bureau Veritas	2226/C1 BV
Class NK	TA20507M
Korean Register	HMB13238-AE001
Lloyd's Register	11-20041 (E1)-03
DNV	TAA00000H0
RINA	ELE193821XG

The robust type TCS-01CA[®] sensor for continuous measurement of cylinder pressures on two stroke diesel engines offers outstanding longevity and constant sensitivity.

Cylinder pressure measurements can be made with high precision because of its very good thermodynamic characteristics.

Mounting

For application on 2- stroke engines the sensor should be installed in a special adapter between cylinder cover and indicator cock.

The sensor is mounted on the flat pressure canal of the adapter with less pockets or less corners this significantly reduces the build-up of combustion deposit on at the sensor membrane.

The indicator valve should be opened regularly to blow out the combustion residuals.



TCS-01CA[®] mounted on an adapter before indicator cock



The closed face makes the sensor immune to soot ing.

Connector

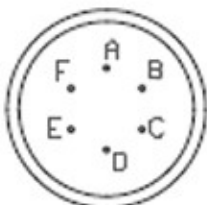

A = Power supply 18 - 32 V

B = Pressure signal output 4...20mA

D = Signal zero point / Power GND

C = Programming pin, only used for calibration

E, F not connected

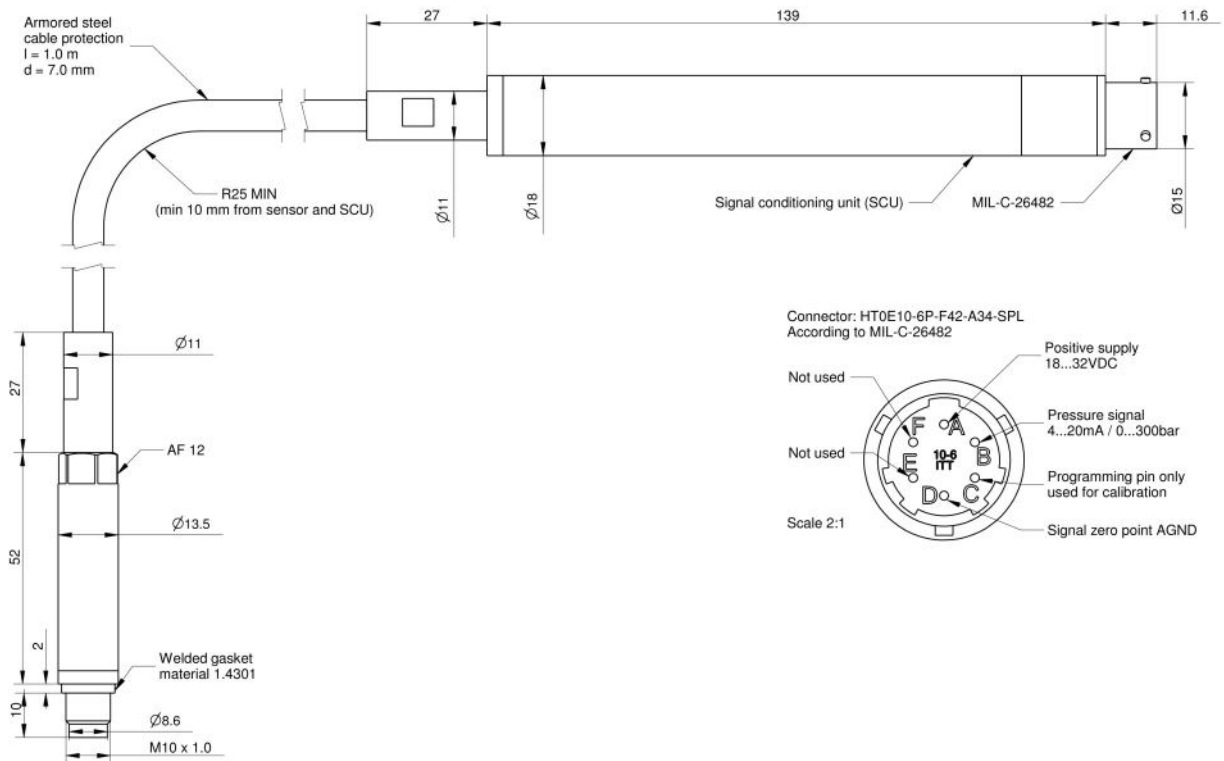

Product No.	Pressure range	Sensor length	Cable length	Static over-pressure
IW-6100	0 - 300 bar	52 mm	1,0 m	400 bar

Optional Accessories

- Adaptor for application on MAN B&W ME- and MC-C engines
- Adaptor for application on Wärtsilä RTA-/ Rtflex engines
- Connecting cable (5 m) incl. connector Hadimec KPTC
- Connecting cable (10 m) incl. connector Hadimec KPTC
- Connecting cable (20 m) incl. connector Hadimec KPTC
- Protection cover

Product No.

- IW-8015
- IW-8009
- IW-1132
- IW-1133
- IW-1130
- IW-6211