

Two-stroke combustion sensor TCS-01CA®-PMI

for application on PMI-auto-tuning-system

Two-stroke combustion sensor for continuous measurement of cylinder pressure on two-stroke diesel engines (24h per day / 365 days per year).

Characteristics

- Sensor designed for 2-stroke application
- Digital electronic with event storing
- Very good thermodynamic performance
- Marine classification
- Pin compatible to PMI-system

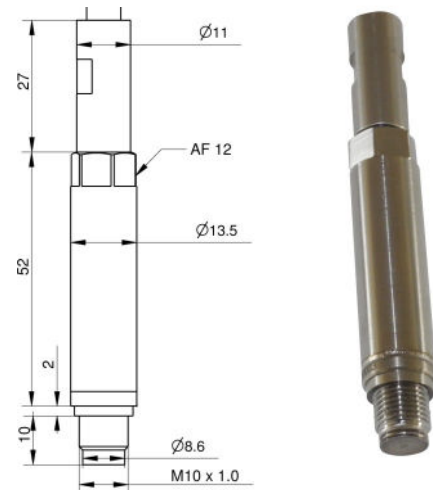

Application:

Permanent installation on two-stroke marine diesel engines for cylinder balancing and performance evaluation.

Technical data

Measuring range pressure	0...250 bar
Over pressure static	400 bar
Frequency range	10 kHz
Thermal shock 1500 RPM pmi=9bar	< +/- 0,5 bar
Accuracy	≤ 1% Full scale
Temperature range of SCU	-40 °C ... 75 °C
Supply voltage	18...32 VDC
SCU current consumption	≤ 50 mA (continuous operation); 250 mA (switch-on peak)
Output signal	4...20 mA
Sensitivity	61,4 µA / bar or 56 µA / bar
Electrical connector	Harting Han ES 10B (male) with housing Harting Han 24B (male)
Thread	M10 x 1
Dimension sensor	36.5 mm , Ø 13.5 mm
Tightening torque	15 Nm
Weight incl. electronic	1200 g

General specifications

Degree of protection	IP 67 (EN 60529)
CE approval	2004/1008/EG EN 61000-6-2 EN 61000-6-1 EN 61326-1
Marine qualification	
Bureau Veritas	2226/C1 BV
Class NK	TA20507M
Korean Register	HMB13238-AE001
Lloyd's Register	11-20041(E1)-03
DNV	TAA00000H0
RINA	ELE193821XG

The robust type TCS-01CA[®]-PMI sensor for continuous measurement of cylinder pressures on two stroke diesel engines offers outstanding longevity and constant sensitivity.

Cylinder pressure measurements can be made with high precision because of its very good thermodynamic characteristics.

Mounting

For application on 2- stroke engines the sensor should be installed in a special adapter between cylinder cover and indicator cock.

The indicator valve should be opened regularly to blow out the combustion residuals.



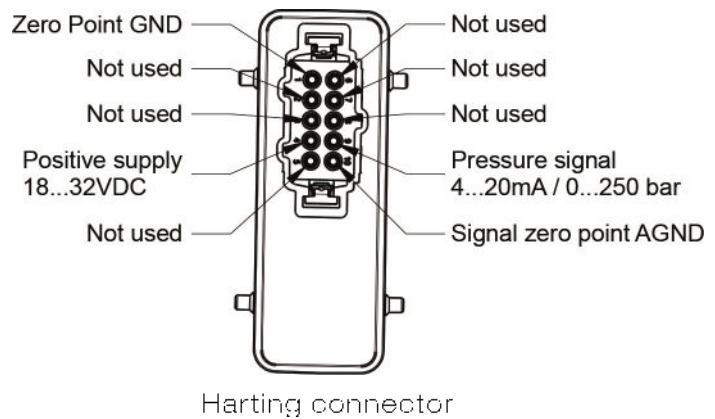
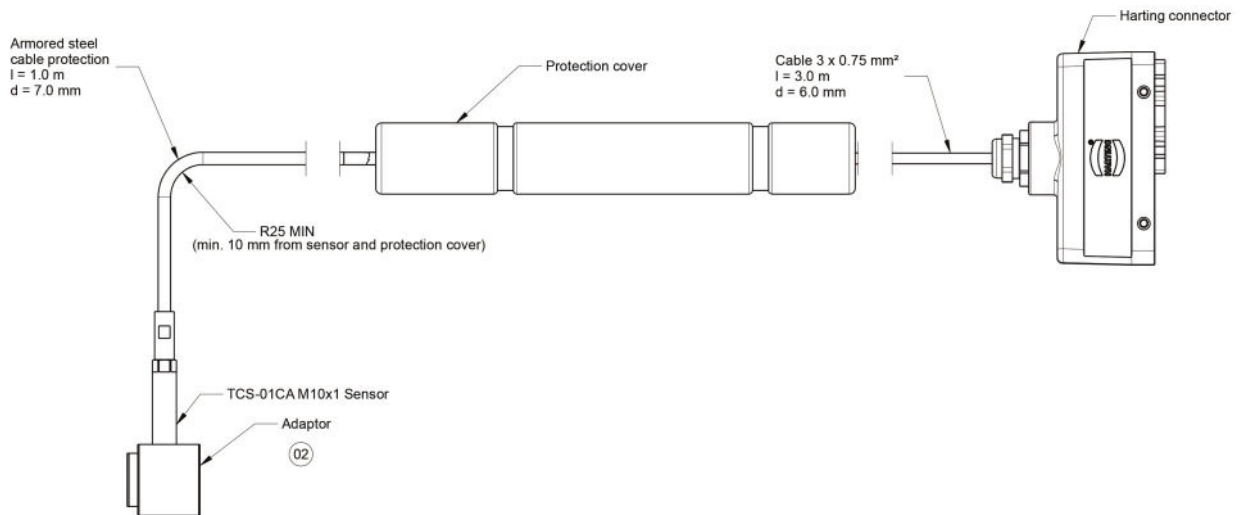

Product No.	Pressure range	Output signal	Total cable length	Static overpressure
IW-9100	0 - 250 bar	4 - 20 mA	4,0 m	400 bar
IW-9101	0 - 250 bar	4 - 20 mA	4,0 m	400 bar

Scope of supply

- TCS-01CA[®]-PMI sensor
incl. 4 m cable, protection cover, Harting connector and adaptor

Product No.

IW-9100

- TCS-01CA[®]-PMI sensor
incl. 4 m cable, protection cover, Harting connector and adaptor

IW-9101